

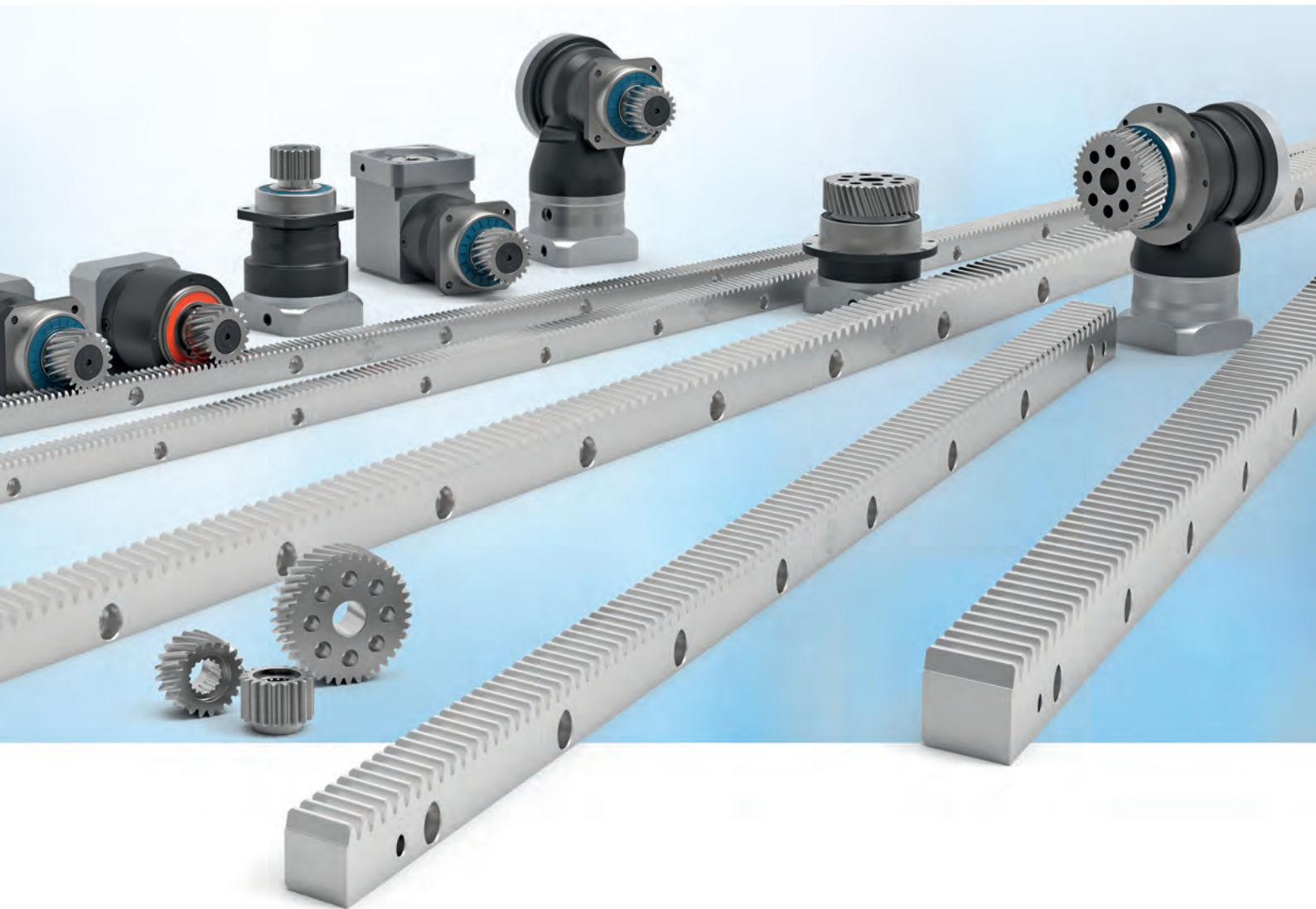

NEUGART RACK SYSTEM

Rack and pinion



Perfectly matched – for powerful
rack and pinion drives

The new integrated gearbox-pinion-rack combination:

A powerful complete solution for maximum precision and efficiency in your rack and pinion applications

Thanks to their precise gearing and high manufacturing quality, Neugart racks meet the highest requirements for feed force, smooth running, and positioning accuracy. The high-quality racks are optimally matched to our pinions and gearboxes and enable powerful and dynamic power transmission.

Precision racks for the highest demands

Neugart offers racks of the highest quality with straight or helical gearing. Our standard racks are made of induction-hardened tempered steel, cover a module range from 1.5 to 5 mm, and comply with quality level 6.

The racks are heat-treated and ground to optimize their mechanical properties. The standard versions are available in lengths of 1000 mm and 2000 mm. Customized lengths can also be produced on request.

Thanks to this flexibility, Neugart can provide the right rack for a wide variety of applications – precise, durable, and powerful.

With our extensive product portfolio of gearboxes, pre-assembled pinions, and matching racks, we offer you a perfectly coordinated system solution from a single source – for easy integration and maximum performance.

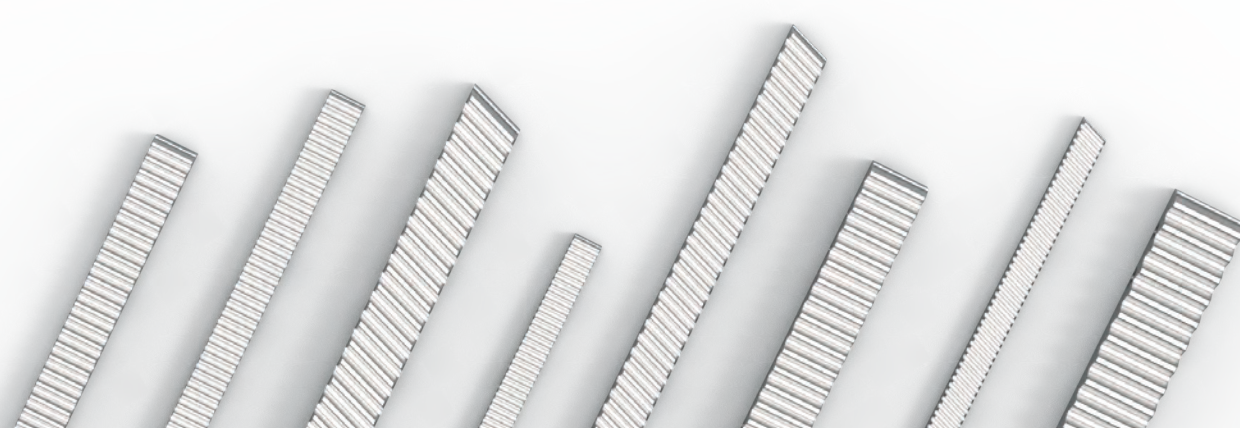

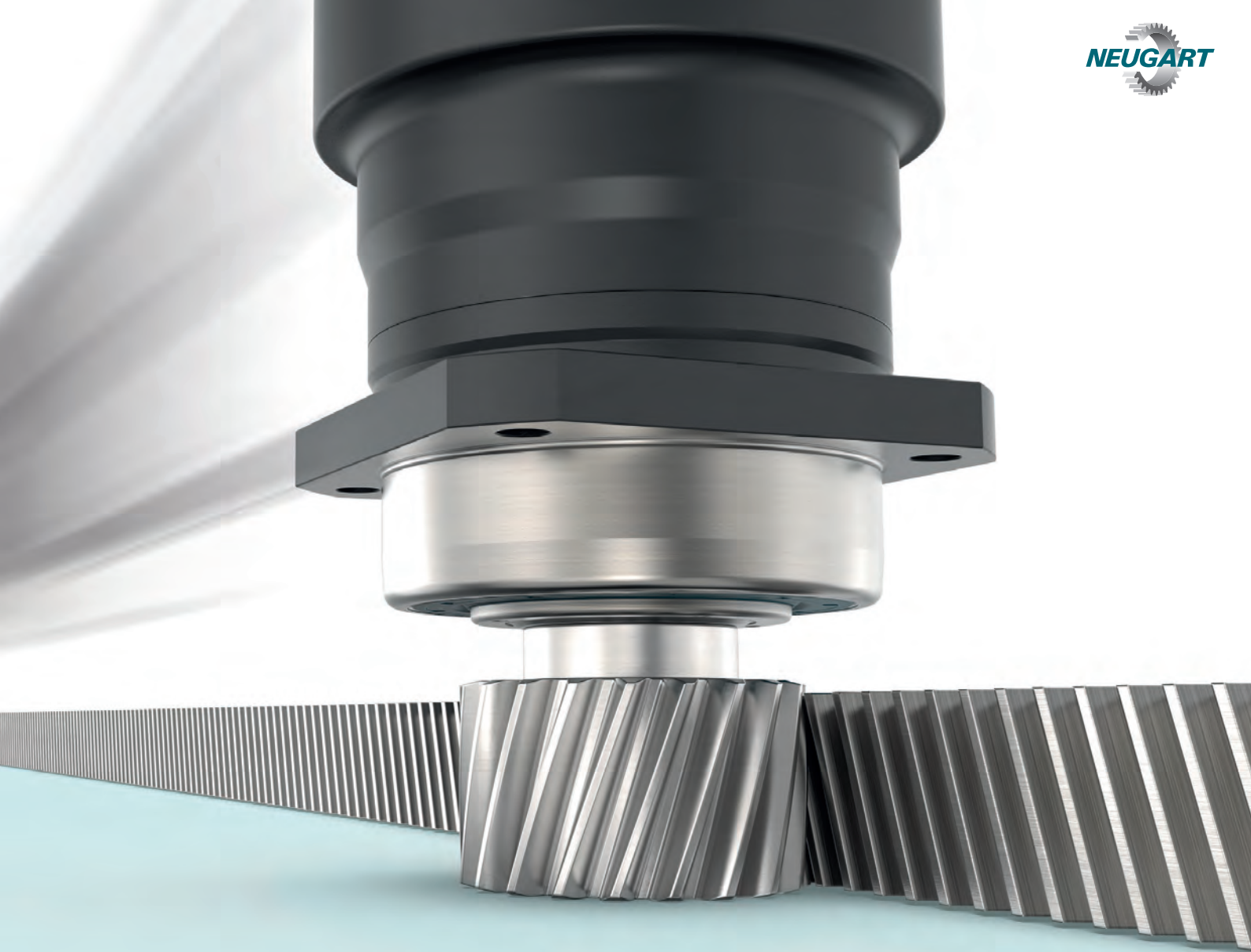

Rack and pinion drive in a portal milling machine – high feed force and precise positioning for heavy workpieces.



Rack and pinion gears in flatbed lasers – ideal for high cutting speeds and smooth operation.



Linear traverse axes for robot racks enable an extended working range with high load capacity.



Numerous combination options

Our pinions can be flexibly combined with a wide selection of gear series – from frame size 060 to 200. The right pinion is available for every gear, perfectly matched to the rack.

- Precision Line: Four gearbox types for maximum positioning accuracy.
 - Economy Line: Four robust and powerful standard gearboxes with an excellent price-performance ratio.
- Coaxial and right angle gearboxes are available in every performance class – in both shaft and flange designs.

Your solution – available immediately

Time is of the essence. That's why our racks and gears with mounted pinions are available quickly and easily. Benefit from short delivery times, flexible selection, and perfectly matched components – so your projects can start without delay and you can reach your goals faster.

High load capacity

The gearboxes are equipped with a particularly resilient output shaft bearing that has been specially developed for pinion applications.

- Tapered or angular contact roller bearings reliably transmit high radial and axial forces – even during dynamic cycles and under heavy loads.
- Wide selection of gearbox series, frame sizes, and gear ratios for optimum adaptation to speed and torque.

Easily configure CAD data

With our intuitive Tec Data Finder (TDF), you can quickly configure the right components. You will receive the 3D data for gearboxes with mounted pinions by email in no time. Also for the racks, 3D data is available to download from our website: <https://www.neugart.com/en/racks>

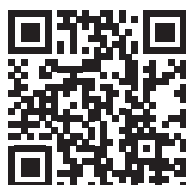

Quickly design rack and pinion drives

The powerful Neugart Calculation Program (NCP) allows you to easily enter your application parameters.

- Automatic selection of the optimal gearbox with pinion from the database
- Immediate calculation and visualization of results
- Convenient comparison of similar combinations for the best solution



SYSTEM ADVANTAGES AT A GLANCE

- **Flexible combinations:** Racks and pinions in various sizes with coaxial and right angle gearboxes
- **Precision & cost-effectiveness:** Choice between high-precision gearboxes and robust economy solutions
- **High load capacity:** Bearing technology for large radial and axial forces in dynamic applications
- **Fast availability:** Short-term delivery for projects without delay
- **Simple configuration:** CAD data available for immediate download

Rack		NRS	20	-	6	B	1000	-	R	1	
Description		NRS - Neugart Rack System								Helix angle	
Module		<ul style="list-style-type: none"> 15 Module 1.5 20 Module 2 30 Module 3 40 Module 4 50 Module 5 								<ul style="list-style-type: none"> 1 19°31'42" (19.5283°) 0 0° 	
Quality		6 Q6								Flank direction	
Stress level		B Stress level B								<ul style="list-style-type: none"> R right-hand L straight 	
										Length (mm)	
										1000 Helical rack	
										2000	
										1005 Straight rack	
										1018	
										2011	
										2036	

Pinion		PK1	-	20	-	16	-	S	
Pinion type		PK1						Helix angle	
		PM1						<ul style="list-style-type: none"> S -19°31'42" (-19.5283°) L 0° 	
		PM2							
Module		<ul style="list-style-type: none"> 15 Module 1.5 20 Module 2 30 Module 3 40 Module 4 50 Module 5 						Number of teeth	

The pinion is factory-mounted on the gearbox.
 The pinion product code is therefore part of the gearbox product code.

Example:
 PSNpro070-005-SSSK3AC-Z11/23/40/63/B5/M5-**PK1-20-16-S**

Helical rack

Helix angle $\beta = 19^\circ 31' 42''$ (19,5283°); right-hand

Neugart tempered steel, hardened (HRC 56-60)

Profile ground on all sides

Quality 6

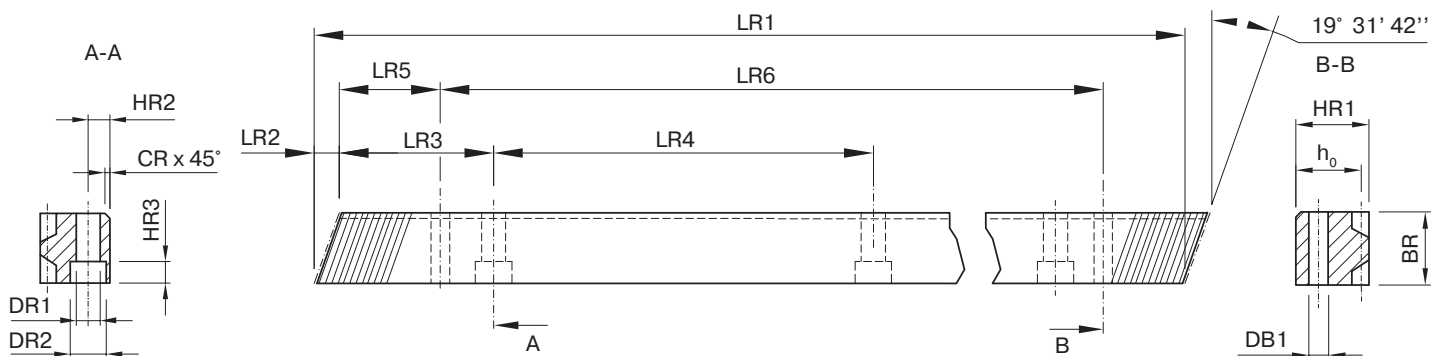

Product code	m	LR1	LR2	LR3	LR4	LR5	LR6	BR	HR1	HR2	DB1	CR	DR1	DR2	HR3	h ₀	z	Number of mounting holes
mm																		
NRS15-6B1000-R1	1,5	1000	6.739	62.5	125	29.94	939.42	19	19	8	5.7	2	7	11	7	17.5	200	8
NRS20-6B1000-R1	2	1000	8.512	62.5	125	31.71	936.58	24	24	8	5.7	2	7	11	7	22	150	8
NRS20-6B2000-R1	2	2000	8.512	62.5	125	31.71	1936.58	24	24	8	5.7	2	7	11	7	22	300	16
NRS30-6B1000-R1	3	1000	10.286	62.5	125	34.99	930.02	29	29	9	7.7	2	9	15	9	26	100	8
NRS30-6B2000-R1	3	2000	10.286	62.5	125	34.99	1930.02	29	29	9	7.7	2	9	15	9	26	200	16
NRS40-6B1000-R1	4	1000	13.832	62.5	125	33.30	933.40	39	39	12	7.7	3	9	15	9	35	75	8
NRS40-6B2000-R1	4	2000	13.832	62.5	125	33.30	1933.40	39	39	12	7.7	3	9	15	9	35	150	16

Product code	Article no.	m	LR1	Weight
		mm		kg
NRS15-6B1000-R1	100789973	1.5	1000	2.52
NRS20-6B1000-R1	100777056	2	1000	4.03
NRS20-6B2000-R1	100777057	2	2000	8.07
NRS30-6B1000-R1	100789982	3	1000	5.66
NRS30-6B2000-R1	100789984	3	2000	11.34
NRS40-6B1000-R1	100789986	4	1000	10.37
NRS40-6B2000-R1	100789988	4	2000	20.76



Straight rack

Helix angle $\beta = 0^\circ$

Neugart tempered steel, hardened (HRC 56-60)

Profile ground on all sides

Quality 6

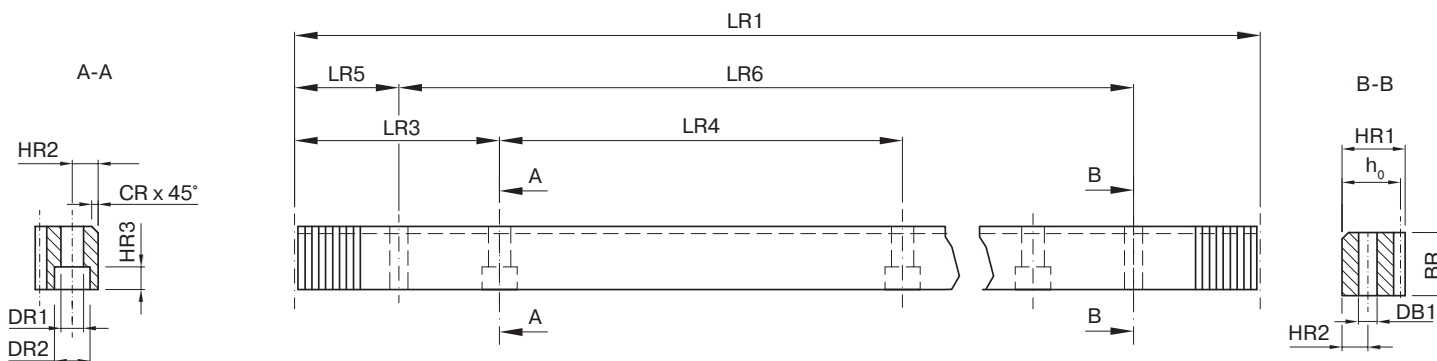

Product code	m	LR1	LR3	LR4	LR5	LR6	BR	HR1	HR2	DB1	CR	DR1	DR2	HR3	h ₀	z	Number of mounting holes
mm																	
NRS15-6B1018-L0	1.5	1017.876	63.617	127.235	34.4	949.076	19	19	8	5.7	2	7	11	7	17.5	216	8
NRS20-6B1005-L0	2	1005.310	62.832	125.664	31.3	942.710	24	24	8	5.7	2	7	11	7	22	160	8
NRS20-6B2011-L0	2	2010.619	62.832	125.664	31.3	1948.019	24	24	8	5.7	2	7	11	7	22	320	16
NRS30-6B1018-L0	3	1017.876	63.617	127.235	34.4	949.076	29	29	9	7.7	2	10	15	9	26	108	8
NRS30-6B2036-L0	3	2035.752	63.617	127.235	34.4	1966.952	29	29	9	7.7	2	10	15	9	26	216	16
NRS40-6B1005-L0	4	1005.310	62.832	125.664	37.5	930.310	39	39	12	7.7	3	10	15	9	35	80	8
NRS40-6B2011-L0	4	2010.619	62.832	125.664	37.5	1935.619	39	39	12	7.7	3	10	15	9	35	160	16
NRS50-6B1005-L0	5	1005.310	62.832	125.664	30.1	945.110	49	39	12	11.7	3	14	20	13	34	64	8
NRS50-6B2011-L0	5	2010.619	62.832	125.664	30.1	1950.419	49	39	12	11.7	3	14	20	13	34	128	16

Product code	Article no.	m	LR1	Weight
mm				kg
NRS15-6B1018-L0	100789990	1.5	1017.876	2.56
NRS20-6B1005-L0	100789992	2	1005.310	4.05
NRS20-6B2011-L0	100790009	2	2010.619	8.11
NRS30-6B1018-L0	100790003	3	1017.876	5.76
NRS30-6B2036-L0	100790011	3	2035.752	11.55
NRS40-6B1005-L0	100790005	4	1005.310	10.42
NRS40-6B2011-L0	100790017	4	2010.619	20.87
NRS50-6B1005-L0	100790007	5	1005.310	12.34
NRS50-6B2011-L0	100790019	5	2010.619	24.76



Permissible feed force

The permissible feed force provides the description of the maximum force that the rack can transmit in the feed direction. This is determined by the mechanical properties of the material used and the respective operating conditions.

The tables are based on the combinations of module and number of teeth specified in the catalog for Neugart racks and pinions. Other combinations can be designed on request.

Helical toothed					Straight toothed				
Pinion				Rack Tempered steel - Load level B	Pinion				Rack Tempered steel - Load level B
Module [mm]	Pinion type	Number of teeth	Max. torque [Nm]	Max. feed force [N]	Module [mm]	Pinion- type	Number of teeth	Max. torque [Nm]	Max. feed force [N]
1.5	PK1	19	68	4,520	1.5	PK1	20	43	2,860
2	PM2	20	232	10,930	2	PM2	22	194	8,840
3	PK1	24	660	17,270	3	PK1	25	525	14,000
4	PK1	20	1,295	30,510	4	PK1	22	986	22,400
5	-	-	-	-	5	PK1	19	1,481	31,170

The values listed in the tables refer to the transverse component (see picture: "F") of the force transmitted between the pinion and the rack.

Increasing the number of teeth on the pinion results in a slight increase in the permissible feed force. However, choosing a larger module has a significantly greater effect. The type of gearing and the material used also have a considerable influence on the load capacity of the gear racks.

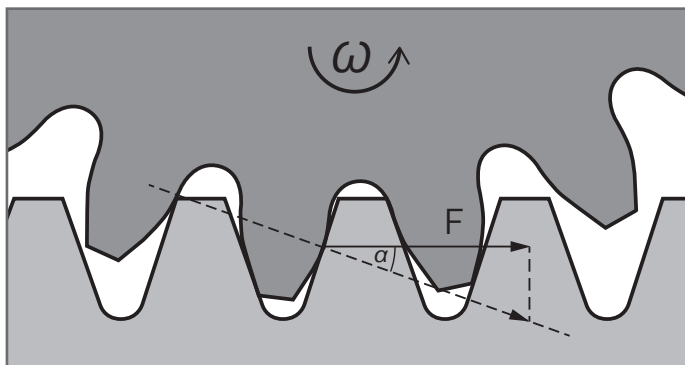

CALCULATION DATA:

Pressure angle $\alpha = 20^\circ$
 Profile modification factor $x = 0$
 Pinion material: 1.7160
 Case hardened
 Useful service life: infinite

Heat treatment / Surface treatment

The aim of heat treatment is to create particularly hard surfaces that offer high resilience and excellent wear and fatigue resistance. It plays a material role in giving mechanical components both strength and elasticity.

For standard racks, Neugart uses a tempered steel with an achievable hardness of approximately 56–60 HRC, which offers an optimal combination of surface hardness and mechanical resilience—tailored to the respective application.

Induction hardening

Two induction hardening processes are used for surface hardening of racks. The first process is scanning hardening, which is particularly suitable for racks up to module 4.

It produces deep hardening across the entire tooth, ensuring high hardness and excellent mechanical strength.

The second method is tooth-by-tooth induction hardening, which is used from module 5 onwards. This method enables targeted hardening of the tooth flanks, while the tooth core remains in its original state. The hardening depth is uniform across the entire tooth width.

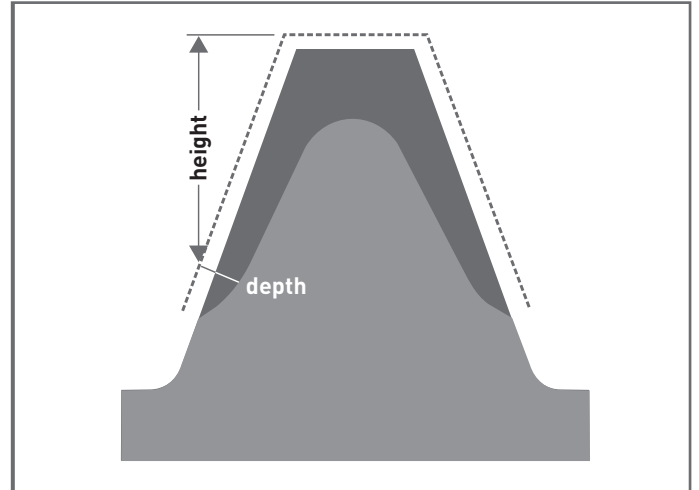

Tooth-by-tooth induction hardening

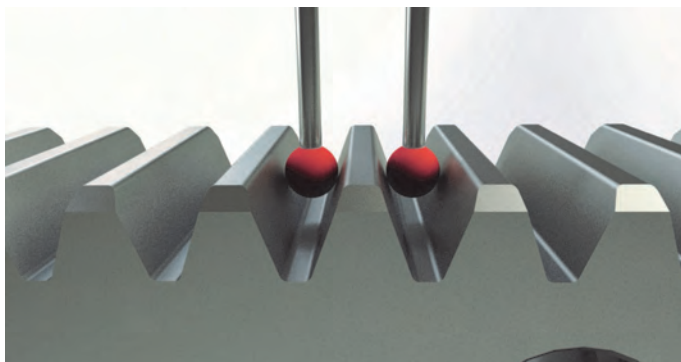

Individual pitch

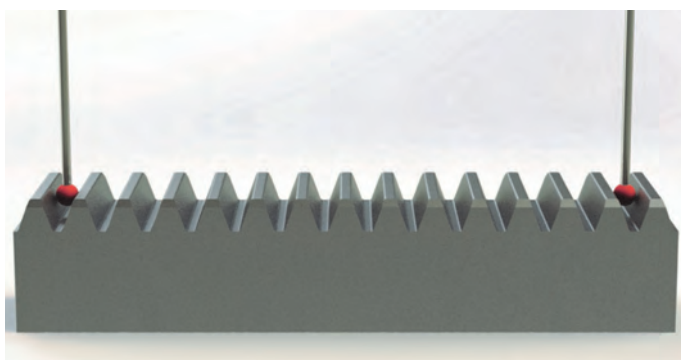

Total pitch

Individual pitch and total pitch

The pitch of a rack provides a description of the distance between the individual teeth. A distinction is made between the single pitch, which is measured directly between two consecutive teeth, and the total pitch, which covers the distance from the first to the last tooth of the rack.

A special testing procedure based on three-dimensional measuring systems is used to precisely determine dimensional deviations. This technology enables a particularly accurate analysis of deviations in tooth pitch, errors in overall pitch, and the general quality of the component.

The permissible tolerances for individual and total pitch depend on the module and the length of the rack. The dimensional accuracy is always evaluated in relation to the pitch circle of the corresponding gear, which serves as a reference for geometric accuracy.

Quality characteristics of racks

Quality class	Gearing type	Module	Length (mm)	Quality tolerance Tooth thickness (mm)	Individual pitch error (mm)	Total pitch error (mm)
Q6	Helical toothed	1.5	1,000	- 0.050	± 0.008	± 0.032
		2	1,000	- 0.036	± 0.008	± 0.035
		2	2,000	- 0.036	± 0.008	± 0.035
		3	1,000	- 0.036	± 0.009	± 0.035
		3	2,000	- 0.036	± 0.009	± 0.040
		4	1,000	- 0.029	± 0.009	± 0.035
		4	2,000	- 0.029	± 0.009	± 0.045
		4	2,000	- 0.029	± 0.009	± 0.045
	Straight toothed	1.5	1,018	- 0.050	± 0.008	± 0.032
		2	1,005	- 0.036	± 0.008	± 0.035
		2	2,011	- 0.036	± 0.008	± 0.035
		3	1,018	- 0.036	± 0.009	± 0.035
		3	2,036	- 0.036	± 0.009	± 0.040
		4	1,005	- 0.029	± 0.009	± 0.035
		4	2,011	- 0.029	± 0.009	± 0.045
		5	1,005	- 0.036	± 0.010	± 0.040
5	2,011	- 0.036	± 0.010	± 0.045		

Calculate the maximum total pitch error for racks

$$F_{pt} = (F_p * NR) + (M_p * VZ)$$

Example:

Total length: 4 m

Module: 3

Quality class: Q6

Helical toothed

Design variant A:

Rack length	2000 mm
Number of racks (NR)	2
Total rack pitch error (F _p)	0.040 mm
Connection error (M _p)	0.015 mm
Number of connections (VZ)	1

$$F_{pt} = (0.04 \text{ mm} * 2) + (0.015 * 1) = \underline{95 \mu\text{m}}$$

Design variant B:

Rack length	1000 mm
Number of racks (NR)	4
Total rack pitch error (F _p)	0.035 mm
Connection error (M _p)	0.015 mm
Number of connections (VZ)	3

$$F_{pt} = (0.035 \text{ mm} * 4) + (0.015 * 3) = \underline{185 \mu\text{m}}$$

The longer the individual rack, the lower the total pitch error for the same quality level.

F_{pt} = Maximum total pitch error of the rack drive

F_p = Total pitch error of individual rack

NR = Number of racks

M_p = Connection error (total pitch error of assembled rack, page 12)

VZ = Number of connections (rack joints)

Straightness and flatness

Racks may exhibit deviations in their straightness and flatness that are directly related to their length. These are caused by cold forming and/or stresses resulting from different heat treatment processes.

The following table illustrates the relationship between linear deviations and the respective length of the rack, which we guarantee, in accordance with the DIN ISO 2768 H standard with tolerance class H.

Tolerance class H Nominal size ranges (mm) rack length	Deviations in straightness and flatness (mm)
> 300 ≤ 1000	0.3
> 1000 ≤ 3000	0.4

For an exposed rack with a length of 1005 mm that has not yet been mounted on a machine, straightness and flatness within 0.4 mm can be guaranteed in accordance with DIN ISO 2768 H.

The material's natural elasticity allows the rack to be precisely mounted on the machine using accurately fitted

screws. This requires that the mounting surface meets the necessary tolerances in terms of flatness and squareness and that the recommended mounting procedures are carefully followed.

Under these conditions, near-perfect alignment with a deviation of less than 0.015 mm can be achieved.

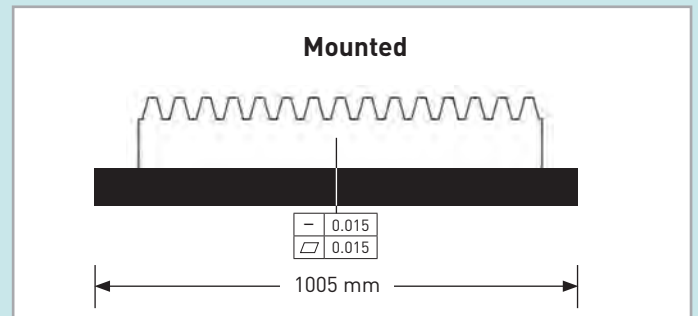
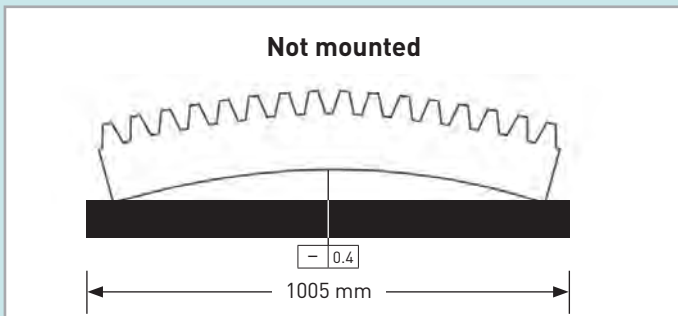

Helical toothed mounting rack

Helix angle $\beta = -19^\circ 31' 42''$ (-19.5283°); left-hand
 Induction hardened and ground

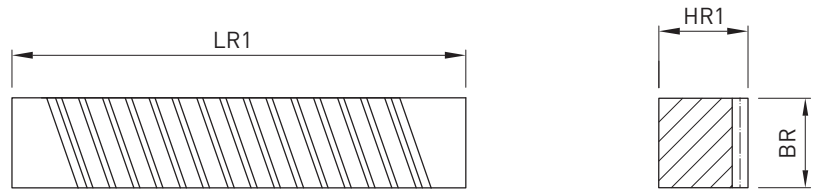

Straight toothed mounting rack

Helix angle $\beta = 0^\circ$
 Induction hardened and ground

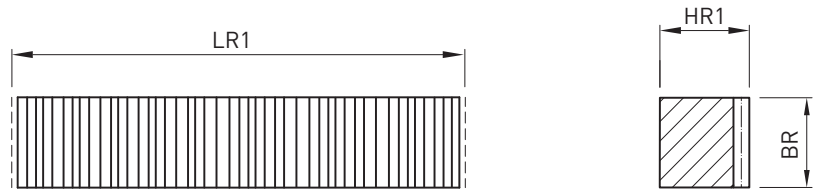

Quality characteristics of mounting racks

Gearing type	Article no. Mounting rack	Module	LR1	BR	HR1	z	Single pitch error (mm)	Total pitch error (mm)
Helical	100806731	1.5	110	19	19	20	0.004	0.015
	100806732	2	110	24	24	15	0.004	0.015
	100806733	3	110	29	29	9	0.004	0.015
	100806734	4	110	39	39	7	0.003	0.010
Straight	100806727	1.5	110	19	19	20	0.004	0.015
	100806728	2	110	24	24	15	0.004	0.015
	100806729	3	90	29	29	9	0.004	0.015
	100806730	4	90	39	39	7	0.003	0.010
	100806735	5	110	49	49	7	0.003	0.010

NOTE ON MOUNTING ACCESSORIES



If you require additional mounting accessories beyond those listed in this catalog or have questions about specific applications, we will be happy to advise you. Our team at Neugart will provide you with expert support in the selection of the right accessories and offer customized solutions for your requirements.

Please do not hesitate to contact us — we will help you quickly and easily. Together we will find the optimal solution for your application.

Planetary gearboxes with mounted pinion

Numerous combination options from three different pinion types with helical and straight teeth ensure that the ideal solution is available for every application.

The pinion can be combined with different gearbox types, including precision gearboxes for maximum accuracy, economy gears for maximum durability and efficiency, and angular planetary gears for special installation situations.

This allows you to benefit from maximum flexibility and technical coordination for a wide range of requirements.



PK1



- The PK1 pinion is mounted directly on the gearbox's toothed output shaft.
- The internal teeth in accordance with DIN 5480 ensure a form-fitting and secure connection between the pinion and the gearbox.
- The precise design of the internal teeth in accordance with DIN 5480 enables optimum power transmission and ensures a permanently high level of connection reliability, even in demanding applications.

PM1



- The PM1 pinion is specially designed for gearboxes with flange output shafts and features a mechanical interface standardized according to ISO 9409-1 for easy and secure installation.
- The standardized interface ensures high compatibility and connection reliability with various gearbox types.
- Thanks to its large circumference, the PM1 pinion enables particularly high feed speeds.

PM2



- The PM2 pinion is specially designed for gearboxes with flange output shafts and features a mechanical interface standardized according to ISO 9409-1 for easy and secure assembly.
- The standardized interface ensures high compatibility and connection reliability with various gearbox types.
- Thanks to its low number of teeth, the PM2 pinion enables particularly high feed forces.

Pinion with helical teeth

Helix angle $\beta = -19^{\circ}31'42''$ [-19.5283°]; left-hand

Hardened and ground, Quality 6



Pinion type	Module	Number of teeth	Pitch circle diameter	Profile modification factor	Feed constant	Pinion weight	Max. torque	Max. feed force	Suitable for gearbox ⁽¹⁾				
									PSNpro	WPLN	PLHE	WPLHE	PLPE
	m	z	d ₀	x	d ₀ x n	m _P	T _{Vmax}	F _V					
	mm		mm		mm/U	kg	Nm	N					
PK1	1.5	19	30.239	0.30	95.00	0.11	68	4,520	070	070	060	060	070
PK1	2	15	31.831	0.55	100.00	0.16	90	5,650					
PK1	2	16	33.953	0.55	106.67	0.18	103	6,060					
PK1	2	18	38.197	0.45	120.00	0.23	106	5,540	090	090	080	080	090
PK1	2	18	38.197	0.45	120.00	0.21	141	7,380					
PK1	2	20	42.441	0.45	133.33	0.27	183	8,620					
PK1	2	22	46.686	0.45	146.67	0.33	200	8,560	115	115	120	120	120
PK1	2	23	48.808	0.45	153.33	0.32	229	9,380					
PK1	2	25	53.052	0.45	166.67	0.39	250	9,420					
PK1	2	26	55.174	0.40	173.33	0.42	263	9,530	142	142	-	-	155
PK1	2	27	57.296	0.35	180.00	0.46	275	9,590					
PK1	3	20	63.662	0.45	200.00	0.69	436	13,700					
PK1	3	20	63.662	0.45	200.00	0.77	534	16,770	190	-	-	-	-
PK1	3	22	70.028	0.45	220.00	0.94	602	17,190					
PK1	3	24	76.394	0.45	240.00	1.12	660	17,270					
PK1	4	20	84.883	0.40	266.67	1.64	1,295	30,510					

Pinion with straight teeth

Helix angle $\beta = 0^{\circ}$

Hardened and ground, Quality 6



Pinion type	Module	Number of teeth	Pitch circle diameter	Profile modification factor	Feed constant	Pinion weight	Max. torque	Max. feed force	Suitable for gearbox ⁽¹⁾				
									PSNpro	WPLN	PLHE	WPLHE	PLPE
	m	z	d ₀	x	d ₀ x n	m _P	T _{Vmax}	F _V					
	mm		mm		mm/U	kg	Nm	N					
PK1	1.5	20	30.00	0.30	94.25	0.11	43	2,860	070	070	060	060	070
PK1	2	16	32.00	0.50	100.53	0.16	61	3,810					
PK1	2	19	38.00	0.40	119.38	0.22	94	4,950					
PK1	2	19	38.00	0.40	119.38	0.20	94	4,940	090	090	080	080	090
PK1	2	22	44.00	0.30	138.23	0.28	133	6,050					
PK1	3	17	51.00	0.40	160.22	0.40	225	8,820					
PK1	3	22	66.00	0.20	207.35	0.71	397	12,030	115	115	120	120	120
PK1	3	22	66.00	0.20	207.35	0.79	397	12,030					
PK1	3	25	75.00	0.20	235.62	1.04	525	14,000					
PK1	4	19	76.00	0.30	238.76	1.32	712	18,730	142	142	-	-	155
PK1	4	22	88.00	0.20	276.46	1.71	986	22,400					
PK1	5	19	95.00	0.40	298.45	2.38	1,481	31,170					
PK1	4	22	88.00	0.20	276.46	1.71	986	22,400	190	-	-	-	-

⁽¹⁾ Application-specific configuration with NCP. More information about the gearboxes can be found on the product pages or at www.neugart.com

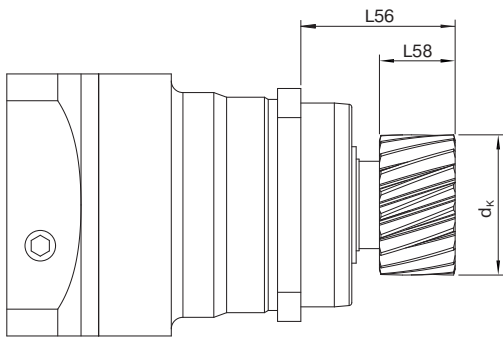

PSNpro with pinion
(also applies to WPLN, PLHE and WPLHE)

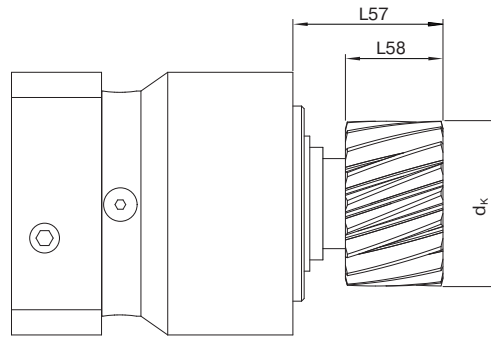

PLPE with pinion

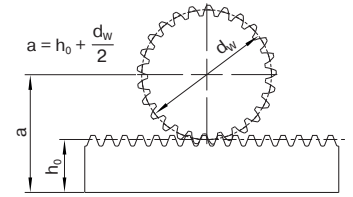

Pinion with helical teeth

Frame size	Pinion type	Module	Number of teeth	Tip diameter	Operating pitch circle diameter	Pinion width	Center distance ⁽¹⁾	Output shaft length with pinion	
		m	z	d_k	d_w		a	L56	L57
		mm		mm	mm	mm	mm	mm	
060 / 070	PK1	1.5	19	34.06	31.14	21	33.10	51	39.1
	PK1	2	15	37.95	34.03	26	39.02	52	40.1
	PK1	2	16	40.07	36.15	26	40.08	52	40.1
	PK1	2	18	43.92	40.00	26	42.00	52	40.1
080 / 090	PK1	2	18	43.92	40.00	26	42.00	52	42.9
	PK1	2	20	48.16	44.24	26	44.12	53	42.9
	PK1	2	22	52.40	48.49	26	46.24	53	42.9
115 / 120	PK1	2	23	54.53	50.61	26	47.30	64	54
	PK1	2	25	58.74	54.85	26	49.43	64	54
	PK1	2	26	60.66	56.77	26	50.39	64	54
	PK1	2	27	62.59	58.70	26	51.35	64	54
	PK1	3	20	72.25	66.36	31	59.18	69.5	59.5
142 / 155	PK1	3	20	72.25	66.36	31	59.18	81	65.9
	PK1	3	22	76.62	72.73	31	62.36	81	65.9
	PK1	3	24	84.99	79.09	31	65.55	81	65.9
190	PK1	4	20	95.97	88.08	41	79.04	84	-

Pinion with straight teeth

Frame size	Pinion type	Module	Number of teeth	Tip diameter	Operating pitch circle diameter	Pinion width	Center distance ⁽¹⁾	Output shaft length with pinion	
		m	z	d_k	d_w		a	L56	L57
		mm		mm	mm	mm	mm	mm	
060 / 070	PK1	1.5	20	33.82	30.90	21	32.95	51	39.1
	PK1	2	16	37.92	34.00	26	39.00	52	40.1
	PK1	2	19	43.52	39.60	26	41.80	52	40.1
080 / 090	PK1	2	19	43.52	39.60	26	41.80	53	42.9
	PK1	2	22	49.12	45.20	26	44.60	53	42.9
115 / 120	PK1	3	17	59.29	53.40	31	52.70	69.5	59.5
	PK1	3	22	73.09	67.20	31	59.60	69.5	59.5
142 / 155	PK1	3	22	73.09	67.20	31	59.60	81	59.5
	PK1	3	25	82.09	76.20	31	64.12	81	65.9
	PK1	4	19	86.29	78.40	41	74.20	84	68.9
190	PK1	4	22	97.49	89.60	41	79.80	84	-
	PK1	5	19	108.89	99.00	51	83.50	84	-

⁽¹⁾ For standard toothed rack height h_0 . Module 1.5 ($h_0 = 17.5$ mm), Module 2 ($h_0 = 22$ mm), Module 3 ($h_0 = 26$ mm), Module 4 ($h_0 = 35$ mm), Module 5 ($h_0 = 34$ mm).

Pinion with helical teeth

Helix angle $\beta = -19^{\circ}31'42''$ (-19.5283°); left-hand

Hardened and ground, Quality 6

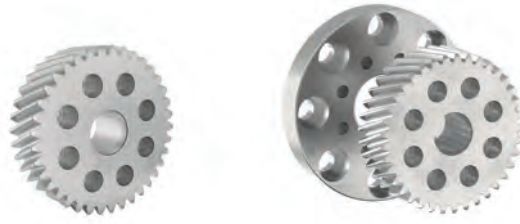

Pinion type	Module	Number of teeth	Adapter flange (inclusive) ^{2) 3)}	Pitch circle diameter	Profile modification factor	Feed constant	Pinion weight	Max. torque	Max. feed force	Suitable for gearbox ⁽¹⁾			Mounting method
										PSFNpro	WPSFN	PFHE	
	m	z		d ₀	x	d ₀ x n	m _p	T _{vmax}	F _v				
	mm			mm		mm/U	kg	Nm	N				
PM1	2	26	-	55.174	0.40	173.33	0.43	81	2,930	064	064	064	2)
PM1	2	27	-	57.296	0.35	180.00	0.47	82	2,860				
PM1	2	26	064 → 090	55.174	0.40	173.33	0.60	81	2,930	090	090	090	3)
PM1	2	27	064 → 090	57.296	0.35	180.00	0.64	82	2,860				
PM1	2	35	064 → 090	74.272	0.35	233.33	1.00	90	2,420				
PM1	2	37	-	78.517	0.35	246.67	0.89	176	4,480	090	090	090	2)
PM1	2	26	064 → 110	55.174	0.40	173.33	0.76	81	2,930				
PM1	2	27	064 → 110	57.296	0.35	180.00	0.79	82	2,860	110	110	110	3)
PM1	2	35	064 → 110	74.272	0.35	233.33	1.16	90	2,420				
PM1	2	40	-	84.883	0.35	266.67	0.94	312	7,350	110	110	110	2)
PM1	2	45	-	95.493	0.30	300.00	1.25	328	6,860				
PM1	2	37	090 → 140	78.517	0.35	246.67	1.54	176	4,480	140	140	-	3)
PM1	3	31	090 → 140	98.676	0.35	310.00	2.40	193	3,910				
PM1	3	35	-	111.409	0.35	350.00	2.18	783	14,050				
PM1	3	40	-	127.324	0.35	400.00	2.92	829	13,020	140	140	-	2)
PM1	4	30	-	127.324	0.20	400.00	3.67	827	12,990				
PM1	3	35	140 → 200	111.409	0.35	350.00	4.20	783	14,050				
PM1	3	40	140 → 200	127.324	0.35	400.00	4.93	829	13,020	200	-	-	3)
PM1	4	30	140 → 200	127.324	0.20	400.00	5.68	827	12,990				

⁽¹⁾ Application specific configuration with NCP. More information about the gearboxes can be found on the product pages or at www.neugart.com

²⁾ Direct mounting of the pinion



PSFNpro090 with PM1 pinion for gearbox size 090

³⁾ Use of an adapter flange for installing the pinion

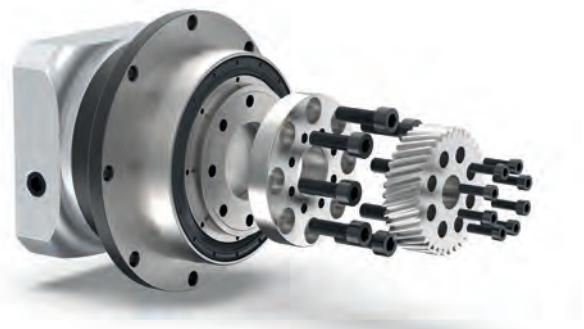

PSFNpro090 with adapter flange (064 → 090) and PM1 pinion for gearbox frame size 064

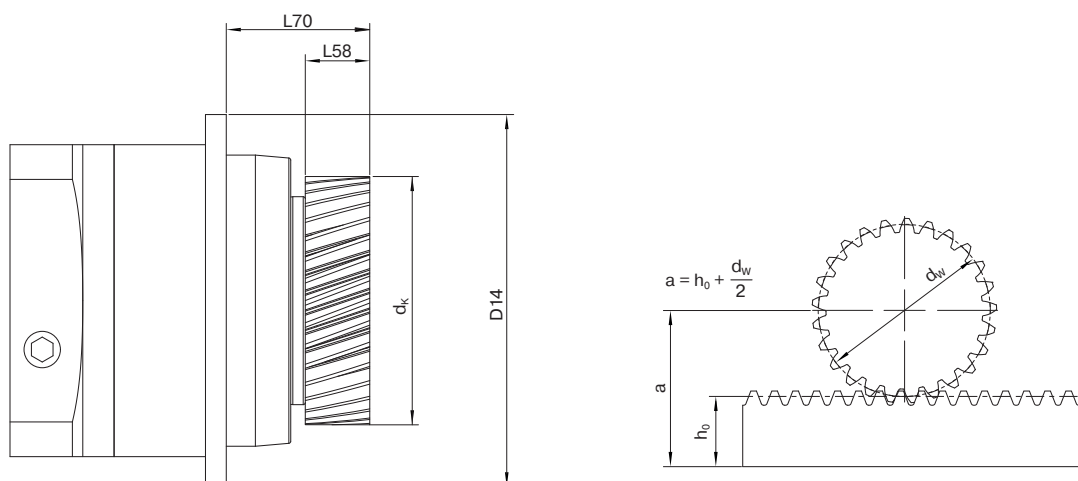

Pinion with helical teeth

Frame size	Pinion type	Module	Number of teeth	Adapter flange (inclusive)	Tip diameter	Operating pitch circle diameter	Pinion width	Center distance ⁽¹⁾	Flange diameter	Output shaft length with pinion
		m	z		dk	dw	L58	a	D14	L70
		mm			mm	mm	mm	mm	mm	
064	PM1	2	26	-	60.66	56.77	26	50.39	86	45.5
	PM1	2	27	-	62.59	58.70	26	51.35	86	45.5
090	PM1	2	26	064 → 090	60.66	56.77	26	50.39	118	66
	PM1	2	27	064 → 090	62.59	58.70	26	51.35	118	66
	PM1	2	35	064 → 090	79.56	75.67	26	59.84	118	66
	PM1	2	37	-	83.81	79.92	26	61.96	118	56
110	PM1	2	26	064 → 110	60.66	56.77	26	50.39	145	65
	PM1	2	27	064 → 110	62.59	58.70	26	51.35	145	65
	PM1	2	35	064 → 110	79.56	75.67	26	59.84	145	65
	PM1	2	40	-	90.17	86.28	26	65.14	145	55
	PM1	2	45	-	100.58	96.69	26	70.35	145	55
140	PM1	2	37	090 → 140	83.81	79.92	26	61.96	179	77
	PM1	3	31	090 → 140	106.67	100.78	31	76.39	179	82
	PM1	3	35	-	119.40	113.51	31	82,75	179	69
	PM1	3	40	-	135.27	139.42	31	90.71	179	69
	PM1	4	30	-	136.77	128.92	41	99.46	179	79
200	PM1	3	35	140 → 200	119.40	113.51	31	82.75	247	100
	PM1	3	40	140 → 200	135.27	129.42	31	90.71	247	100
	PM1	4	30	140 → 200	136.77	128.92	41	99.46	247	110

⁽¹⁾ For standard toothed rack height h₀. Module 2 [h₀ = 22 mm], Module 3 [h₀ = 26 mm], Module 4 [h₀ = 35 mm].

Pinion with helical teeth

Helix angle $\beta = -19^\circ 31' 42''$ (-19.5283°); left-hand
hardened and ground, Quality 6



Pinion type	Module	Number of teeth	Pitch circle diameter	Profile modification factor	Feed constant	Pinion weight	Max. torque	Max. feed force	Suitable for gearbox ⁽¹⁾		
									PSFNpro	WPSFN	PFHE
	m	z	d_0	x	$d_0 \times \pi$	m_p	T_{vmax}	F_v			
	mm		mm		mm/U	kg	Nm	N			
PM2	2	16	33.95	0.25	106.67	0.46	124	7,300	090	090	090
PM2	2	20	42.44	0.45	133.33	0.81	226	10,650	110	110	110
PM2	3	14	44.56	0.20	140.00	0.89	228	10,230			
PM2	2	20	42.44	0.45	133.33	1.15	232	10,930	140	140	-
PM2	3	17	54.11	0.45	170.00	3.16	350	12,930			
PM2	3	17	54.11	0.45	170.00	1.41	350	12,930	200	-	-
PM2	4	20	84.88	0.40	266.67	4.47	1279	30,140			

Pinion with straight teeth

Helix angle $\beta = 0^\circ$
hardened and ground, Quality 6



Pinion type	Module	Number of teeth	Pitch circle diameter	Profile modification factor	Feed constant	Pinion weight	Max. torque	Max. feed force	Suitable for gearbox ⁽¹⁾		
									PSFNpro	WPSFN	PFHE
	m	z	d_0	x	$d_0 \times \pi$	m_p	T_{vmax}	F_v			
	mm		mm		mm/U	kg	Nm	N			
PM2	2	17	34.00	0.20	106.81	0.45	98	5,780	090	090	090
PM2	2	22	44.00	0.40	138.23	0.82	194	8,840	110	110	110
PM2	3	19	57.00	0.40	179.07	1.46	275	9,650	140	140	-
PM2	4	22	88.00	0.20	276.46	4.54	847	19,260	200	-	-
PM2	5	19	95.00	0.20	298.45	5.41	1,304	27,460			

⁽¹⁾ Application specific configuration with NCP. More information about the gearboxes can be found on the product pages or at www.neugart.com

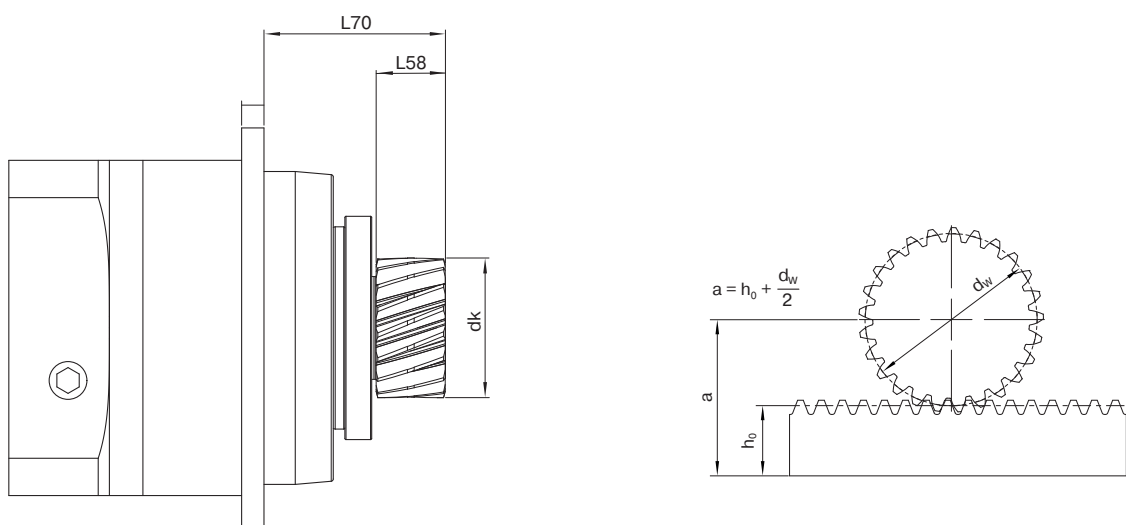

Pinion with helical teeth

Frame size	Pinion type	Module	Number of teeth	Tip diameter	Operating pitch circle diameter	Pinion width	Center distance ⁽¹⁾	Output shaft length with pinion
		m	z	d_k	d_w	L58	a	L70
		mm		mm	mm	mm	mm	
090	PM2	2	16	38.87	34.95	26	39.48	66.45
110	PM2	2	20	48.16	44.24	26	44.12	67.45
	PM2	3	14	51.68	45.76	31	43.88	72.45
140	PM2	2	20	48.16	44.24	26	44.12	77.45
	PM2	3	17	62.70	56.81	31	49.41	101.00
200	PM2	3	17	62.70	56.81	31	49.41	83.00
	PM2	4	20	95.97	88.08	41	64.04	111.00

Pinion with straight teeth

Frame size	Pinion type	Module	Number of teeth	Tip diameter	Operating pitch circle diameter	Pinion width	Center distance ⁽¹⁾	Output shaft length with pinion
		m	z	d_k	d_w	L58	a	L70
		mm		mm	mm	mm	mm	
090	PM2	2	17	38.72	34.80	26	39.40	66.45
110	PM2	2	22	49.52	45.60	26	44.80	67.45
140	PM2	3	19	65.29	59.40	31	50.70	83.00
200	PM2	4	22	97.49	89.60	41	64.80	111.00
	PM2	5	19	106.89	97.00	51	67.50	121.00

⁽¹⁾ For standard toothed rack height h_0 . Module 2 ($h_0 = 22$ mm), Module 3 ($h_0 = 26$ mm), Module 4 ($h_0 = 35$ mm), Module 5 ($h_0 = 34$ mm).



Do you have any questions or need further information?

We are happy to advise you on all topics relating to drive technology.

You can find your personal contact at: www.neugart.com

Neugart GmbH

Keltenstraße 16
77971 Kippenheim
Germany
Phone: +49 7825 847-0
Email: sales@neugart.com
Web: www.neugart.com

Neugart USA Corp.

14325 South Lakes Drive
Charlotte, NC 28273
USA
Phone: +1 980 299-9800
Email: sales@neugartusa.com
Web: www.neugart.com/en-us

Neugart Planetary Gearboxes (Shenyang) Co., Ltd.

No.152, 22nd road
E&T Development Zone Shenyang, PC 110143
PR China
Phone: +86 24 2537-4959
Email: sales@neugart.net.cn
Web: www.neugart.net.cn