

# PSBN

## The high-performance precision planetary gearbox with helical gearing for a particularly quiet drive

Our **PSBN** is the ideal combination of precision planetary gearbox and efficient bearing technology. It has been developed specifically for delivering the maximum performance at high speeds. Its helical teeth provide homogeneous synchronism and quiet running noise.

Nominal output torque **28 - 470 Nm**



Radial force **1000 - 5800 N**



Axial force **1500 - 9400 N**



Torsional backlash **1 - 5 arcmin**

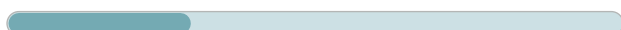

Protection class **IP65**



Frame sizes

- 70
- 90
- 115
- 142

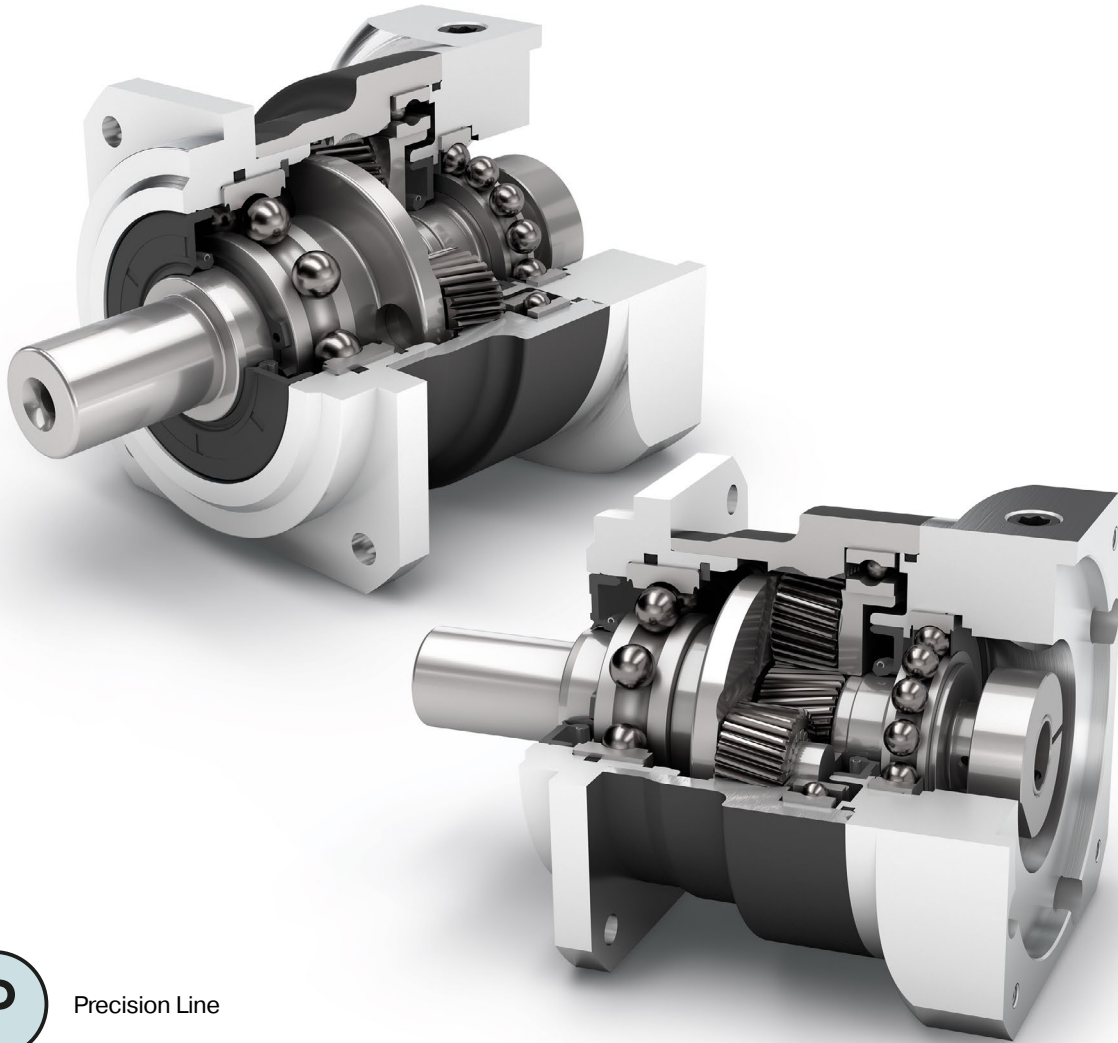

Precision Line



Coaxial gearbox



Helical gear



Low-friction deep groove ball bearings



Planet carrier in cage design



Equidirectional rotation



Square type output flange



Rotary shaft seal



Option: Reduced backlash

Detailed explanations of the technical features starting on page 169.

Code	Gearbox characteristics			PSBN070	PSBN090	PSBN115	PSBN142	p <sup>(1)</sup>
	Service life (L <sub>10h</sub> )	t <sub>L</sub>	h	20,000				
	Service life at T <sub>2N</sub> x 0,88			30,000				
	Efficiency at full load <sup>(2)</sup>	η	%	98				1
				96				2
	Min. operating temperature	T <sub>min</sub>	°C	-25 (-13)				
	Max. operating temperature	T <sub>max</sub>	(°F)	90 (194)				
	Protection class				IP65			
<b>S</b>	Standard lubrication				Oil (lifetime lubrication)			
<b>F</b>	Food grade lubrication				Oil (lifetime lubrication)			
<b>L</b>	Low temperature lubrication <sup>(3)</sup>				Oil (lifetime lubrication)			
	Installation position				Any			
<b>S</b>	Standard backlash	j <sub>t</sub>	arcmin	< 3				1
<b>R</b>	Reduced backlash			< 5				2
	Torsional stiffness <sup>(2)</sup>	c <sub>g</sub>	Nm /arcmin (lb <sub>f</sub> .in/ arcmin)	4.1 - 5.4 (36 - 48)	9.3 - 12.8 (82 - 113)	22.5 - 32.5 (199 - 288)	59.5 - 76.0 (527 - 673)	1
				4.1 - 5.7 (36 - 50)	10.2 - 13.4 (90 - 119)	25.5 - 35.0 (226 - 310)	57.5 - 71.0 (509 - 628)	2
	Gearbox weight <sup>(2)</sup>	m <sub>G</sub>	kg (lb <sub>m</sub> )	1.4 - 1.5 (3.1 - 3.3)	2.8 - 2.9 (6.2 - 6.3)	5.4 - 5.8 (12.0 - 12.8)	13.4 - 13.7 (29.6 - 30.3)	1
				2.1 (4.6)	3.4 - 3.5 (7.4 - 7.6)	6.7 - 6.9 (14.7 - 15.1)	15.4 - 15.8 (33.9 - 34.8)	2
<b>S</b>	Standard surface				Housing: Steel – heat-treated and post-oxidized (black)			
	Running noise <sup>(4)</sup>	Q <sub>g</sub>	dB(A)	57	58	63	66	
	Max. bending moment based on the gearbox input flange <sup>(5)</sup>	M <sub>b</sub>	Nm (lb <sub>f</sub> .in)	18 (159)	38 (336)	80 (708)	180 (1593)	1
				18 (159)	18 (159)	38 (336)	80 (708)	2

Output shaft loads			PSBN070	PSBN090	PSBN115	PSBN142	p <sup>(1)</sup>
Radial force for 20,000 h <sup>(6)(7)</sup>	F <sub>r,20.000h</sub>	N (lb <sub>f</sub> )	1000 (225)	1900 (427)	2300 (517)	4200 - 5800 (944 - 1304)	
Axial force for 20,000 h <sup>(6)(7)</sup>	F <sub>a,20.000h</sub>		1500 (337)	3000 (674)	4400 (989)	9400 (2113)	
Radial force for 30,000 h <sup>(6)(7)</sup>	F <sub>r,30.000h</sub>		850 (191)	1700 (382)	2000 (450)	3700 - 5100 (832 - 1147)	
Axial force for 30,000 h <sup>(6)(7)</sup>	F <sub>a,30.000h</sub>		1300 (292)	2500 (562)	3700 (832)	7700 (1731)	
Maximum radial force <sup>(7)(8)</sup>	F <sub>r,Stat</sub>		1600 (360)	3100 (697)	4500 (1012)	9500 (2136)	
Maximum axial force <sup>(7)(8)</sup>	F <sub>a,Stat</sub>		1500 (337)	2800 (629)	4500 (1012)	9600 (2158)	
Tilting moment for 20,000 h <sup>(6)(8)</sup>	M <sub>K,20.000h</sub>	Nm (lb <sub>f</sub> .in)	68 (602)	154 (1363)	226 (2000)	565 - 794 (5001 - 7027)	
Tilting moment for 30,000 h <sup>(6)(8)</sup>	M <sub>K,30.000h</sub>		58 (513)	138 (1221)	197 (1744)	495 - 697 (4381 - 6169)	

Moment of inertia			PSBN070	PSBN090	PSBN115	PSBN142	p <sup>(1)</sup>
Mass moment of inertia <sup>(2)</sup>	J	kgcm <sup>2</sup> (lb <sub>f</sub> .in.s <sup>2</sup> 10 <sup>-4</sup> )	0.127 - 0.260 (1.124 - 2.301)	0.327 - 0.785 (2.894 - 6.948)	0.874 - 2.650 (7.736 - 23.454)	6.539 - 14.440 (57.875 - 127.805)	1
			0.123 - 0.175 (1.089 - 1.549)	0.124 - 0.200 (1.097 - 1.770)	0.321 - 0.600 (2.841 - 5.310)	0.841 - 2.003 (7.443 - 17.728)	2

(1) Number of stages  
 (2) The ratio-dependent values can be retrieved in Tec Data Finder – www.neugart.com  
 (3) T<sub>min</sub> = -40°C. Optimal operating temperature max. 50°C  
 (4) Sound pressure level from 1 m, measured on input running at n<sub>i</sub>=3000 rpm no load; i=5  
 (5) Max. motor weight\* in kg = 0.2 x M<sub>b</sub> / motor length in m  
 \* with symmetrically distributed motor weight  
 \* with horizontal and stationary mounting  
 (6) These values are based on an output shaft speed of n<sub>2</sub>=100 rpm  
 (7) Based on center of output shaft  
 (8) Other (sometimes higher) values following changes to T<sub>2N</sub>, F<sub>r</sub>, F<sub>a</sub>, cycle, and service life of bearing. Application specific configuration with NCP – www.neugart.com

Output torques			PSBN070	PSBN090	PSBN115	PSBN142	i <sup>(1)</sup>	p <sup>(2)</sup>
Nominal output torque <sup>(3)(4)</sup>	T <sub>2N</sub>	Nm (lb <sub>r</sub> .in)	29 (257)	54 (478)	135 (1195)	380 (3363)	3	1
			39 (345)	80 (708)	180 (1593)	470 (4160)	4	
			40 (354)	80 (708)	175 (1549)	405 (3585)	5	
			37 (327)	78 (690)	175 (1549)	355 (3142)	7	
			39 (345)	75 (664)	155 (1372)	350 (3098)	8	
			28 (248)	59 (522)	140 (1239)	305 (2699)	10	
			29 (257)	54 (478)	135 (1195)	380 (3363)	12	
			29 (257)	54 (478)	135 (1195)	380 (3363)	15	
		2	39 (345)	80 (708)	180 (1593)	450 (3983)	16	
			39 (345)	80 (708)	180 (1593)	450 (3983)	20	
			40 (354)	80 (708)	175 (1549)	405 (3585)	25	
			40 (354)	80 (708)	175 (1549)	405 (3585)	35	
			39 (345)	80 (708)	180 (1593)	470 (4160)	40	
			40 (354)	80 (708)	175 (1549)	405 (3585)	50	
			37 (327)	78 (690)	175 (1549)	355 (3142)	70	
			28 (248)	59 (522)	140 (1239)	305 (2699)	100	
Max. output torque <sup>(4)(5)</sup>	T <sub>2max</sub>	Nm (lb <sub>r</sub> .in)	46 (407)	86 (761)	216 (1912)	608 (5381)	3	1
			62 (549)	128 (1133)	288 (2549)	752 (6656)	4	
			64 (566)	128 (1133)	280 (2478)	648 (5735)	5	
			59 (522)	125 (1106)	280 (2478)	568 (5027)	7	
			62 (549)	120 (1062)	248 (2195)	560 (4956)	8	
			45 (398)	94 (832)	224 (1983)	488 (4319)	10	
			46 (407)	86 (761)	216 (1912)	608 (5381)	12	
			46 (407)	86 (761)	216 (1912)	608 (5381)	15	
		2	62 (549)	128 (1133)	288 (2549)	720 (6373)	16	
			62 (549)	128 (1133)	288 (2549)	720 (6373)	20	
			64 (566)	128 (1133)	280 (2478)	648 (5735)	25	
			64 (566)	128 (1133)	280 (2478)	648 (5735)	35	
			62 (549)	128 (1133)	288 (2549)	752 (6656)	40	
			64 (566)	128 (1133)	280 (2478)	648 (5735)	50	
			59 (522)	125 (1106)	280 (2478)	568 (5027)	70	
			45 (398)	94 (832)	224 (1983)	488 (4319)	100	

(1) Ratios (i=n<sub>1</sub>/n<sub>2</sub>)  
 (2) Number of stages  
 (3) Application specific configuration with NCP – www.neugart.com  
 (4) Values for feather key (code "A"): for repeated load  
 (5) 30,000 rotations of the output shaft permitted; see page 158

Output torques			PSBN070	PSBN090	PSBN115	PSBN142	i <sup>(1)</sup>	p <sup>(2)</sup>
Emergency stop torque <sup>(3)</sup>	T <sub>2Stop</sub>	Nm (lb <sub>r</sub> .in)	90 (797)	210 (1859)	490 (4337)	1250 (11063)	3	1
			120 (1062)	280 (2478)	650 (5753)	1650 (14604)	4	
			130 (1151)	280 (2478)	650 (5753)	1650 (14604)	5	
			80 (708)	175 (1549)	340 (3009)	1300 (11506)	7	
			90 (797)	200 (1770)	380 (3363)	1100 (9736)	8	
			90 (797)	200 (1770)	480 (4248)	600 (5310)	10	
		135 (1195)	220 (1947)	500 (4425)	1250 (11063)	12	2	
		135 (1195)	220 (1947)	500 (4425)	1250 (11063)	15		
		150 (1328)	300 (2655)	650 (5753)	1650 (14604)	16		
		150 (1328)	300 (2655)	650 (5753)	1650 (14604)	20		
		150 (1328)	300 (2655)	650 (5753)	1650 (14604)	25		
		150 (1328)	300 (2655)	650 (5753)	1650 (14604)	35		
		150 (1328)	300 (2655)	650 (5753)	1650 (14604)	40		
		150 (1328)	300 (2655)	650 (5753)	1650 (14604)	50		
		80 (708)	175 (1549)	340 (3009)	1300 (11506)	70		
		80 (708)	200 (1770)	480 (4248)	600 (5310)	100		

Input speeds			PSBN070	PSBN090	PSBN115	PSBN142	i <sup>(1)</sup>	p <sup>(2)</sup>
Average thermal input speed at T <sub>2N</sub> and S1 <sup>(4)(5)</sup>	n <sub>1N</sub>	rpm	3800 <sup>(6)</sup>	3400 <sup>(6)</sup>	2900 <sup>(6)</sup>	1600 <sup>(6)</sup>	3	1
			4400 <sup>(6)</sup>	3700 <sup>(6)</sup>	3000 <sup>(6)</sup>	1950 <sup>(6)</sup>	4	
			4600 <sup>(6)</sup>	3900 <sup>(6)</sup>	3500 <sup>(6)</sup>	2350 <sup>(6)</sup>	5	
			5000	4500	4000 <sup>(6)</sup>	3150 <sup>(6)</sup>	7	
			5000	4500	4000	3450 <sup>(6)</sup>	8	
			5000	4500	4000	3500	10	
			5000	5000	4500	3150 <sup>(6)</sup>	12	2
			5000	5000	4500	3950 <sup>(6)</sup>	15	
			5000	5000	4500	3400 <sup>(6)</sup>	16	
			5000	5000	4500	4000 <sup>(6)</sup>	20	
			5000	5000	4500	4000	25	
			5000	5000	4500	4000	35	
			5000	5000	4500	4000	40	
			5000	5000	4500	4000	50	
			5000	5000	4500	4000	70	
			5000	5000	4500	4000	100	
Max. mechanical input speed <sup>(4)</sup>	n <sub>1Limit</sub>	rpm	14000	10000	8500	6500		1
			14000	14000	10000	8500		2

(1) Ratios (i=n<sub>1</sub>/n<sub>2</sub>)  
 (2) Number of stages  
 (3) Permitted 1000 times  
 (4) Application-specific speed configurations with NCP – www.neugart.com  
 (5) See page 158 for the definition  
 (6) Average thermal input speed at 50% T<sub>2N</sub> and S1

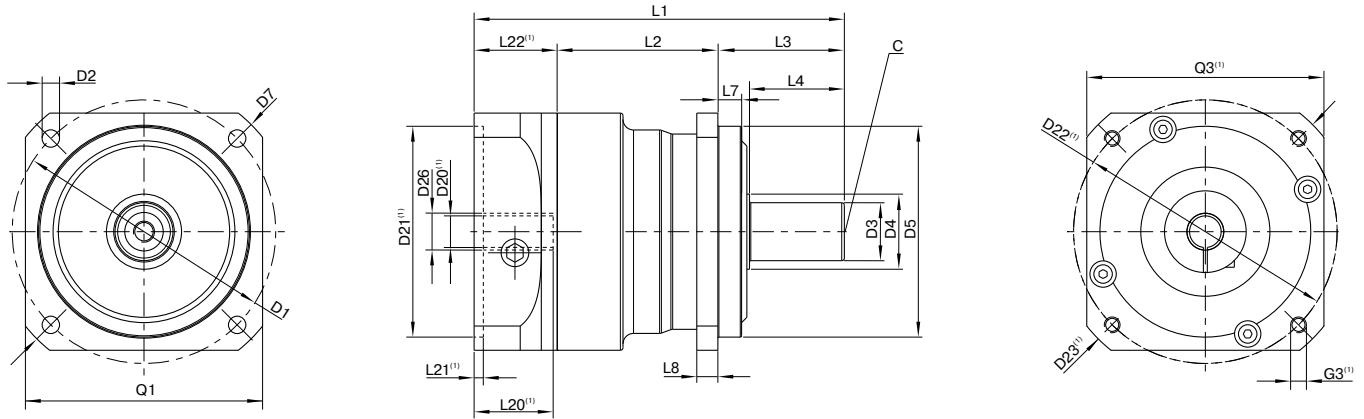

Drawing corresponds to a PSBN090 / 1-stage / smooth output shaft / 14 mm clamping system / motor adaptation – 2-part – round universal flange / B5 flange type motor

<sup>(1)</sup> The dimensions vary with the motor/gearbox flange. The input flange dimensions can be retrieved for each specific motor in Tec Data Finder at [www.neugart.com](http://www.neugart.com)

Geometry <sup>(2)</sup>			PSBN070	PSBN090	PSBN115	PSBN142	p <sup>(3)</sup>	Code
Pitch circle diameter output	D1		70 (2.756)	100 (3.937)	130 (5.118)	165 (6.496)		
Mounting bore output	D2	4x	5.5 (0.217)	6.6 (0.260)	9.0 (0.354)	11.0 (0.433)		
Shaft diameter output	D3	j6	16 (0.630)	22 (0.866)	32 (1.260)	40 (1.575)		
Shaft collar output	D4		23.5 (0.925)	28.5 (1.122)	38.5 (1.516)	48.5 (1.909)		
Centering diameter output	D5	g6	50 (1.969)	80 (3.150)	110 (4.331)	130 (5.118)		
Diagonal dimension output	D7		80 (3.150)	115 (4.528)	148 (5.827)	185 (7.283)		
Flange cross section output	Q1	■	60 (2.362)	90 (3.543)	115 (4.528)	140 (5.512)		
Min. total length	L1		116.5 (4.587)	140.5 (5.531)	182.5 (7.185)	247.5 (9.744)	1	
			145 (5.709)	162.5 (6.398)	204.5 (8.051)	278.5 (10.965)	2	
Housing length	L2		54 (2.126)	61 (2.402)	74 (2.913)	100.5 (3.957)	1	
			82.5 (3.248)	89 (3.504)	107.5 (4.232)	138.5 (5.453)	2	
Shaft length output	L3		37 (1.457)	48 (1.890)	65 (2.559)	97 (3.819)		
Centering depth output	L7		6 (0.236)	9 (0.354)	4 (0.157)	12 (0.472)		
Flange thickness output	L8		6 (0.236)	8 (0.315)	10 (0.394)	12 (0.472)		
Center hole (DIN 332, type DR)	C		M5x12.5	M8x19	M12x28	M16x36		
Motor shaft diameter j6/k6	D20		More information on page 155/156					
Clamping system diameter input	D26		More information on page 155/156					
Output shaft with feather key (DIN 6885-1)			A 5x5x25	A 6x6x28	A 10x8x50	A 12x8x65		
Feather key width (DIN 6885-1)	B1		5 (0.197)	6 (0.236)	10 (0.394)	12 (0.472)		<b>A</b>
Shaft height including feather key (DIN 6885-1)	H1		18 (0.709)	24.5 (0.965)	35 (1.378)	43 (1.693)		
Shaft length from shoulder	L4		28 (1.102)	36 (1.417)	58 (2.283)	82 (3.228)		
Feather key length	L5		25 (0.984)	28 (1.102)	50 (1.969)	65 (2.559)		
Distance from shaft end	L6		2 (0.079)	4 (0.157)	4 (0.157)	8 (0.315)		
Smooth output shaft								
Shaft length from shoulder	L4		28 (1.102)	36 (1.417)	58 (2.283)	82 (3.228)		<b>B</b>

<sup>(2)</sup> Dimensions in mm

<sup>(3)</sup> Number of stages