

# PLQE

**Das einfach zu montierende Planetengetriebe, das bei geringer Wärmeentwicklung hohe Kräfte aufnimmt**

Unser **PLQE** ist unkompliziert und leistungsstark. Es kann ohne Zwischenflansch direkt mit Ihrer Anlage verbunden werden. Die größeren Rillenkugellager am Abtrieb ermöglichen die Aufnahme höherer Axial- und Radialkräfte. Dank seines guten Wirkungsgrades arbeitet es auch in anspruchsvollen Produktionszyklen immer zuverlässig.

**The easy to install planetary gearbox absorbs high forces with low heat generation**

Our **PLQE** is uncomplicated and powerful. It can be connected directly to your installation without the need for an intermediate flange. The larger deep groove ball bearings on the output allow higher axial and radial forces to be absorbed. Thanks to its favorable efficiency, this means that it always operates reliably even when production cycles are demanding.

Nenn-Abtriebsdrehmoment  
Nominal output torque **15 - 260 Nm**



Radialkraft  
Radial force **900 - 2950 N**

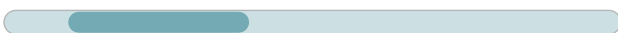

Axialkraft  
Axial force **1000 - 2500 N**



Verdrehspiel  
Torsional backlash **7 - 15 arcmin**



Schutzart  
Protection class **IP54**



Baugrößen  
Frame sizes

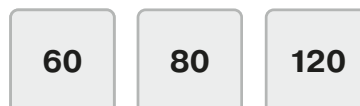

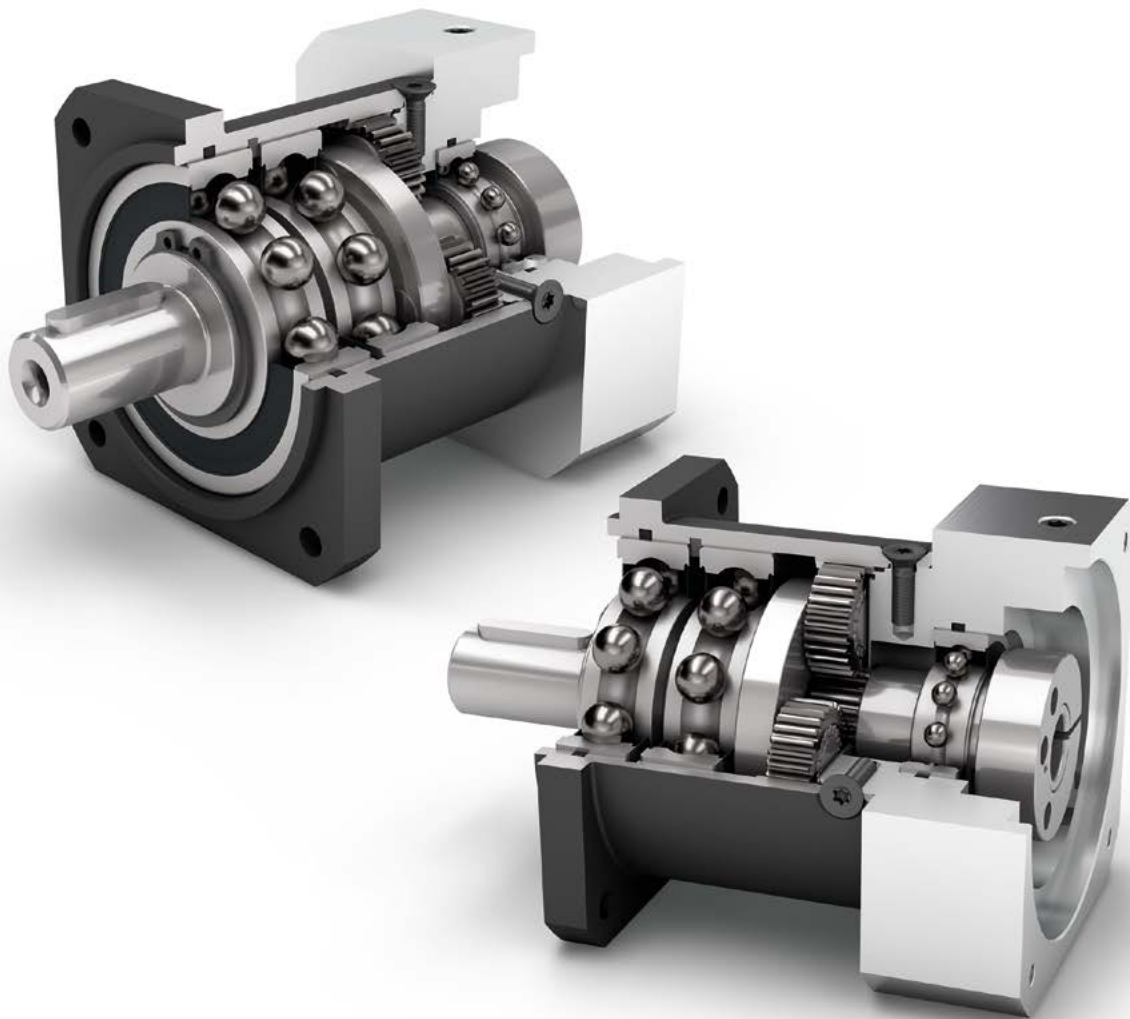

Economy Line  
Economy Line



Drehrichtung gleichsinnig  
Equidirectional rotation



Quadratischer Abtriebsflansch  
Square type output flange

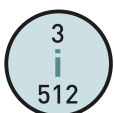

Hohe Übersetzungsvielfalt  $i=3$  bis  $i=512$   
High ratio variety  $i=3$  up to  $i=512$

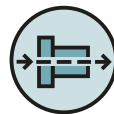

Koaxialgetriebe  
Coaxial gearbox



Geradverzahnt  
Spur gear



Verstärkte Rillenkugellager  
Reinforced deep groove ball bearings



Planetenträger in Scheibenausführung  
Planet carrier in disc design

Detaillierte Erläuterungen der technischen Features ab Seite 171.  
Detailed explanations of the technical features starting on page 171.

PLQE

Code	Getriebekennwerte	Gearbox characteristics			PLQE060	PLQE080	PLQE120	p <sup>(1)</sup>
	Lebensdauer (L <sub>10h</sub> )	Service life (L <sub>10h</sub> )	t <sub>L</sub>	h	30.000			
	Wirkungsgrad bei Vollast <sup>(2)</sup>	Efficiency at full load <sup>(2)</sup>	η	%	98			1
97					2			
92					3			
	Betriebstemperatur min.	Min. operating temperature	T <sub>min</sub>	°C	-25			
	Betriebstemperatur max.	Max. operating temperature	T <sub>max</sub>		90			
	Schutzart	Protection class		IP54				
<b>S</b>	Standard Schmierung	Standard lubrication		Fett (lebensdauergeschmiert) / Grease (lifetime lubrication)				
<b>F</b>	Lebensmitteltaugliche Schmierung	Food grade lubrication		Fett (lebensdauergeschmiert) / Grease (lifetime lubrication)				
<b>L</b>	Tieftemperatur Schmierung <sup>(3)</sup>	Low temperature lubrication <sup>(3)</sup>		Fett (lebensdauergeschmiert) / Grease (lifetime lubrication)				
	Einbaulage	Installation position		Beliebig / Any				
<b>S</b>	Standard Verdrehspiel	Standard backlash	j <sub>t</sub>	arcmin	< 10	< 7	< 7	1
					< 12	< 9	< 9	2
					< 15	< 11	< 11	3
	Verdrehsteifigkeit <sup>(2)</sup>	Torsional stiffness <sup>(2)</sup>	c <sub>G</sub>	Nm / arcmin	2,8 - 4,0	8,5 - 12,6	14,0 - 18,5	1
					3,3 - 4,1	9,4 - 13,3	15,6 - 19,0	2
					3,3 - 4,1	9,4 - 13,4	15,6 - 19,0	3
	Getriebegewicht <sup>(2)</sup>	Gearbox weight <sup>(2)</sup>	m <sub>G</sub>	kg	1,1	2,7 - 2,9	6,4 - 6,5	1
					1,3	3,4 - 3,5	8,1 - 8,3	2
					1,5	3,9 - 4,0	9,9 - 10,1	3
<b>S</b>	Standard Oberfläche	Standard surface			Gehäuse: Stahl – wärmebehandelt und nachoxidiert (schwarz) Housing: Steel – heat-treated and post-oxidized (black)			
	Laufgeräusch <sup>(4)</sup>	Running noise <sup>(4)</sup>	Q <sub>G</sub>	dB(A)	58	60	65	
	Max. Biegemoment bezogen auf den Getriebeantriebsflansch <sup>(5)</sup>	Max. bending moment based on the gearbox input flange <sup>(5)</sup>	M <sub>b</sub>	Nm	12	16	40	

Abtriebswellenbelastungen	Output shaft loads			PLQE060	PLQE080	PLQE120	p <sup>(1)</sup>
Radialkraft für 20.000 h <sup>(6)(7)</sup>	Radial force for 20,000 h <sup>(6)(7)</sup>	F <sub>r20.000 h</sub>	N	900	2050	2950	
Axialkraft für 20.000 h <sup>(6)(7)</sup>	Axial force for 20,000 h <sup>(6)(7)</sup>	F <sub>a20.000 h</sub>		1000	2500	2500	
Radialkraft für 30.000 h <sup>(6)(7)</sup>	Radial force for 30,000 h <sup>(6)(7)</sup>	F <sub>r30.000 h</sub>		700	1700	2400	
Axialkraft für 30.000 h <sup>(6)(7)</sup>	Axial force for 30,000 h <sup>(6)(7)</sup>	F <sub>a30.000 h</sub>		800	2000	2100	
Maximale Radialkraft <sup>(7)(8)</sup>	Maximum radial force <sup>(7)(8)</sup>	F <sub>r Stat</sub>		1500	2500	4000	
Maximale Axialkraft <sup>(7)(8)</sup>	Maximum axial force <sup>(7)(8)</sup>	F <sub>a Stat</sub>		1950	3800	3800	
Kippmoment für 20.000 h <sup>(6)(8)</sup>	Tilting moment for 20,000 h <sup>(6)(8)</sup>	M <sub>K20.000 h</sub>	Nm	37	101	232	
Kippmoment für 30.000 h <sup>(6)(8)</sup>	Tilting moment for 30,000 h <sup>(6)(8)</sup>	M <sub>K30.000 h</sub>		29	84	188	

Trägheitsmoment	Moment of inertia			PLQE060	PLQE080	PLQE120	p <sup>(1)</sup>
Massenträgheitsmoment <sup>(2)</sup>	Mass moment of inertia <sup>(2)</sup>	J	kgcm <sup>2</sup>	0,066 - 0,142	0,371 - 0,783	1,381 - 2,393	1
				0,066 - 0,123	0,366 - 0,625	1,414 - 2,292	2
				0,066 - 0,076	0,365 - 0,590	1,413 - 2,196	3

(1) Anzahl Getriebestufen  
 (2) Die übersetzungsabhängigen Werte sind im Tec Data Finder abrufbar – www.neugart.com  
 (3) T<sub>min</sub> = -40°C. Optimale Betriebstemperatur max. 50°C  
 (4) Schalldruckpegel in 1 m Abstand; gemessen bei einer Antriebsdrehzahl von n<sub>1</sub>=3000 min<sup>-1</sup> ohne Last; i=5  
 (5) Max. Motorgewicht\* in kg = 0,2 x M<sub>o</sub> / Motorlänge in m  
 \* bei symmetrischer Motorgewichtsverteilung  
 \* bei horizontaler und stationärer Einbaulage  
 (6) Die Angaben beziehen sich auf eine Abtriebswellendrehzahl von n<sub>2</sub>=100 min<sup>-1</sup>  
 (7) Bezogen auf die Mitte der Abtriebswelle  
 (8) Abweichende (teilweise höhere) Werte bei Änderungen von T<sub>2N</sub>, F<sub>r</sub>, F<sub>a</sub>, sowie Zyklus und Lagerlebensdauer. Applikationsspezifische Auslegung mit NCP – www.neugart.com

(1) Number of stages  
 (2) The ratio-dependent values can be retrieved in Tec Data Finder – www.neugart.com  
 (3) T<sub>min</sub> = -40°C. Optimal operating temperature max. 50°C  
 (4) Sound pressure level from 1 m, measured on input running at n<sub>1</sub>=3000 rpm no load; i=5  
 (5) Max. motor weight\* in kg = 0.2 x M<sub>o</sub> / motor length in m  
 \* with symmetrically distributed motor weight  
 \* with horizontal and stationary mounting  
 (6) These values are based on an output shaft speed of n<sub>2</sub>=100 rpm  
 (7) Based on center of output shaft  
 (8) Other (sometimes higher) values following changes to T<sub>2N</sub>, F<sub>r</sub>, F<sub>a</sub>, cycle, and service life of bearing. Application specific configuration with NCP – www.neugart.com

Abtriebsdrehmomente	Output torques			PLQE060	PLQE080	PLQE120	i <sup>(1)</sup>	p <sup>(2)</sup>
Nenn-Abtriebsdrehmoment <sup>(3)(4)</sup>	Nominal output torque <sup>(3)(4)</sup>	T <sub>2N</sub>	Nm	28	85	115	3	1
				38	115	155	4	
				40	110	195	5	
				25	65	135	7	
				18	50	120	8	
				15	38	95	10	
				44	130	210	9	2
				44	120	260	12	
				44	110	230	15	
				44	120	260	16	
				44	120	260	20	
				40	110	230	25	
				44	120	260	32	3
				40	110	230	40	
				18	50	120	64	
				44	110	260	60	
				44	120	260	80	
				44	120	260	100	
				44	110	230	120	3
				44	120	260	160	
				40	110	230	200	
44	120	260	256					
40	110	230	320					
18	50	120	512					
Max. Abtriebsdrehmoment <sup>(4)(5)</sup>	Max. output torque <sup>(4)(5)</sup>	T <sub>2max</sub>	Nm	45	136	184	3	1
				61	184	248	4	
				64	176	312	5	
				40	104	216	7	
				29	80	192	8	
				24	61	152	10	
				70	208	336	9	2
				70	192	416	12	
				70	176	368	15	
				70	192	416	16	
				70	192	416	20	
				64	176	368	25	
				70	192	416	32	3
				64	176	368	40	
				29	80	192	64	
				70	176	416	60	
				70	192	416	80	
				70	192	416	100	
				70	176	368	120	3
				70	192	416	160	
				64	176	368	200	
70	192	416	256					
64	176	368	320					
29	80	192	512					

PLQE

(1) Übersetzungen (i=n<sub>1</sub>/n<sub>2</sub>)  
 (2) Anzahl Getriebestufen  
 (3) Applikationsspezifische Auslegung mit NCP – www.neugart.com  
 (4) Werte bei Passfeder (Code „A“): für schwelende Belastung  
 (5) Zulässig für 30.000 Umdrehungen der Abtriebswelle; siehe Seite 164

(1) Ratios (i=n<sub>1</sub>/n<sub>2</sub>)  
 (2) Number of stages  
 (3) Application specific configuration with NCP – www.neugart.com  
 (4) Values for feather key (code "A"): for repeated load  
 (5) 30,000 rotations of the output shaft permitted; see page 165

PLQE

Abtriebsdrehmomente	Output torques			PLQE060	PLQE080	PLQE120	i <sup>(1)</sup>	p <sup>(2)</sup>
Not-Aus Drehmoment <sup>(3)</sup>	Emergency stop torque <sup>(3)</sup>	T <sub>2Stop</sub>	Nm	66	180	390	3	1
				88	240	520	4	
				80	220	500	5	
				80	178	340	7	
				80	190	380	8	
				80	200	480	10	
				88	260	500	9	2
				88	240	520	12	
				88	220	500	15	
				88	240	520	16	
				88	240	520	20	
				80	220	500	25	
				88	240	520	32	3
				80	220	500	40	
				80	190	380	64	
				88	220	520	60	
				88	240	520	80	
				88	240	520	100	
				88	220	500	120	3
				88	240	520	160	
				80	220	500	200	
				88	240	520	256	
				80	220	500	320	
				80	190	380	512	

Antriebsdrehzahlen	Input speeds			PLQE060	PLQE080	PLQE120	i <sup>(1)</sup>	p <sup>(2)</sup>
Mittlere thermische Antriebsdrehzahl bei T <sub>2N</sub> und S1 <sup>(4)(5)</sup>	Average thermal input speed at T <sub>2N</sub> and S1 <sup>(4)(5)</sup>	n <sub>1N</sub>	min <sup>-1</sup>	4500 <sup>(6)</sup>	3400 <sup>(6)</sup>	3400 <sup>(6)</sup>	3	1
				4500 <sup>(6)</sup>	3450 <sup>(6)</sup>	3500 <sup>(6)</sup>	4	
				4500	4000 <sup>(6)</sup>	3500 <sup>(6)</sup>	5	
				4500	4000	3500	7	
				4500	4000	3500	8	
				4500	4000	3500	10	
				4500	4000 <sup>(6)</sup>	3500 <sup>(6)</sup>	9	2
				4500	4000 <sup>(6)</sup>	3500 <sup>(6)</sup>	12	
				4500	4000	3500 <sup>(6)</sup>	15	
				4500	4000	3500 <sup>(6)</sup>	16	
				4500	4000	3500	20	
				4500	4000	3500	25	
				4500	4000	3500	32	3
				4500	4000	3500	40	
				4500	4000	3500	64	
				4500	4000	3500	60	
				4500	4000	3500	80	
				4500	4000	3500	100	
				4500	4000	3500	120	3
				4500	4000	3500	160	
				4500	4000	3500	200	
				4500	4000	3500	256	
				4500	4000	3500	320	
				4500	4000	3500	512	
Max. mechanische Antriebsdrehzahl <sup>(4)</sup>	Max. mechanical input speed <sup>(4)</sup>	n <sub>1Limit</sub>	min <sup>-1</sup>	13000	7000	6500		

<sup>(1)</sup> Übersetzungen (i=n<sub>1</sub>/n<sub>2</sub>)

<sup>(2)</sup> Anzahl Getriebestufen

<sup>(3)</sup> 1000-mal zulässig

<sup>(4)</sup> Applikationsspezifische Auslegung der Drehzahlen mit NCP – www.neugart.com

<sup>(5)</sup> Definition siehe Seite 164

<sup>(6)</sup> Mittlere thermische Antriebsdrehzahl bei 50% T<sub>2N</sub> und S1

<sup>(1)</sup> Ratios (i=n<sub>1</sub>/n<sub>2</sub>)

<sup>(2)</sup> Number of stages

<sup>(3)</sup> Permitted 1000 times

<sup>(4)</sup> Application-specific speed configurations with NCP – www.neugart.com

<sup>(5)</sup> See page 165 for the definition

<sup>(6)</sup> Average thermal input speed at 50% T<sub>2N</sub> and S1

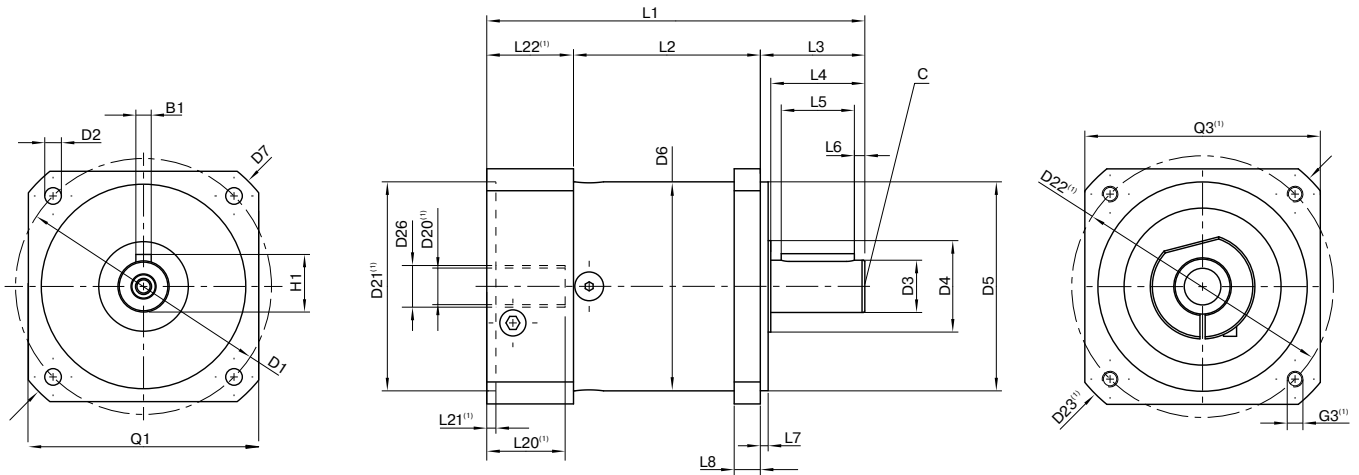

Darstellung entspricht einem PLQE080 / 1-stufig / Abtriebswelle mit Passfeder / 19 mm Spannsystem / Motoranpassung – einteilig / B5 Flanschtyp Motor  
 Drawing corresponds to a PLQE080 / 1-stage / output shaft with feather key / 19 mm clamping system / motor adaptation – one part / B5 flange type motor

<sup>(1)</sup> Die Maße variieren je nach Motor-/Getriebeflansch. Die motorspezifischen Antriebsflansch-Geometrien können im Tec Data Finder für jeden Motor gezielt abgerufen werden - [www.neugart.com](http://www.neugart.com)  
<sup>(1)</sup> The dimensions vary with the motor/gearbox flange. The input flange dimensions can be retrieved for each specific motor in Tec Data Finder at [www.neugart.com](http://www.neugart.com)

Geometrie <sup>(2)</sup>	Geometry <sup>(2)</sup>			PLQE060	PLQE080	PLQE120	p <sup>(3)</sup>	Code
Lochkreisdurchmesser Abtrieb	Pitch circle diameter output	D1		75	100	130		
Montagebohrung Abtrieb	Mounting bore output	D2	4x	5,5	6,5	8,5		
Wellendurchmesser Abtrieb	Shaft diameter output	D3	h7	16	20	25		
Wellenansatz Abtrieb	Shaft collar output	D4		20	35	35		
Zentrierbund Ø Abtrieb	Centering Ø output	D5	h7	60	80	110		
Gehäusedurchmesser	Housing diameter	D6		60	80	115		
Diagonalmaß Abtrieb	Diagonal dimension output	D7		92	116	145		
Flanschquerschnitt Abtrieb	Flange cross section output	Q1	■	70	90	115		
Min. Gesamtlänge	Min. total length	L1		111	145	201,5	1	
				123,5	162,5	229,5	2	
				136	180	257	3	
Gehäuselänge	Housing length	L2		55	71	99	1	
				67,5	89	127	2	
				80,5	106,5	154,5	3	
Wellenlänge Abtrieb	Shaft length output	L3		32	40	55		
Zentrierbundtiefe Abtrieb	Centering depth output	L7		3	3	4		
Flanschdicke Abtrieb	Flange thickness output	L8		10	10	15		
Durchmesser Motorwelle j6/k6	Motor shaft diameter j6/k6	D20		Weitere Informationen auf Seite 161/162 More information on page 161/162				
Ø Spannsystem am Antrieb	Clamping system Ø input	D26		Weitere Informationen auf Seite 161/162 More information on page 161/162				
Abtriebswelle mit Passfeder (DIN 6885-1)	Output shaft with feather key (DIN 6885-1)			A 5x5x20	A 6x6x28	A 8x7x40		A
Passfederbreite (DIN 6885-1)	Feather key width (DIN 6885-1)	B1		5	6	8		
Wellenhöhe inklusive Passfeder (DIN 6885-1)	Shaft height including feather key (DIN 6885-1)	H1		18	22,5	28		
Wellenlänge bis Bund	Shaft length from shoulder	L4		28	36	50		
Passfederlänge	Feather key length	L5		20	28	40		
Abstand vom Wellenende	Distance from shaft end	L6		4	4	5		
Zentrierbohrung (DIN 332, Form DR)	Center hole (DIN 332, type DR)	C		M5x12,5	M6x16	M10x22		
Glatte Abtriebswelle	Smooth output shaft							B
Wellenlänge bis Bund	Shaft length from shoulder	L4		28	36	50		

<sup>(2)</sup> Maße in mm  
<sup>(3)</sup> Anzahl Getriebestufen

<sup>(2)</sup> Dimensions in mm  
<sup>(3)</sup> Number of stages