



# WPLPE

经济型直角行星减速机，适用于承载力很大的工况中  
安装灵活，终生润滑，免维护

**WPLPE**是我们的经济型系列中广受欢迎的直角型减速机：它能节约空间，同时性能强大、价格合理。您可以把您的驱动元件直接安装到输出轴上，后者超强的深沟球轴承可以承受较高的径向力和轴向力。

The economical right angle planetary gearbox for particularly high forces – flexible installation options and lifetime lubrication

The **WPLPE** is the sought-after angle solution from our Economy range: space-saving yet powerful at an attractive price. You attach your drive elements directly to the output shaft, which can also withstand high radial forces thanks to extra-strong deep groove ball bearings.

#### 额定扭矩

Nominal output torque **5 - 195 Nm**



#### 径向力

Radial force **800 - 2500 N**



#### 轴向力

Axial force **1000 - 4000 N**



#### 回程间隙

Torsional backlash **11 - 25 arcmin**



#### 防护等级

Protection class **IP54**



#### 结构尺寸

Frame sizes

50

70

90

120

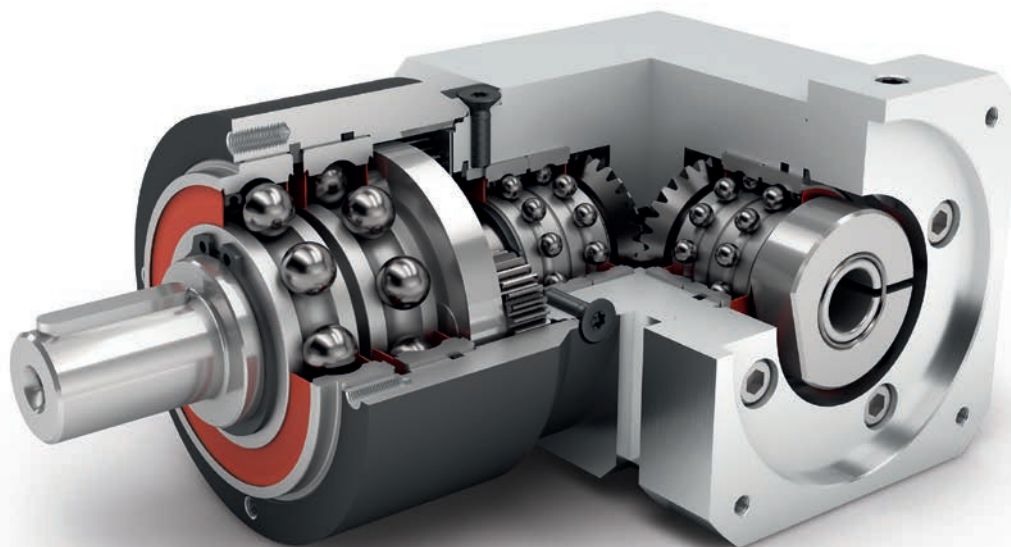

WPLPE



经济型  
Economy Line



直角型减速机  
Right angle gearbox



旋转方向 同方向  
Equidirectional rotation



直齿  
Spur gear



锥齿轮 直角型  
Bevel gear right angle stage

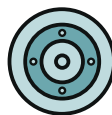

圆形输出法兰  
Round type output flange



增强深沟球轴承  
Reinforced deep groove ball bearings



行星齿轮架  
Planet carrier in disc design

技术特点的详细解释，请从第171页读起。  
Detailed explanations of the technical features starting on page 171.

Code	减速机参数	Gearbox characteristics			WPLPE050	WPLPE070	WPLPE090	WPLPE120	p <sup>(1)</sup>	
	使用寿命 (L <sub>10h</sub> )	Service life (L <sub>10h</sub> )	t <sub>L</sub>	h	20.000					
	T <sub>2N</sub> × 0,88 时的使用寿命	Service life at T <sub>2N</sub> × 0,88			30.000					
	满载时效率 <sup>(2)</sup>	Efficiency at full load <sup>(2)</sup>	η	%	95				1	
	最低工作温度	Min. operating temperature	T <sub>min</sub>	°C	-25					
	最高工作温度	Max. operating temperature	T <sub>max</sub>		90					
	防护等级	Protection class					IP54			
S	标准润滑	Standard lubrication					润滑脂 (终生润滑) / Grease (lifetime lubrication)			
F	食品级润滑	Food grade lubrication					润滑脂 (终生润滑) / Grease (lifetime lubrication)			
L	低温润滑 <sup>(3)</sup>	Low temperature lubrication <sup>(3)</sup>					润滑脂 (终生润滑) / Grease (lifetime lubrication)			
	安装位置	Installation position					任意 / Any			
S	标准回程间隙	Standard backlash	j <sub>t</sub>	arcmin	< 21	< 16	< 13	< 11	1	
					< 25	< 18	< 15	< 13	2	
	抗扭刚度 <sup>(2)</sup>	Torsional stiffness <sup>(2)</sup>	c <sub>G</sub>	Nm / arcmin	0,5 - 0,8	2,2 - 4,1	4,7 - 10,8	13,1 - 28,0	1	
					0,7 - 1,0	3,3 - 5,3	9,0 - 14,1	19,5 - 38,5	2	
	减速机重量 <sup>(2)</sup>	Gearbox weight <sup>(2)</sup>	m <sub>G</sub>	kg	0,8	2,1 - 2,2	4,8 - 4,9	11,5 - 11,6	1	
					1,0 - 1,3	2,4 - 2,6	5,5 - 5,6	13,4 - 13,7	2	
S	标准的箱体表面	Standard surface					箱体: 钢 - 热处理后氧化 (黑色) Housing: Steel - heat-treated and post-oxidized (black)			
	运行噪音 <sup>(4)</sup>	Running noise <sup>(4)</sup>	Q <sub>G</sub>	dB(A)	68	70	73	75		
	基于减速机输入法兰的最大弯矩 <sup>(5)</sup>	Max. bending moment based on the gearbox input flange <sup>(5)</sup>	M <sub>b</sub>	Nm	2	5	10,5	26		

输出轴载荷	Output shaft loads			WPLPE050	WPLPE070	WPLPE090	WPLPE120	p <sup>(1)</sup>
20,000 h 的径向力 <sup>(6)(7)</sup>	Radial force for 20,000 h <sup>(6)(7)</sup>	F <sub>r20.000h</sub>	N	800	1050	1900	2500	
20,000 h 的轴向力 <sup>(6)(7)</sup>	Axial force for 20,000 h <sup>(6)(7)</sup>	F <sub>a20.000h</sub>		1000	1350	2000	4000	
30,000 h 的径向力 <sup>(6)(7)</sup>	Radial force for 30,000 h <sup>(6)(7)</sup>	F <sub>r30.000h</sub>		700	900	1700	2150	
30,000 h 的轴向力 <sup>(6)(7)</sup>	Axial force for 30,000 h <sup>(6)(7)</sup>	F <sub>a30.000h</sub>		800	1000	1500	3000	
最大径向力 <sup>(7)(8)</sup>	Maximum radial force <sup>(7)(8)</sup>	F <sub>r Stat</sub>		1300	1650	3100	4000	
最大轴向力 <sup>(7)(8)</sup>	Maximum axial force <sup>(7)(8)</sup>	F <sub>a Stat</sub>		1000	2100	3800	5900	
20,000 h 倾斜力矩 <sup>(6)(8)</sup>	Tilting moment for 20,000 h <sup>(6)(8)</sup>	M <sub>K20.000h</sub>	Nm	26	42	99	168	
30,000 h 倾斜力矩 <sup>(6)(8)</sup>	Tilting moment for 30,000 h <sup>(6)(8)</sup>	M <sub>K30.000h</sub>		22	36	89	144	

转动惯量	Moment of inertia			WPLPE050	WPLPE070	WPLPE090	WPLPE120	p <sup>(1)</sup>
转动惯量 <sup>(2)</sup>	Mass moment of inertia <sup>(2)</sup>	J	kgcm <sup>2</sup>	0,032 - 0,052	0,213 - 0,324	0,877 - 1,361	2,686 - 4,073	1
				0,031 - 0,048	0,212 - 0,321	0,859 - 1,197	2,643 - 3,643	2

(1) 减速机级数  
 (2) 传动比相关的数值可在 Tec Data Finder 中检索 - www.neugart.com  
 (3) T<sub>min</sub> = -40°C. 理想运行温度最高为 50°C  
 (4) 距离减速机 1 m 时; 在输入转速为 n<sub>1</sub>=3000 min<sup>-1</sup> 且无负荷时测得; i=5  
 (5) 最大电机重量\* (单位: kg) = 0.2 × M<sub>b</sub> / 电机长度 (单位: m)  
 \* 电机重量对称分布  
 \* 水平和固定的安装位置  
 (6) 数据以 n<sub>2</sub>=100 min<sup>-1</sup> 的输出轴转速为准。  
 (7) 以输出轴中心为准  
 (8) 更改 T<sub>2N</sub>, F<sub>r</sub>, F<sub>a</sub> 以及周期和轴承使用寿命时, 数值存在偏差 (部分较高)。利用 NCP 针对应用进行专门设计 - www.neugart.com

(1) Number of stages  
 (2) The ratio-dependent values can be retrieved in Tec Data Finder - www.neugart.com  
 (3) T<sub>min</sub> = -40°C. Optimal operating temperature max. 50°C  
 (4) Sound pressure level from 1 m, measured on input running at n<sub>1</sub>=3000 rpm no load; i=5  
 (5) Max. motor weight\* in kg = 0.2 × M<sub>b</sub> / motor length in m  
 \* with symmetrically distributed motor weight  
 \* with horizontal and stationary mounting  
 (6) These values are based on an output shaft speed of n<sub>2</sub>=100 rpm  
 (7) Based on center of output shaft  
 (8) Other (sometimes higher) values following changes to T<sub>2N</sub>, F<sub>r</sub>, F<sub>a</sub>, cycle, and service life of bearing. Application specific configuration with NCP - www.neugart.com

输出扭矩	Output torques			WPLPE050	WPLPE070	WPLPE090	WPLPE120	i <sup>(1)</sup>	p <sup>(2)</sup>		
额定输出扭矩 <sup>(3)(4)</sup>	Nominal output torque <sup>(3)(4)</sup>	T <sub>2N</sub>	Nm	4,5	14	40 <sup>(5)</sup>	80 <sup>(5)</sup>	3	1		
				6	19	53 <sup>(5)</sup>	105 <sup>(5)</sup>	4			
				7,5	24	67 <sup>(5)</sup>	130 <sup>(5)</sup>	5			
				8,5	25	65	135	7			
				6	18	50	120	8			
				5	15	38	95	10			
				12	33	97	157	9			
				15	33	90	195	12			
						13	33	82	172	15	2
						15	33	90	195	16	
						15	33	90	195	20	
						13	30	82	172	25	
						15	33	90	195	32	
						13	30	82	172	40	
						7,5	18	50	120	64	
						5	15	38	95	100	
最大输出扭矩 <sup>(4)(6)</sup>	Max. output torque <sup>(4)(6)</sup>	T <sub>2max</sub>	Nm	7	22	64	128	3	1		
				10	30	85	168	4			
				12	38	107	208	5			
				13,5	40	104	216	7			
				10	29	80	192	8			
				8	24	61	152	10			
				19	53	155	251	9			
				24	53	144	312	12			
						21	53	131	275	15	2
						24	53	144	312	16	
						24	53	144	312	20	
						21	48	131	275	25	
						24	53	144	312	32	
						21	48	131	275	40	
						12	29	80	192	64	
						8	24	61	152	100	

WPLPE

<sup>(1)</sup> 传动比 (i=n<sub>1</sub>/n<sub>2</sub>)  
<sup>(2)</sup> 减速机级数  
<sup>(3)</sup> 利用 NCP 针对应用进行专门设计 – www.neugart.com  
<sup>(4)</sup> 平键 (代码 "A")时的数值; 针对交变载荷  
<sup>(5)</sup> T<sub>2N</sub> 作用时 寿命不是10.000 h  
<sup>(6)</sup> 允许输出轴转动30.000转; 参见第 164 页

<sup>(1)</sup> Ratios (i=n<sub>1</sub>/n<sub>2</sub>)  
<sup>(2)</sup> Number of stages  
<sup>(3)</sup> Application specific configuration with NCP – www.neugart.com  
<sup>(4)</sup> Values for feather key (code "A"): for repeated load  
<sup>(5)</sup> Different service life: 10,000 h at T<sub>2N</sub>  
<sup>(6)</sup> 30,000 rotations of the output shaft permitted; see page 165

输出扭矩	Output torques			WPLPE050	WPLPE070	WPLPE090	WPLPE120	i <sup>(1)</sup>	p <sup>(2)</sup>
急停扭矩 <sup>(3)</sup>	Emergency stop torque <sup>(3)</sup>	T <sub>2Stop</sub>	Nm	22,5	66	180	360	3	1
				28	86	240	474	4	
				35	80	220	500	5	
				26	80	178	340	7	
				27	80	190	380	8	
				25	70	170	430	10	
			2	33	88	260	500	9	
				40	88	240	520	12	
				36	88	220	500	15	
				40	88	240	520	16	
				40	88	240	520	20	
				36	80	220	500	25	
				40	88	240	520	32	
				36	80	220	500	40	
				27	80	190	380	64	
				27	80	170	430	100	

输入转速	Input speeds			WPLPE050	WPLPE070	WPLPE090	WPLPE120	i <sup>(1)</sup>	p <sup>(2)</sup>					
T <sub>2N</sub> 和 S1 时的平均热输入转速 <sup>(4)(5)</sup>	Average thermal input speed at T <sub>2N</sub> and S1 <sup>(4)(5)</sup>	n <sub>1N</sub>	min <sup>-1</sup>	5000	4200 <sup>(6)</sup>	3000 <sup>(6)</sup>	2350 <sup>(6)</sup>	3	1					
				5000	4500 <sup>(6)</sup>	3150 <sup>(6)</sup>	2450 <sup>(6)</sup>	4						
				5000	4500 <sup>(6)</sup>	3250 <sup>(6)</sup>	2600 <sup>(6)</sup>	5						
				5000	4500 <sup>(6)</sup>	3950 <sup>(6)</sup>	3100 <sup>(6)</sup>	7						
				5000	4500	4000 <sup>(6)</sup>	3450 <sup>(6)</sup>	8						
				5000	4500	4000	3500 <sup>(6)</sup>	10						
				2	5000	4500 <sup>(6)</sup>	3500 <sup>(6)</sup>	2950 <sup>(6)</sup>	9					
					5000	4500	4000 <sup>(6)</sup>	3050 <sup>(6)</sup>	12					
					5000	4500	4000 <sup>(6)</sup>	3450 <sup>(6)</sup>	15					
					5000	4500	4000 <sup>(6)</sup>	3450 <sup>(6)</sup>	16					
					5000	4500	4000 <sup>(6)</sup>	3500 <sup>(6)</sup>	20					
					5000	4500	4000	3500 <sup>(6)</sup>	25					
					5000	4500	4000	3500	32					
					5000	4500	4000	3500	40					
					5000	4500	4000	3500	64					
					5000	4500	4000	3500	100					
					最高机械输入转速 <sup>(4)</sup>	Max. mechanical input speed <sup>(4)</sup>	n <sub>1Limit</sub>	min <sup>-1</sup>	18000	13000	7000	6500		

<sup>(1)</sup> 传动比 (i=n<sub>1</sub>/n<sub>2</sub>)

<sup>(2)</sup> 减速级数

<sup>(3)</sup> 允许 1000 次

<sup>(4)</sup> 利用 NCP 针对应用设计转速 – www.neugart.com

<sup>(5)</sup> 定义请参见第 164 页

<sup>(6)</sup> 在 50% T<sub>2N</sub> 输出和 S1 模式下的平均热输入转速

<sup>(1)</sup> Ratios (i=n<sub>1</sub>/n<sub>2</sub>)

<sup>(2)</sup> Number of stages

<sup>(3)</sup> Permitted 1000 times

<sup>(4)</sup> Application-specific speed configurations with NCP – www.neugart.com

<sup>(5)</sup> See page 165 for the definition

<sup>(6)</sup> Average thermal input speed at 50% T<sub>2N</sub> and S1

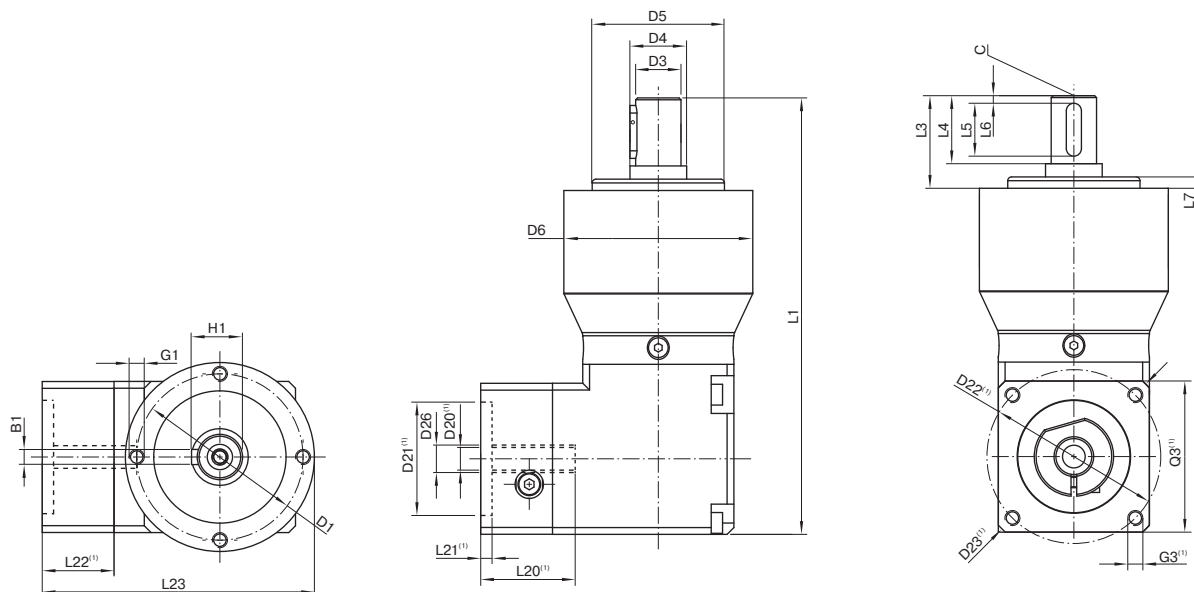

图示为带平键的 WPLPE090 / 1 级 / 附带平键的输出轴 / 19 mm 锁紧系统 / 适配电机法兰 - 2 件式 - 正方形通用法兰 / B5 电机法兰类型  
 Drawing corresponds to a WPLPE090 / 1-stage / output shaft with feather key / 19 mm clamping system / motor adaptation - 2-part - square universal flange / B5 flange type motor

(1) 具体尺寸视电机/减速机法兰而定。可以在 [www.neugart.com](http://www.neugart.com) 下 Tec Data Finder 中针对每个电机适配电机特有的输入法兰几何尺寸。  
 (1) The dimensions vary with the motor/gearbox flange. The input flange dimensions can be retrieved for each specific motor in Tec Data Finder at [www.neugart.com](http://www.neugart.com)

几何尺寸 <sup>(2)</sup>	Geometry <sup>(2)</sup>			WPLPE050	WPLPE070	WPLPE090	WPLPE120	p <sup>(3)</sup>	Code
输出端安装孔节圆直径	Pitch circle diameter output	D1		44	62	80	108		
输出轴直径	Shaft diameter output	D3	k7	12	16	22	32		
输出轴轴肩直径	Shaft collar output	D4		15	30	35	50		
输出端定位凸台直径	Centering diameter output	D5	h7	35	52	68	90		
箱体直径	Housing diameter	D6		50	70	90	120		
安装螺纹 x 深度	Mounting thread x depth	G1	4x	M4x8	M5x8	M6x9	M8x20		
总长	Total length	L1		115,5	152,5	197,5	265	1	
				128	165,5	215,5	292,5	2	
输出轴轴长	Shaft length output	L3		24,5	36	46	68		
输出端定位凸台深度	Centering depth output	L7		3	3	4	5		
最小总高度	Min. overall height	L23		67	90,5	114,5	148		
电机轴直径j6/k6	Motor shaft diameter j6/k6	D20		更多信息见第 161/162 页 More information on page 161/162					
输入端锁紧系统直径	Clamping system diameter input	D26							
带平键的输出轴 (DIN 6885-1)	Output shaft with feather key (DIN 6885-1)			A 4x4x14	A 5x5x25	A 6x6x32	A 10x8x50		A
平键宽度 (DIN 6885-1)	Feather key width (DIN 6885-1)	B1		4	5	6	10		
含平键在内的轴高 (DIN 6885-1)	Shaft height including feather key (DIN 6885-1)	H1		13,5	18	24,5	35		
到轴肩的距离	Shaft length from shoulder	L4		18	28	36	58		
平键长度	Feather key length	L5		14	25	32	50		
到轴端的距离	Distance from shaft end	L6		2	2	2	4		
中心孔 (DIN 332, DR 形)	Center hole (DIN 332, type DR)	C		M4x10	M5x12,5	M8x19	M12x28		
光滑输出轴	Smooth output shaft								
到轴肩的距离	Shaft length from shoulder	L4		18	28	36	58		B

(2) 所有的尺寸单位为mm  
 (3) 减速机级数

(2) Dimensions in mm  
 (3) Number of stages