

# PLQE

The easy to install planetary gearbox absorbs high forces with low heat generation

Our **PLQE** is uncomplicated and powerful. It can be connected directly to your installation without the need for an intermediate flange. The larger deep groove ball bearings on the output allow higher axial and radial forces to be absorbed. Thanks to its favorable efficiency, this means that it always operates reliably even when production cycles are demanding.

Nominal output torque **15 - 260 Nm**

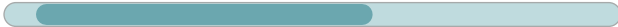

Radial force **900 - 2950 N**



Axial force **1000 - 2500 N**

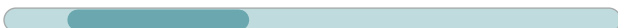

Torsional backlash **7 - 15 arcmin**



Protection class **IP54**



Frame sizes

- 60
- 80
- 120

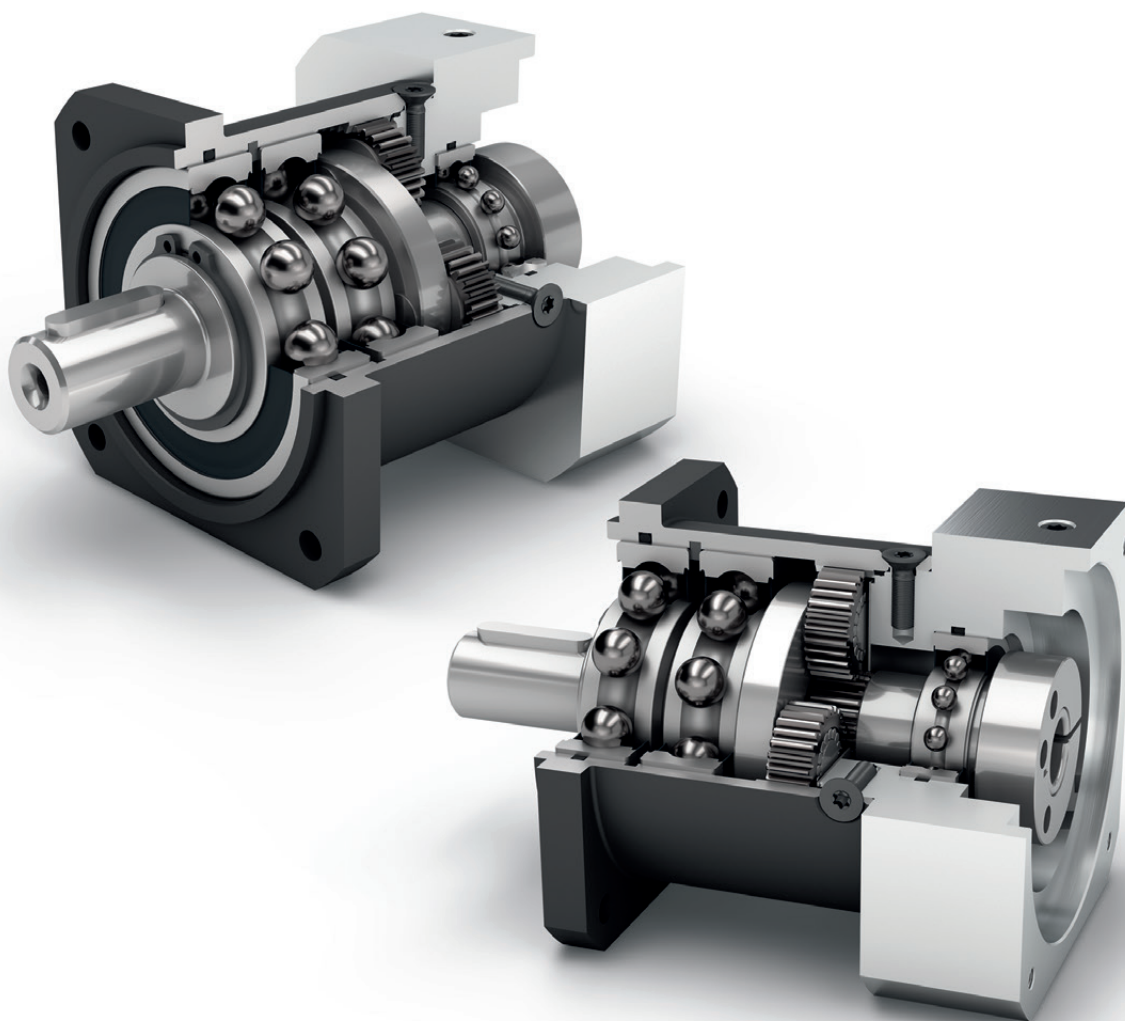

Economy Line

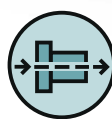

Coaxial gearbox



Equidirectional rotation



Spur gear

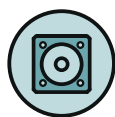

Square type output flange



Reinforced deep groove ball bearings



High ratio variety  $i=3$  up to  $i=512$



Planet carrier in disc design

Detailed explanations of the technical features starting on page 171.

PLQE

Code	Gearbox characteristics			PLQE060	PLQE080	PLQE120	p <sup>(1)</sup>
	Service life (L <sub>10h</sub> )	t <sub>L</sub>	h	30,000			
	Efficiency at full load <sup>(2)</sup>	η	%	98			1
97				2			
92				3			
	Min. operating temperature	T <sub>min</sub>	°C	-25 (-13)			
	Max. operating temperature	T <sub>max</sub>	(°F)	90 (194)			
	Protection class	IP54					
<b>S</b>	Standard lubrication	Grease (lifetime lubrication)					
<b>F</b>	Food grade lubrication	Grease (lifetime lubrication)					
<b>L</b>	Low temperature lubrication <sup>(3)</sup>	Grease (lifetime lubrication)					
	Installation position	Any					
<b>S</b>	Standard backlash	j <sub>t</sub>	arcmin	< 10	< 7	< 7	1
				< 12	< 9	< 9	2
				< 15	< 11	< 11	3
	Torsional stiffness <sup>(2)</sup>	c <sub>g</sub>	Nm /arcmin (lb <sub>f</sub> .in/ arcmin)	2.8 - 4.0 (25 - 35)	8.5 - 12.6 (75 - 112)	14.0 - 18.5 (124 - 164)	1
				3.3 - 4.1 (29 - 36)	9.4 - 13.3 (83 - 118)	15.6 - 19.0 (138 - 168)	2
				3.3 - 4.1 (29 - 36)	9.4 - 13.4 (83 - 119)	15.6 - 19.0 (138 - 168)	3
	Gearbox weight <sup>(2)</sup>	m <sub>G</sub>	kg (lb <sub>m</sub> )	1.1 (2.4)	2.7 - 2.9 (5.8 - 6.5)	6.4 - 6.5 (14.1 - 14.3)	1
				1.3 (2.8)	3.4 - 3.5 (7.5 - 7.6)	8.1 - 8.3 (17.9 - 18.3)	2
				1.5 (3.3)	3.9 - 4.0 (8.6 - 8.8)	9.9 - 10.1 (21.9 - 22.4)	3
<b>S</b>	Standard surface	Housing: Steel – heat-treated and post-oxidized (black)					
	Running noise <sup>(4)</sup>	Q <sub>g</sub>	dB(A)	58	60	65	
	Max. bending moment based on the gearbox input flange <sup>(5)</sup>	M <sub>b</sub>	Nm (lb <sub>f</sub> .in)	12 (106)	16 (142)	40 (354)	

Output shaft loads				PLQE060	PLQE080	PLQE120	p <sup>(1)</sup>
Radial force for 20,000 h <sup>(6)(7)</sup>	F <sub>r,20,000h</sub>	N (lb <sub>f</sub> )		900 (202)	2050 (461)	2950 (663)	
Axial force for 20,000 h <sup>(6)(7)</sup>	F <sub>a,20,000h</sub>			1000 (225)	2500 (562)	2500 (562)	
Radial force for 30,000 h <sup>(6)(7)</sup>	F <sub>r,30,000h</sub>			700 (157)	1700 (382)	2400 (540)	
Axial force for 30,000 h <sup>(6)(7)</sup>	F <sub>a,30,000h</sub>			800 (180)	2000 (450)	2100 (472)	
Maximum radial force <sup>(7)(8)</sup>	F <sub>r,Stat</sub>			1500 (337)	2500 (562)	4000 (899)	
Maximum axial force <sup>(7)(8)</sup>	F <sub>a,Stat</sub>			1950 (438)	3800 (854)	3800 (854)	
Tilting moment for 20,000 h <sup>(6)(8)</sup>	M <sub>K,20,000h</sub>	Nm (lb <sub>f</sub> .in)		37 (327)	101 (894)	232 (2053)	
Tilting moment for 30,000 h <sup>(6)(8)</sup>	M <sub>K,30,000h</sub>			29 (257)	84 (743)	188 (1664)	

Moment of inertia				PLQE060	PLQE080	PLQE120	p <sup>(1)</sup>
Mass moment of inertia <sup>(2)</sup>	J	kgcm <sup>2</sup> (lb <sub>f</sub> .in.s <sup>2</sup> 10 <sup>-4</sup> )		0.066 - 0.142 (0.584 - 1.257)	0.371 - 0.783 (3.284 - 6.930)	1.381 - 2.393 (12.223 - 21.180)	1
				0.066 - 0.123 (0.584 - 1.089)	0.366 - 0.625 (3.239 - 5.532)	1.414 - 2.292 (12.515 - 20.286)	2
				0.066 - 0.076 (0.584 - 0.673)	0.365 - 0.590 (3.231 - 5.222)	1.413 - 2.196 (12.506 - 19.436)	3

(1) Number of stages  
 (2) The ratio-dependent values can be retrieved in Tec Data Finder – www.neugart.com  
 (3) T<sub>min</sub> = -40°C. Optimal operating temperature max. 50°C  
 (4) Sound pressure level from 1 m, measured on input running at n<sub>i</sub>=3000 rpm no load; i=5  
 (5) Max. motor weight\* in kg = 0.2 x M<sub>m</sub> / motor length in m  
 \* with symmetrically distributed motor weight  
 \* with horizontal and stationary mounting  
 (6) These values are based on an output shaft speed of n<sub>2</sub>=100 rpm  
 (7) Based on center of output shaft  
 (8) Other (sometimes higher) values following changes to T<sub>2N</sub>, F<sub>r</sub>, F<sub>a</sub>, cycle, and service life of bearing. Application specific configuration with NCP – www.neugart.com

Output torques			PLQE060	PLQE080	PLQE120	i <sup>(1)</sup>	p <sup>(2)</sup>
Nominal output torque <sup>(3)(4)</sup>	T <sub>2N</sub>	Nm (lb <sub>r</sub> .in)	28 (248)	85 (752)	115 (1018)	3	1
			38 (336)	115 (1018)	155 (1372)	4	
			40 (354)	110 (974)	195 (1726)	5	
			25 (221)	65 (575)	135 (1195)	7	
			18 (159)	50 (443)	120 (1062)	8	
			15 (133)	38 (336)	95 (841)	10	
			44 (389)	130 (1151)	210 (1859)	9	2
			44 (389)	120 (1062)	260 (2301)	12	
			44 (389)	110 (974)	230 (2036)	15	
			44 (389)	120 (1062)	260 (2301)	16	
			44 (389)	120 (1062)	260 (2301)	20	
			40 (354)	110 (974)	230 (2036)	25	
			44 (389)	120 (1062)	260 (2301)	32	3
			40 (354)	110 (974)	230 (2036)	40	
			18 (159)	50 (443)	120 (1062)	64	
			44 (389)	110 (974)	260 (2301)	60	
			44 (389)	120 (1062)	260 (2301)	80	
			44 (389)	120 (1062)	260 (2301)	100	
			44 (389)	110 (974)	230 (2036)	120	3
			44 (389)	120 (1062)	260 (2301)	160	
			40 (354)	110 (974)	230 (2036)	200	
			44 (389)	120 (1062)	260 (2301)	256	
			40 (354)	110 (974)	230 (2036)	320	
			18 (159)	50 (443)	120 (1062)	512	
Max. output torque <sup>(4)(5)</sup>	T <sub>2max</sub>	Nm (lb <sub>r</sub> .in)	45 (398)	136 (1204)	184 (1629)	3	1
			61 (540)	184 (1629)	248 (2195)	4	
			64 (566)	176 (1558)	312 (2761)	5	
			40 (354)	104 (920)	216 (1912)	7	
			29 (257)	80 (708)	192 (1699)	8	
			24 (212)	61 (540)	152 (1345)	10	
			70 (620)	208 (1841)	336 (2974)	9	2
			70 (620)	192 (1699)	416 (3682)	12	
			70 (620)	176 (1558)	368 (3257)	15	
			70 (620)	192 (1699)	416 (3682)	16	
			70 (620)	192 (1699)	416 (3682)	20	
			64 (566)	176 (1558)	368 (3257)	25	
			70 (620)	192 (1699)	416 (3682)	32	3
			64 (566)	176 (1558)	368 (3257)	40	
			29 (257)	80 (708)	192 (1699)	64	
			70 (620)	176 (1558)	416 (3682)	60	
			70 (620)	192 (1699)	416 (3682)	80	
			70 (620)	192 (1699)	416 (3682)	100	
			70 (620)	176 (1558)	368 (3257)	120	3
			70 (620)	192 (1699)	416 (3682)	160	
			64 (566)	176 (1558)	368 (3257)	200	
			70 (620)	192 (1699)	416 (3682)	256	
			64 (566)	176 (1558)	368 (3257)	320	
			29 (257)	80 (708)	192 (1699)	512	

PLQE

(1) Ratios (i=n<sub>1</sub>/n<sub>2</sub>)  
 (2) Number of stages  
 (3) Application specific configuration with NCP – www.neugart.com  
 (4) Values for feather key (code "A"): for repeated load  
 (5) 30,000 rotations of the output shaft permitted; see page 164

PLQE

Output torques			PLQE060	PLQE080	PLQE120	i <sup>(1)</sup>	p <sup>(2)</sup>
Emergency stop torque <sup>(3)</sup>	T <sub>2Stop</sub>	Nm (lb <sub>r</sub> .in)	66 (584)	180 (1593)	390 (3452)	3	1
			88 (779)	240 (2124)	520 (4602)	4	
			80 (708)	220 (1947)	500 (4425)	5	
			80 (708)	178 (1575)	340 (3009)	7	
			80 (708)	190 (1682)	380 (3363)	8	
			80 (708)	200 (1770)	480 (4248)	10	
			88 (779)	260 (2301)	500 (4425)	9	2
			88 (779)	240 (2124)	520 (4602)	12	
			88 (779)	220 (1947)	500 (4425)	15	
			88 (779)	240 (2124)	520 (4602)	16	
			88 (779)	240 (2124)	520 (4602)	20	
			80 (708)	220 (1947)	500 (4425)	25	
			88 (779)	240 (2124)	520 (4602)	32	3
			80 (708)	220 (1947)	500 (4425)	40	
			80 (708)	190 (1682)	380 (3363)	64	
			88 (779)	220 (1947)	520 (4602)	60	
			88 (779)	240 (2124)	520 (4602)	80	
			88 (779)	240 (2124)	520 (4602)	100	
			88 (779)	220 (1947)	500 (4425)	120	3
			88 (779)	240 (2124)	520 (4602)	160	
			80 (708)	220 (1947)	500 (4425)	200	
			88 (779)	240 (2124)	520 (4602)	256	
			80 (708)	220 (1947)	500 (4425)	320	
			80 (708)	190 (1682)	380 (3363)	512	

Input speeds			PLQE060	PLQE080	PLQE120	i <sup>(1)</sup>	p <sup>(2)</sup>
Average thermal input speed at T <sub>2N</sub> and S1 <sup>(4)(5)</sup>	n <sub>1N</sub>	rpm	4500 <sup>(6)</sup>	3400 <sup>(6)</sup>	3400 <sup>(6)</sup>	3	1
			4500 <sup>(6)</sup>	3450 <sup>(6)</sup>	3500 <sup>(6)</sup>	4	
			4500	4000 <sup>(6)</sup>	3500 <sup>(6)</sup>	5	
			4500	4000	3500	7	
			4500	4000	3500	8	
			4500	4000	3500	10	
			4500	4000 <sup>(6)</sup>	3500 <sup>(6)</sup>	9	2
			4500	4000 <sup>(6)</sup>	3500 <sup>(6)</sup>	12	
			4500	4000	3500 <sup>(6)</sup>	15	
			4500	4000	3500 <sup>(6)</sup>	16	
			4500	4000	3500	20	
			4500	4000	3500	25	
			4500	4000	3500	32	3
			4500	4000	3500	40	
			4500	4000	3500	64	
			4500	4000	3500	60	
			4500	4000	3500	80	
			4500	4000	3500	100	
			4500	4000	3500	120	3
			4500	4000	3500	160	
			4500	4000	3500	200	
			4500	4000	3500	256	
			4500	4000	3500	320	
			4500	4000	3500	512	
Max. mechanical input speed <sup>(4)</sup>	n <sub>1Limit</sub>	rpm	13,000	7000	6500		

(1) Ratios (i=n<sub>1</sub>/n<sub>2</sub>)  
 (2) Number of stages  
 (3) Permitted 1000 times  
 (4) Application-specific speed configurations with NCP – www.neugart.com  
 (5) See page 164 for the definition  
 (6) Average thermal input speed at 50% T<sub>2N</sub> and S1

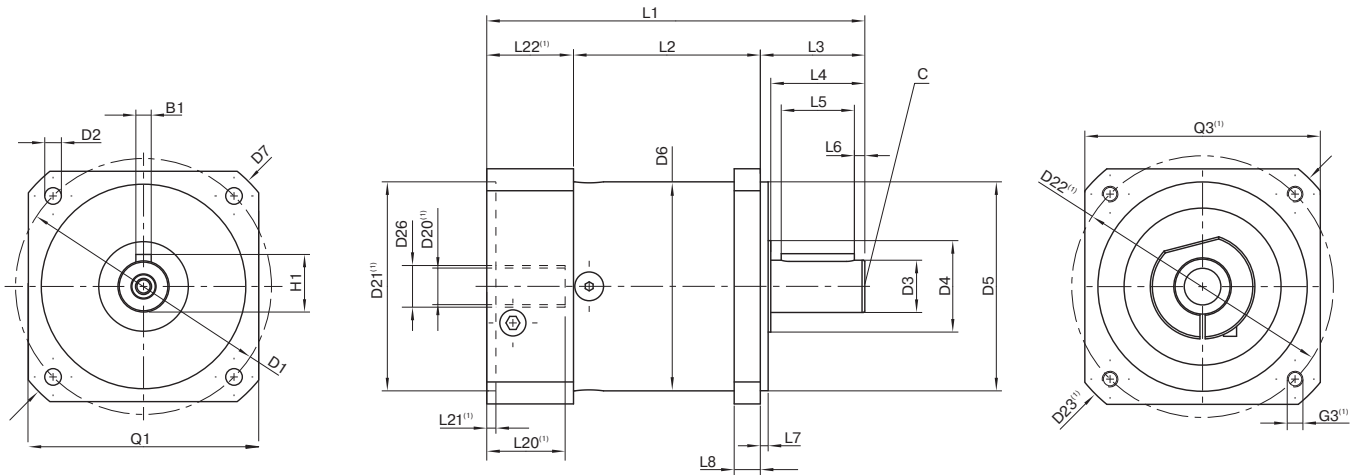

Drawing corresponds to a PLQE080 / 1-stage / output shaft with feather key / 19 mm clamping system / motor adaptation – one part / B5 flange type motor

<sup>(1)</sup>The dimensions vary with the motor/gearbox flange. The input flange dimensions can be retrieved for each specific motor in Tec Data Finder at [www.neugart.com](http://www.neugart.com)

Geometry <sup>(2)</sup>			PLQE060	PLQE080	PLQE120	p <sup>(3)</sup>	Code
Pitch circle diameter output	D1		75 (2.953)	100 (3.937)	130 (5.118)		
Mounting bore output	D2	4x	5.5 (0.217)	6.5 (0.256)	8.5 (0.335)		
Shaft diameter output	D3	h7	16 (0.630)	20 (0.787)	25 (0.984)		
Shaft collar output	D4		20 (0.787)	35 (1.378)	35 (1.378)		
Centering diameter output	D5	h7	60 (2.362)	80 (3.150)	110 (4.331)		
Housing diameter	D6		60 (2.362)	80 (3.150)	115 (4.528)		
Diagonal dimension output	D7		92 (3.622)	116 (4.567)	145 (5.709)		
Flange cross section output	Q1	■	70 (2.756)	90 (3.543)	115 (4.528)		
Min. total length	L1		111 (4.370)	145 (5.709)	201.5 (7.933)	1	
			123.5 (4.862)	162.5 (6.398)	229.5 (9.035)	2	
			136 (5.354)	180 (7.087)	257 (10.118)	3	
Housing length	L2		55 (2.165)	71 (2.795)	99 (3.898)	1	
			67.5 (2.657)	89 (3.504)	127 (5.000)	2	
			80.5 (3.169)	106.5 (4.193)	154.5 (6.083)	3	
Shaft length output	L3		32 (1.260)	40 (1.575)	55 (2.165)		
Centering depth output	L7		3 (0.118)	3 (0.118)	4 (0.157)		
Flange thickness output	L8		10 (0.394)	10 (0.394)	15 (0.591)		
Motor shaft diameter j6/k6	D20		More information on page 161/162				
Clamping system diameter input	D26		More information on page 161/162				
Output shaft with feather key (DIN 6885-1)			A 5x5x20	A 6x6x28	A 8x7x40		A
Feather key width (DIN 6885-1)	B1		5 (0.197)	6 (0.236)	8 (0.315)		
Shaft height including feather key (DIN 6885-1)	H1		18 (0.709)	22.5 (0.886)	28 (1.102)		
Shaft length from shoulder	L4		28 (1.102)	36 (1.417)	50 (1.969)		
Feather key length	L5		20 (0.787)	28 (1.102)	40 (1.575)		
Distance from shaft end	L6		4 (0.157)	4 (0.157)	5 (0.197)		
Center hole (DIN 332. type DR)	C		M5x12.5	M6x16	M10x22		
Smooth output shaft							B
Shaft length from shoulder	L4		28 (1.102)	36 (1.417)	50 (1.969)		

<sup>(2)</sup> Dimensions in mm

<sup>(3)</sup> Number of stages