

PLHE

This is progress:
In this planetary gearbox, precision and cost effectiveness meet

The **PLHE** is our ideal combination of economy and precision gearboxes. The preloaded tapered roller bearings of this planetary gearbox guarantee high rigidity even under maximum load. The high-performance seal provides increased protection against dust and water spray.

Nominal output torque **15 - 260 Nm**

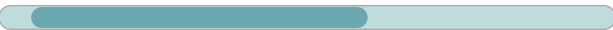

Radial force **3200 - 6000 N**

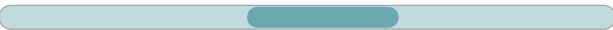

Axial force **4400 - 8000 N**



Torsional backlash **7 - 12 arcmin**



Protection class **IP65**



Frame sizes

60	80	120
-----------	-----------	------------

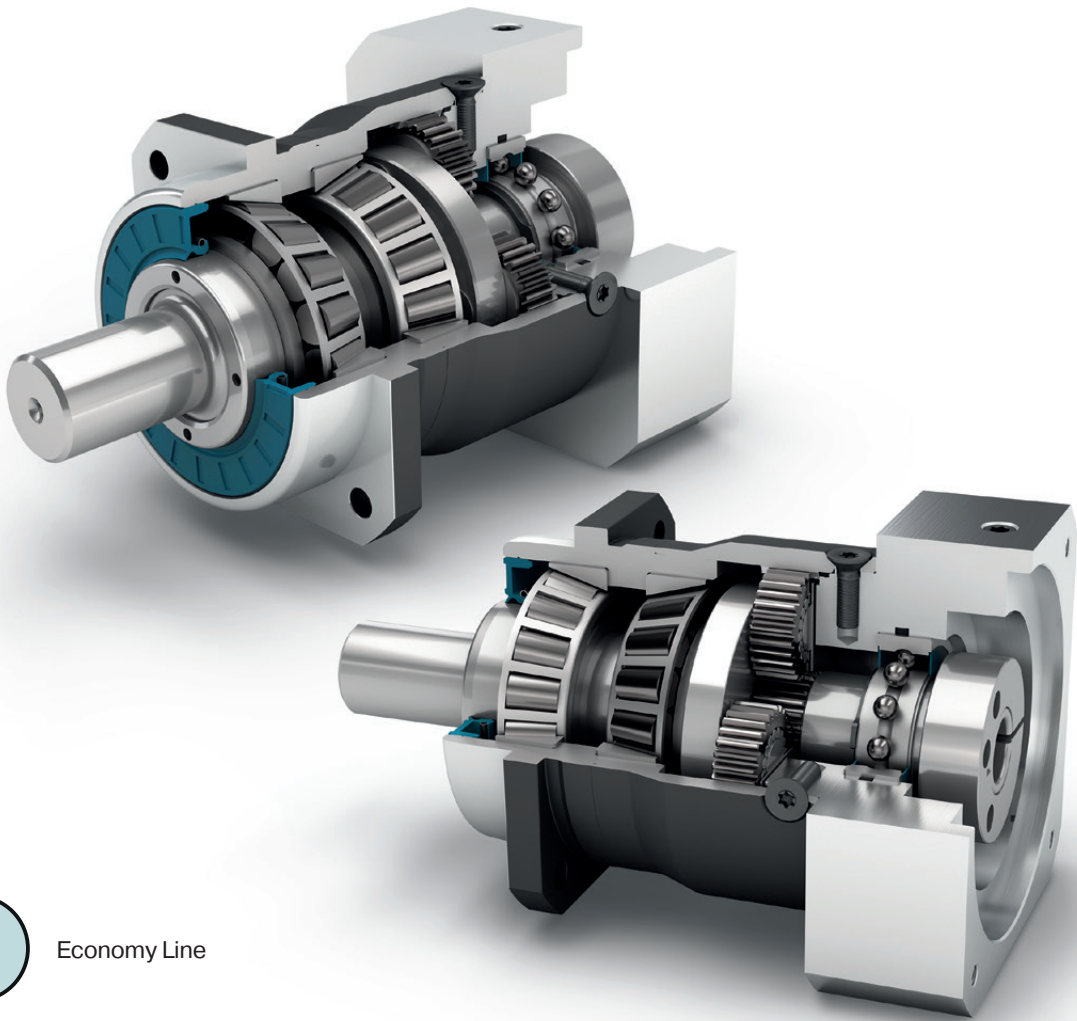

Economy Line

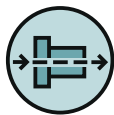

Coaxial gearbox



Spur gear



Preloaded tapered roller bearings



Extra long centering collar



Option: Splined output shaft (DIN 5480)



Equidirectional rotation

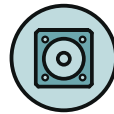

Square type output flange



Rotary shaft seal



Planet carrier in disc design



Option: Planetary gearbox with mounted pinion on page 132

Detailed explanations of the technical features starting on page 171.

Code	Gearbox characteristics			PLHE060	PLHE080	PLHE120	p ⁽¹⁾	
	Service life (L _{10h})	t _L	h	30,000				
	Efficiency at full load ⁽²⁾	η	%	97			1	
				96			2	
	Min. operating temperature	T _{min}	°C	-25 (-13)				
	Max. operating temperature	T _{max}	(°F)	90 (194)				
	Protection class				IP65			
S	Standard lubrication				Grease (lifetime lubrication)			
F	Food grade lubrication				Grease (lifetime lubrication)			
L	Low temperature lubrication ⁽³⁾				Grease (lifetime lubrication)			
	Installation position				Any			
S	Standard backlash	j _t	arcmin	< 10	< 7	< 7	1	
				< 12	< 9	< 9	2	
	Torsional stiffness ⁽²⁾	c _g	Nm /arcmin (lb _f .in / arcmin)	2.6 - 4.4 (23 - 39)	7.3 - 11.6 (65 - 103)	18.5 - 26.0 (164 - 230)	1	
				2.5 - 4.6 (22 - 41)	7.3 - 12.3 (65 - 109)	16.7 - 27.5 (148 - 243)	2	
	Gearbox weight ⁽²⁾	m _G	kg (lb _m)	1.5 - 1.6 (3.3 - 3.5)	3.0 (6.6)	6.8 - 7.0 (15.1 - 15.4)	1	
				1.7 - 1.8 (3.8 - 3.9)	3.5 - 4.0 (7.7 - 8.8)	8.5 - 8.8 (18.8 - 19.5)	2	
S	Standard surface				Housing: Steel – heat-treated and post-oxidized (black)			
	Running noise ⁽⁴⁾	Q _g	dB(A)	58	60	65		
	Max. bending moment based on the gearbox input flange ⁽⁵⁾	M _b	Nm (lb _f .in)	8 (71)	16 (142)	40 (354)		

Output shaft loads			PLHE060	PLHE080	PLHE120	p ⁽¹⁾
Radial force for 20,000 h ⁽⁶⁾⁽⁷⁾	F _{r 20.000 h}	N (lb _f)	3200 (719)	5500 (1236)	6000 (1349)	
Axial force for 20,000 h ⁽⁶⁾⁽⁷⁾	F _{a 20.000 h}		4400 (989)	6400 (1439)	8000 (1798)	
Radial force for 30,000 h ⁽⁶⁾⁽⁷⁾	F _{r 30.000 h}		3200 (719)	4800 (1079)	5400 (1214)	
Axial force for 30,000 h ⁽⁶⁾⁽⁷⁾	F _{a 30.000 h}		3900 (877)	5700 (1281)	7000 (1574)	
Maximum radial force ⁽⁷⁾⁽⁸⁾	F _{r Stat}		3200 (719)	5500 (1236)	6000 (1349)	
Maximum axial force ⁽⁷⁾⁽⁸⁾	F _{a Stat}		4400 (989)	6400 (1439)	8000 (1798)	
Tilting moment for 20,000 h ⁽⁶⁾⁽⁸⁾	M _{K 20.000 h}	Nm (lb _f .in)	191 (1690)	383 (3390)	488 (4319)	
Tilting moment for 30,000 h ⁽⁶⁾⁽⁸⁾	M _{K 30.000 h}		191 (1690)	335 (2965)	439 (3885)	

Moment of inertia			PLHE060	PLHE080	PLHE120	p ⁽¹⁾
Mass moment of inertia ⁽²⁾	J	kgcm ² (lb _f .in.s ² 10 ⁻⁴)	0.069 - 0.178 (0.611 - 1.575)	0.370 - 0.775 (3.275 - 6.859)	1.390 - 2.486 (12.303 - 22.003)	1
			0.064 - 0.135 (0.566 - 1.195)	0.357 - 0.641 (3.160 - 5.673)	1.378 - 2.326 (12.196 - 20.587)	2

(1) Number of stages
 (2) The ratio-dependent values can be retrieved in Tec Data Finder – www.neugart.com
 (3) T_{min} = -40°C. Optimal operating temperature max. 50°C
 (4) Sound pressure level from 1 m, measured on input running at n_i=3000 rpm no load; i=5
 (5) Max. motor weight* in kg = 0.2 x M_b / motor length in m
 * with symmetrically distributed motor weight
 * with horizontal and stationary mounting
 (6) These values are based on an output shaft speed of n₂=100 rpm
 (7) Based on center of output shaft
 (8) Other (sometimes higher) values following changes to T_{2n}, F_r, F_a, cycle, and service life of bearing. Application specific configuration with NCP – www.neugart.com

Output torques			PLHE060	PLHE080	PLHE120	i ⁽¹⁾	p ⁽²⁾
Nominal output torque ⁽³⁾⁽⁴⁾	T _{2N}	Nm (lb _r .in)	28 (248)	85 (752)	115 (1018)	3	1
			38 (336)	115 (1018)	155 (1372)	4	
			40 (354)	110 (974)	195 (1726)	5	
			25 (221)	65 (575)	135 (1195)	7	
			18 (159)	50 (443)	120 (1062)	8	
			15 (133)	38 (336)	95 (841)	10	
			44 (389)	130 (1151)	210 (1859)	9	2
			44 (389)	120 (1062)	260 (2301)	12	
			44 (389)	110 (974)	230 (2036)	15	
			44 (389)	120 (1062)	260 (2301)	16	
			44 (389)	120 (1062)	260 (2301)	20	
			40 (354)	110 (974)	230 (2036)	25	
			44 (389)	120 (1062)	260 (2301)	32	
			40 (354)	110 (974)	230 (2036)	40	
			18 (159)	50 (443)	120 (1062)	64	
			15 (133)	38 (336)	95 (841)	100	
Max. output torque ⁽⁴⁾⁽⁵⁾	T _{2max}	Nm (lb _r .in)	45 (398)	136 (1204)	184 (1629)	3	1
			61 (540)	184 (1629)	248 (2195)	4	
			64 (566)	176 (1558)	312 (2761)	5	
			40 (354)	104 (920)	216 (1912)	7	
			29 (257)	80 (708)	192 (1699)	8	
			24 (212)	61 (540)	152 (1345)	10	
			70 (620)	208 (1841)	336 (2974)	9	2
			70 (620)	192 (1699)	416 (3682)	12	
			70 (620)	176 (1558)	368 (3257)	15	
			70 (620)	192 (1699)	416 (3682)	16	
			70 (620)	192 (1699)	416 (3682)	20	
			64 (566)	176 (1558)	368 (3257)	25	
			70 (620)	192 (1699)	416 (3682)	32	
			64 (566)	176 (1558)	368 (3257)	40	
			29 (257)	80 (708)	192 (1699)	64	
			24 (212)	61 (540)	152 (1345)	100	

PLHE

(1) Ratios (i=n₁/n₂)
 (2) Number of stages
 (3) Application specific configuration with NCP – www.neugart.com
 (4) Values for feather key (code "A"): for repeated load
 (5) 30,000 rotations of the output shaft permitted; see page 164

Output torques			PLHE060	PLHE080	PLHE120	$i^{(1)}$	$p^{(2)}$						
Emergency stop torque ⁽³⁾	T_{2Stop}	Nm (lb _f .in)	66 (584)	180 (1593)	390 (3452)	3	1						
			88 (779)	240 (2124)	520 (4602)	4							
			80 (708)	220 (1947)	500 (4425)	5							
			80 (708)	178 (1575)	340 (3009)	7							
			80 (708)	190 (1682)	380 (3363)	8							
			80 (708)	200 (1770)	480 (4248)	10							
			88 (779)	260 (2301)	500 (4425)	9							
			88 (779)	240 (2124)	520 (4602)	12							
			88 (779)	220 (1947)	500 (4425)	15							
		88 (779)	240 (2124)	520 (4602)	16	20	25	32	2				
										88 (779)	240 (2124)	520 (4602)	20
										80 (708)	220 (1947)	500 (4425)	25
										88 (779)	240 (2124)	520 (4602)	32
										80 (708)	220 (1947)	500 (4425)	40
										80 (708)	190 (1682)	380 (3363)	64
										80 (708)	200 (1770)	480 (4248)	100

Input speeds			PLHE060	PLHE080	PLHE120	$i^{(1)}$	$p^{(2)}$						
Average thermal input speed at T_{2N} and S1 ⁽⁴⁾⁽⁵⁾	n_{1N}	rpm	2950 ⁽⁶⁾	2450 ⁽⁶⁾	2150 ⁽⁶⁾	3	1						
			3500 ⁽⁶⁾	2700 ⁽⁶⁾	2400 ⁽⁶⁾	4							
			4200 ⁽⁶⁾	3250 ⁽⁶⁾	2600 ⁽⁶⁾	5							
			4500	4000	3500 ⁽⁶⁾	7							
			4500	4000	3500 ⁽⁶⁾	8							
			4500	4000	3500	10							
			4500 ⁽⁶⁾	4000 ⁽⁶⁾	3050 ⁽⁶⁾	9							
			4500	4000 ⁽⁶⁾	3200 ⁽⁶⁾	12							
			4500	4000	3500 ⁽⁶⁾	15							
		4500	4000	3500 ⁽⁶⁾	20	25	32	40	2				
										4500	4000	3500 ⁽⁶⁾	20
										4500	4000	3500 ⁽⁶⁾	25
										4500	4000	3500	32
										4500	4000	3500	40
										4500	4000	3500	64
										4500	4000	3500	100

Max. mechanical input speed ⁽⁴⁾	n_{1Limit}	rpm	13,000	7000	6500		
--	--------------	-----	--------	------	------	--	--

(1) Ratios ($i=n_1/n_2$)
 (2) Number of stages
 (3) Permitted 1000 times
 (4) Application-specific speed configurations with NCP – www.neugart.com
 (5) See page 164 for the definition
 (6) Average thermal input speed at 50% T_{2N} and S1

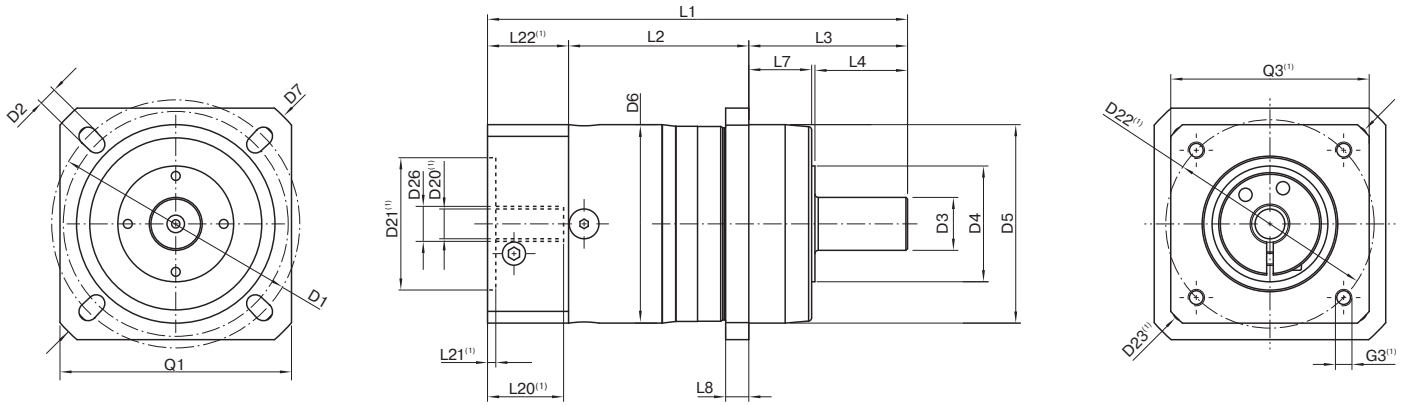

Drawing corresponds to a PLHE060 / 1-stage / smooth output shaft / 11 mm clamping system / motor adaptation – one part / B5 flange type motor

⁽¹⁾ The dimensions vary with the motor/gearbox flange. The input flange dimensions can be retrieved for each specific motor in Tec Data Finder at www.neugart.com

Geometry ⁽²⁾			PLHE060	PLHE080	PLHE120	p ⁽³⁾	Code
Pitch circle diameter output	D1		68 - 75 (2.677 - 2.953)	85 (3.346)	120 (4.724)		
Mounting bore output	D2	4x	5.5 (0.217)	6.5 (0.256)	9.0 (0.354)		
Shaft diameter output	D3	k6	16 (0.630)	22 (0.866)	32 (1.260)		
Shaft collar output	D4		35 (1.378)	40 (1.575)	45 (1.772)		
Centering diameter output	D5	g7	60 (2.362)	70 (2.756)	90 (3.543)		
Housing diameter	D6		60 (2.362)	80 (3.150)	115 (4.528)		
Diagonal dimension output	D7		92 (3.622)	100 (3.937)	140 (5.512)		
Flange cross section output	Q1	■	70 (2.756)	80 (3.150)	110 (4.331)		
Min. total length	L1		127 (5.000)	159 (6.260)	199.5 (7.854)	1	
			139.5 (5.492)	177 (6.969)	227 (8.937)	2	
Housing length	L2		55 (2.165)	69.5 (2.736)	64 (2.520)	1	
			67.5 (2.657)	87 (3.445)	91.5 (3.602)	2	
Shaft length output	L3		48 (1.890)	56 (2.205)	88 (3.465)		
Centering depth output	L7		19 (0.748)	17.5 (0.689)	28 (1.102)		
Flange thickness output	L8		7 (0.276)	8 (0.315)	10 (0.394)		
Motor shaft diameter j6/k6	D20		More information on page 161/162				
Clamping system diameter input	D26		More information on page 161/162				
Output shaft with feather key (DIN 6885-1)			A 5x5x25	A 6x6x28	A 10x8x50		A
Feather key width (DIN 6885-1)	B1		5 (0.197)	6 (0.236)	10 (0.394)		
Shaft height including feather key (DIN 6885-1)	H1		18 (0.709)	24.5 (0.965)	35 (1.378)		
Shaft length from shoulder	L4		28 (1.102)	36 (1.417)	58 (2.283)		
Feather key length	L5		25 (0.984)	28 (1.102)	50 (1.969)		
Distance from shaft end	L6		2 (0.079)	4 (0.157)	4 (0.157)		
Center hole (DIN 332. type DR)	C		M5x12.5	M8x19	M12x28		
Smooth output shaft							B
Shaft length from shoulder	L4		28 (1.102)	36 (1.417)	58 (2.283)		
Splined output shaft (DIN 5480)			W16x0,8x18x6m	W22x1,25x16x6m	W32x1,25x24x6m		C
Width of gearing	L _v		15 (0.591)	15 (0.591)	15 (0.591)		
Shaft length output	L3		48 (1.890)	56 (2.205)	88 (3.465)		
Shaft length from shoulder	L4		26 (1.024)	26 (1.024)	26 (1.024)		
Center hole (DIN 332. type DR)	C		M5x12,5	M8x19	M12x28		

⁽²⁾ Dimensions in mm

⁽³⁾ Number of stages