



WGN

The spiral right angle gearbox with hollow shaft – low noise levels and force-fit installation

Our **WGN** is a hollow-shaft right angle gearbox that operates with particularly low noise levels. At the same time, the spiral teeth increase the quality of your workpiece surfaces. It can be connected directly to the application via a shrink disc, a simple and reliable solution that offers you new design possibilities.

Nominal output torque **22 - 320 Nm**

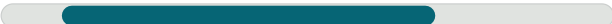

Torsional backlash **5 arcmin**

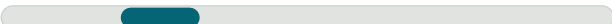

Tilting moment **252 - 1505 Nm**

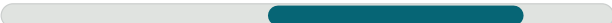

Protection class **IP65**



Frame sizes

70

90

115

142

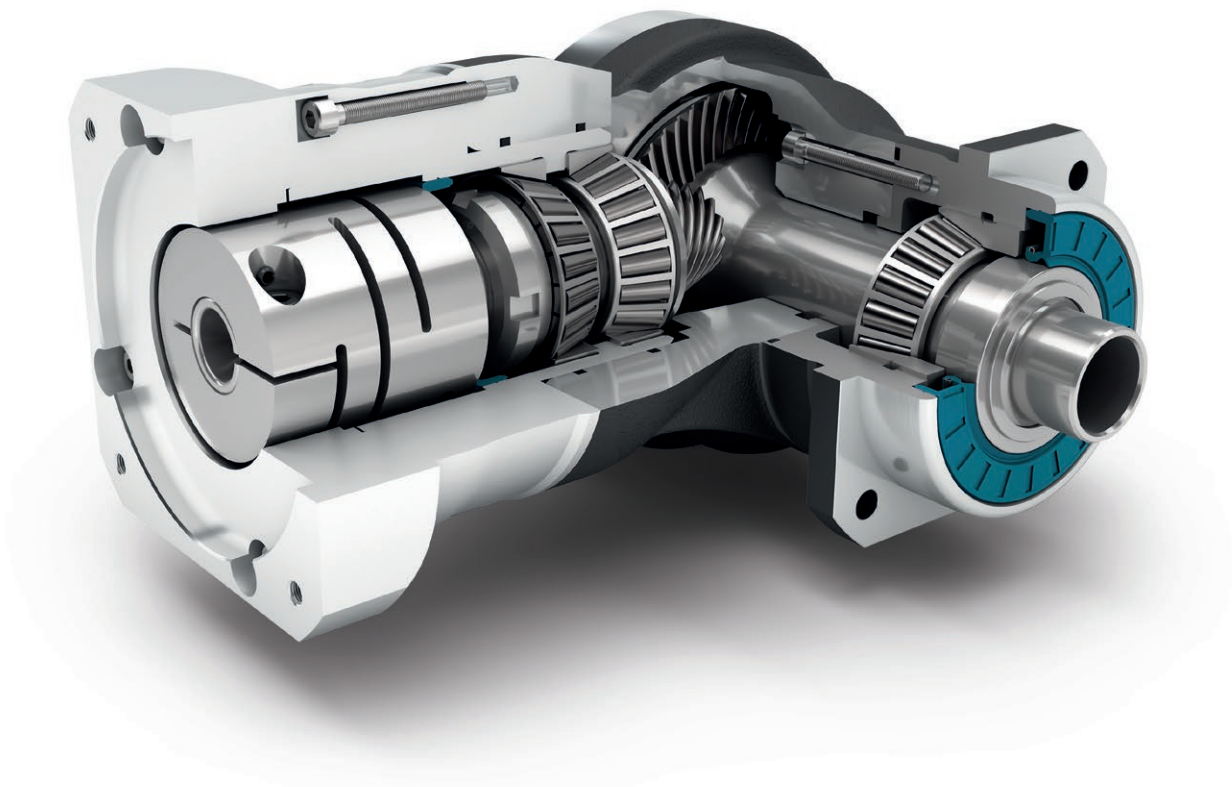

Precision Line



Right angle gearbox



Hypoid gear right angle stage



Preloaded tapered roller bearings



Extra long centering collar



Counterdirectional rotation



Square type output flange



Rotary shaft seal



Hollow shaft for clamping system with shrink disc

Code	Gearbox characteristics			WGN070	WGN090	WGN115	WGN142	p ⁽¹⁾
	Service life (L _{10h})	t _L	h	20,000				
	Service life at T _{2N} x 0.88			30,000				
	Efficiency at full load ⁽²⁾	η	%	95				
	Min. operating temperature	T _{min}	°C	-25 (-13)				
	Max. operating temperature	T _{max}	(°F)	90 (194)				
	Protection class			IP65				
S	Standard lubrication			Oil (lifetime lubrication)				
F	Food grade lubrication			Oil (lifetime lubrication)				
	Installation position			Any				
S	Standard backlash	j _t	arcmin	< 5				
	Torsional stiffness ⁽²⁾	c _G	Nm/arcmin (lb _r .in/ arcmin)	1.6 - 2.2 (14 - 19)	4.2 - 5.7 (37 - 50)	9.2 - 12.4 (81 - 110)	23.5 - 31.5 (208 - 279)	
	Gearbox weight	m _G	kg (lb _m)	3 (6.6)	5 (11.0)	9.2 (20.3)	25 (55.1)	
S	Standard surface			Right angle housing: Aluminum – anodized (black)				
	Running noise ⁽³⁾	Q _G	dB(A)	66	67	68	70	
	Max. bending moment based on the gearbox input flange ⁽⁴⁾	M _b	Nm (lb _r .in)	12 (106)	25.5 (226)	53 (469)	120 (1062)	

Output shaft loads			WGN070	WGN090	WGN115	WGN142	p ⁽¹⁾
Radial force for 20,000 h ⁽⁵⁾⁽⁶⁾	F _{r 20.000h}	N (lb _r)	2700 (607)	4000 (899)	6500 (1461)	10000 (2248)	
Axial force for 20,000 h ⁽⁵⁾⁽⁶⁾	F _{a 20.000h}		4300 (967)	5900 (1326)	7000 (1574)	14500 (3260)	
Radial force for 30,000 h ⁽⁵⁾⁽⁶⁾	F _{r 30.000h}		2700 (607)	4000 (899)	6500 (1461)	10000 (2248)	
Axial force for 30,000 h ⁽⁵⁾⁽⁶⁾	F _{a 30.000h}		3700 (832)	5200 (1169)	6100 (1371)	12000 (2698)	
Maximum radial force ⁽⁶⁾⁽⁷⁾	F _{r Stat}		2700 (607)	4000 (899)	6500 (1461)	10000 (2248)	
Maximum axial force ⁽⁶⁾⁽⁷⁾	F _{a Stat}		4300 (967)	5900 (1326)	7000 (1574)	14500 (3260)	
Tilting moment for 20,000 h ⁽⁵⁾⁽⁷⁾	M _{K 20.000h}	Nm (lb _r .in)	252 (2230)	442 (3912)	970 (8585)	1505 (13320)	
Tilting moment for 30,000 h ⁽⁵⁾⁽⁷⁾	M _{K 30.000h}		252 (2230)	442 (3912)	970 (8585)	1505 (13320)	

Moment of inertia			WGN070	WGN090	WGN115	WGN142	p ⁽¹⁾
Mass moment of inertia ⁽²⁾	J	kgcm ² (lb _r .in.s ² 10 ⁻⁴)	0.502 - 0.834 (4.443 - 7.382)	1.018 - 1.417 (9.010 - 12.542)	4.805 - 6.111 (42.528 - 54.087)	12.934 - 18.905 (114.476 - 167.323)	

(1) Number of stages
(2) The ratio-dependent values can be retrieved in Tec Data Finder – www.neugart.com
(3) Sound pressure level from 1 m, measured on input running at n₁=3000 rpm no load; i=5
(4) Max. motor weight* in kg = 0.2 x M_b / motor length in m
* with symmetrically distributed motor weight
* with horizontal and stationary mounting
(5) These values are based on an output shaft speed of n₂=100 rpm
(6) Based on center of output shaft
(7) Other (sometimes higher) values following changes to T_{2N}, F_r, F_a, cycle, and service life of bearing. Application specific configuration with NCP – www.neugart.com

Output torques			WGN070	WGN090	WGN115	WGN142	i ⁽¹⁾	p ⁽²⁾
Nominal output torque ⁽³⁾	T _{2N}	Nm (lb _f .in)	45 (398)	70 (620)	140 (1239)	320 (2832)	4	1
			42 (372)	70 (620)	140 (1239)	280 (2478)	5	
			28 (248)	51 (451)	91 (805)	189 (1673)	7	
			27 (239)	50 (443)	90 (797)	180 (1593)	8	
			22 (195)	40 (354)	75 (664)	160 (1416)	10	
Max. output torque ⁽⁴⁾	T _{2max}	Nm (lb _f .in)	72 (637)	112 (991)	224 (1983)	512 (4532)	4	
			67 (593)	112 (991)	224 (1983)	448 (3965)	5	
			45 (398)	82 (726)	145 (1283)	302 (2673)	7	
			43 (381)	80 (708)	144 (1275)	288 (2549)	8	
			35 (310)	64 (566)	120 (1062)	256 (2266)	10	
Emergency stop torque ⁽⁵⁾	T _{2Stop}	Nm (lb _f .in)	100 (885)	200 (1770)	400 (3540)	800 (7081)	4	
			100 (885)	200 (1770)	400 (3540)	800 (7081)	5	
			75 (664)	150 (1328)	300 (2655)	700 (6196)	7	
			75 (664)	150 (1328)	300 (2655)	700 (6196)	8	
			75 (664)	150 (1328)	300 (2655)	700 (6196)	10	

Input speeds			WGN070	WGN090	WGN115	WGN142	i ⁽¹⁾	p ⁽²⁾
Average thermal input speed at T _{2N} and S1 ⁽⁶⁾⁽⁷⁾	n _{1N}	rpm	1750 ⁽⁸⁾	1700 ⁽⁸⁾	1150 ⁽⁸⁾	950 ⁽⁸⁾	4	1
			1900 ⁽⁸⁾	1850 ⁽⁸⁾	1200 ⁽⁸⁾	1000 ⁽⁸⁾	5	
			2250 ⁽⁸⁾	2200 ⁽⁸⁾	1400 ⁽⁸⁾	1200 ⁽⁸⁾	7	
			2300 ⁽⁸⁾	2200 ⁽⁸⁾	1400 ⁽⁸⁾	1200 ⁽⁸⁾	8	
			2400 ⁽⁸⁾	2350 ⁽⁸⁾	1500 ⁽⁸⁾	1300 ⁽⁸⁾	10	
Max. mechanical input speed ⁽⁶⁾	n _{1Limit}	rpm	16000	14000	9500	8000		

(1) Ratios (i=n₁/n₂)
 (2) Number of stages
 (3) Application specific configuration with NCP – www.neugart.com
 (4) 30,000 rotations of the output shaft permitted; see page 142
 (5) Permitted 1000 times
 (6) Application-specific speed configurations with NCP – www.neugart.com
 (7) See page 142 for the definition
 (8) Average thermal input speed at 50% T_{2N} and S1

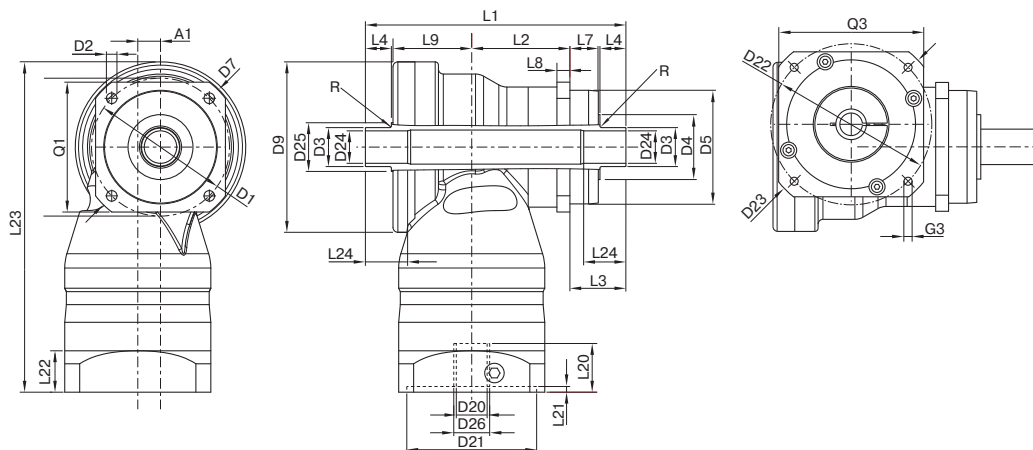

Drawing corresponds to a WGN090 / 1-stage / hollow output shaft on both sides / 19 mm clamping system / motor adaptation – 2-part – round universal flange / B5 flange type motor
 All other variants can be retrieved in the Tec Data Finder at www.neugart.com

Geometry ⁽¹⁾			WGN070	WGN090	WGN115	WGN142	z ⁽²⁾	Code		
Axis offset	A1		10 (0.394)	14 (0.551)	20 (0.787)	26 (1.024)				
Pitch circle diameter output	D1		68 - 75 (2.677 - 2.953)	85 (3.346)	120 (4.724)	165 (6.496)				
Mounting bore output	D2	4x	5.5 (0.217)	6.5 (0.256)	9.0 (0.354)	11.0 (0.433)				
Shaft diameter output	D3	h8	18 (0.709)	24 (0.945)	36 (1.417)	50 (1.969)				
Shaft collar output	D4		30 (1.181)	34 (1.339)	45 (1.772)	70 (2.756)				
Centering diameter output	D5	g7	60 (2.362)	70 (2.756)	90 (3.543)	130 (5.118)				
Diagonal dimension output	D7		92 (3.622)	100 (3.937)	140 (5.512)	185 (7.283)				
Max. diameter	D9		86 (3.386)	105 (4.134)	120 (4.724)	170 (6.693)				
Flange cross section output	Q1	■	70 (2.756)	80 (3.150)	110 (4.331)	142 (5.591)				
Housing length	L2		46.5 (1.831)	60.5 (2.382)	73.5 (2.894)	76 (2.992)				
Shaft length output	L3		33 (1.299)	34.5 (1.358)	48 (1.890)	54 (2.126)				
Centering depth output	L7		18 (0.709)	17.5 (0.689)	27 (1.063)	28 (1.102)				
Flange thickness output	L8		7 (0.276)	8 (0.315)	10 (0.394)	12 (0.472)				
Offset length	L9		43 (1.693)	48.5 (1.909)	56.5 (2.224)	87 (3.425)	1			
Min. overall height	L23		179 (7.047)	204 (8.012)	248 (9.744)	318 (12.520)				
Max. radius	R		1.5 (0.059)	1.5 (0.059)	1.5 (0.059)	1.5 (0.059)				
Clamping system diameter input	D26		More information on page 131							
Motor shaft diameter j6/k6	D20		The dimensions vary with the motor/gearbox flange. The input flange dimensions can be retrieved for each specific motor in Tec Data Finder at www.neugart.com							
Max. permis. motor shaft length	L20									
Min. permis. motor shaft length										
Centering diameter input	D21									
Centering depth input	L21									
Pitch circle diameter input	D22									
Motor flange length	L22									
Diagonal dimension input	D23									
Mounting thread x depth	G3	4x								
Flange cross section input	Q3	■								
Hollow output shaft on one side										
Hollow shaft diameter	D24	H6	15 (0.591)	20 (0.787)	30 (1.181)	40 (1.575)		F		
Total length	L1		122.5 (4.823)	143.5 (5.650)	178 (7.008)	217 (8.543)				
Shaft length from shoulder	L4		14 (0.551)	16 (0.630)	20 (0.787)	25 (0.984)				
Min. fit length	L24		20 (0.787)	25 (0.984)	30 (1.181)	35 (1.378)				
Hollow output shaft on both sides										
Hollow shaft diameter	D24	H6	15 (0.591)	20 (0.787)	30 (1.181)	40 (1.575)		G		
Shaft collar	D25		25 (0.984)	30 (1.181)	42 (1.654)	55 (2.165)				
Total length	L1		137.5 (5.413)	160.5 (6.319)	199 (7.835)	243 (9.567)				
Shaft length from shoulder	L4		14 (0.551)	16 (0.630)	20 (0.787)	25 (0.984)				
Min. fit length	L24		20 (0.787)	25 (0.984)	30 (1.181)	35 (1.378)				

⁽¹⁾ Dimensions in mm (in)

⁽²⁾ Number of stages

