



WPLPE

The economical right angle planetary gearbox for particularly high forces – flexible installation options and lifetime lubrication

The **WPLPE** is the sought-after angle solution from our Economy range: space-saving yet powerful at an attractive price. You attach your drive elements directly to the output shaft, which can also withstand high radial forces thanks to extra-strong deep groove ball bearings.

Cyclic torque **5 - 195 Nm**



Radial force **1300 - 4000 N**



Axial force **1000 - 5900 N**



Torsional backlash **11 - 25 arcmin**



Protection class **IP54**



Baugrößen
Frame sizes

- 50
- 70
- 90
- 120



Economy Line



Right angle gearbox



Spur gear



Round type output flange



Reinforced deep groove ball bearings

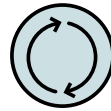

Equidirectional rotation

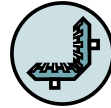

Bevel gear right angle stage



Reinforced deep groove ball bearings



Option: Painted surface
– RAL 9005 Jet black

Detailed explanations of the technical features starting on page 201.

Code	Gearbox characteristics			WPLPE050	WPLPE070	WPLPE090	WPLPE120	p ⁽¹⁾
	Service life ⁽²⁾	L _h	h	20,000				
	Efficiency ⁽³⁾	η	%	95				1
				94				2
	Min. operating temperature	T _{min}	°C	-25 (-13)				
	Max. operating temperature	T _{max}	(°F)	90 (194)				
	Protection class			IP54				
S	Standard lubrication			Grease (lifetime lubrication)				
F	Food grade lubrication			Grease (lifetime lubrication)				
	Installation position			Any				
S	Standard backlash	φ	arcmin	< 21	< 16	< 13	< 11	1
				< 25	< 18	< 15	< 13	2
	Torsional stiffness ⁽³⁾	C _{2t}	Nm / arcmin (lb _f .in/ arcmin)	0.5 - 0.8 (4 - 7)	2.2 - 4.1 (19 - 36)	4.7 - 10.8 (42 - 96)	13.1 - 28.0 (116 - 248)	1
				0.7 - 1.1 (6 - 9)	3.3 - 5.7 (29 - 50)	9.7 - 15.7 (86 - 139)	21.0 - 42.5 (186 - 376)	2
	Gearbox weight ⁽³⁾	m	kg (lb _m)	0.8 (1.8 - 1.9)	2.1 - 2.2 (4.7)	4.8 (10.5 - 10.7)	11.4 - 11.5 (25.1 - 25.4)	1
				1.0 - 1.3 (2.2 - 2.9)	2.4 - 2.6 (5.3 - 5.7)	5.4 - 5.6 (12.0 - 12.3)	13.3 - 13.6 (29.4 - 30.1)	2
S	Standard surface			Housing: Steel – heat-treated and post-oxidized (black)				
B	Painted surface ⁽⁴⁾			RAL 9005 Jet black				
	Running noise ⁽³⁾	L _{pA}	dB(A)	68	70	73	75	

Output shaft loads			WPLPE050	WPLPE070	WPLPE090	WPLPE120	p ⁽¹⁾
Maximum radial force	F _{r max}	N (lb _f)	1300 (292)	1500 (337)	3100 (697)	4000 (899)	
Maximum axial force	F _{a max}		1000 (225)	2000 (450)	3800 (854)	5900 (1326)	
Maximum tilting moment	M _{K max}	Nm (lb _f .in)	42 (369)	61 (537)	162 (1429)	268 (2372)	

Input characteristics			WPLPE050	WPLPE070	WPLPE090	WPLPE120	p ⁽¹⁾
Clamping system diameter input (Code)	D26	mm	8 (A)	11 (C)	19 (E) ⁽⁵⁾	24 (F) ⁽⁵⁾	
			9 (B) ⁽⁵⁾	14 (D) ⁽⁵⁾	-	-	
Mass moment of inertia input ⁽³⁾⁽⁵⁾	J ₁	kgcm ² (lb _f .in.s ² 10 ⁻⁴)	0.040 - 0.060 (0.354 - 0.531)	0.224 - 0.336 (1.983 - 2.974)	0.877 - 1.361 (7.762 - 12.046)	2.686 - 4.073 (23.773 - 36.049)	1
			0.040 - 0.057 (0.354 - 0.504)	0.224 - 0.333 (1.983 - 2.947)	0.859 - 1.197 (7.603 - 10.594)	2.643 - 3.643 (23.393 - 32.243)	2
Average idle torque ⁽³⁾⁽⁵⁾	T ₀	Nm (lb _f .in)	0.05 (0)	0.15 - 0.20 (1 - 2)	0.25 - 0.65 (2 - 6)	0.85 - 1.55 (8 - 14)	1
			0.05 (0)	0.15 - 0.20 (1 - 2)	0.25 - 0.60 (2 - 5)	0.80 - 1.55 (7 - 14)	2
Max. bending moment based on the gearbox input flange	M _{b1}		2 (18)	5 (44)	10.5 (93)	26 (230)	

⁽¹⁾ Number of stages

⁽²⁾ Application specific configuration with NCP – www.neugart.com

⁽³⁾ The ratio-dependent values can be retrieved in Tec Data Finder – www.neugart.com

⁽⁴⁾ More information on page 183

⁽⁵⁾ Reference clamping system diameter

Output torques			WPLPE050	WPLPE070	WPLPE090	WPLPE120	i ⁽¹⁾	p ⁽²⁾		
Cyclic torque ⁽³⁾	T _{2z}	Nm (lb _r .in)	4.5 (40)	14 (124)	40 (354)	78 (690)	3	1		
			6 (53)	19 (168)	53 (469)	104 (920)	4			
			7.5 (66)	24 (212)	67 (593)	130 (1151)	5			
			8.5 (75)	25 (221)	65 (575)	135 (1195)	7			
			6 (53)	18 (159)	50 (443)	120 (1062)	8			
			5 (44)	15 (133)	38 (336)	95 (841)	10			
			12 (106)	33 (292)	97 (859)	157 (1390)	9			
			15 (133)	33 (292)	90 (797)	195 (1726)	12			
				Nm (lb _r .in)	13 (115)	33 (292)	82 (726)	172 (1522)	15	2
					15 (133)	33 (292)	90 (797)	195 (1726)	16	
					15 (133)	33 (292)	90 (797)	195 (1726)	20	
					13 (115)	30 (266)	82 (726)	172 (1522)	25	
					15 (133)	33 (292)	90 (797)	195 (1726)	32	
					13 (115)	30 (266)	82 (726)	172 (1522)	40	
					7.5 (66)	18 (159)	50 (443)	120 (1062)	64	
					5 (44)	15 (133)	38 (336)	95 (841)	100	
Maximum torque ⁽³⁾	T _{2max}	Nm (lb _r .in)	7 (62)	23 (204)	64 (566)	124 (1097)	3	1		
			9.5 (84)	30 (266)	85 (752)	166 (1469)	4			
			12 (106)	38 (336)	107 (947)	205 (1814)	5			
			13.5 (119)	40 (354)	104 (920)	215 (1903)	7			
			9.5 (84)	28 (248)	80 (708)	192 (1699)	8			
			8 (71)	24 (212)	60 (531)	152 (1345)	10			
			14.5 (128)	52 (460)	146 (1292)	250 (2213)	9			
			24 (212)	48 (425)	144 (1275)	310 (2744)	12			
				Nm (lb _r .in)	20 (177)	52 (460)	131 (1159)	275 (2434)	15	2
					24 (212)	48 (425)	144 (1275)	310 (2744)	16	
					24 (212)	48 (425)	144 (1275)	310 (2744)	20	
					24 (212)	48 (425)	144 (1275)	310 (2744)	25	
					24 (212)	48 (425)	144 (1275)	310 (2744)	32	
					20 (177)	46 (407)	131 (1159)	275 (2434)	40	
					12 (106)	28 (248)	80 (708)	192 (1699)	64	
					8 (71)	24 (212)	60 (531)	152 (1345)	100	

WPLPE

⁽¹⁾ Ratios (i=n₁/n₂)
⁽²⁾ Number of stages
⁽³⁾ Application specific configuration with NCP – www.neugart.com

Output torques			WPLPE050	WPLPE070	WPLPE090	WPLPE120	$i^{(1)}$	$p^{(2)}$
Continuous torque ⁽³⁾	T_{2D}	Nm (lb _f .in)	1.5 (13)	6 (53)	13.5 (119)	32 (283)	3	1
			2.5 (22)	8.5 (75)	18 (159)	43 (381)	4	
			3 (27)	10.5 (93)	22 (195)	53 (469)	5	
			4.5 (40)	15 (133)	32 (283)	75 (664)	7	
			5 (44)	15 (133)	36 (319)	86 (761)	8	
			4 (35)	12.5 (111)	32 (283)	80 (708)	10	
		5 (44)	19 (168)	41 (363)	98 (867)	9	2	
		7.5 (66)	24 (212)	55 (487)	129 (1142)	12		
		9.5 (84)	25 (221)	68 (602)	146 (1292)	15		
		10 (89)	26 (230)	73 (646)	165 (1460)	16		
		12.5 (111)	25 (221)	69 (611)	165 (1460)	20		
		11 (97)	25 (221)	69 (611)	146 (1292)	25		
		12.5 (111)	15 (133)	42 (372)	165 (1460)	32		
		11 (97)	15 (133)	42 (372)	146 (1292)	40		
		6 (53)	15 (133)	42 (372)	102 (903)	64		
		4 (35)	12.5 (111)	32 (283)	80 (708)	100		

Input speeds			WPLPE050	WPLPE070	WPLPE090	WPLPE120	$i^{(1)}$	$p^{(2)}$
Continuous input speed ⁽³⁾⁽⁴⁾	n_{1D}	rpm	5000	4500	4000	3500	3	1
			5000	4500	4000	3500	4	
			5000	4500	4000	3500	5	
			5000	4500	4000	3500	7	
			5000	4500	4000	3500	8	
			5000	4500	4000	3500	10	
		5000	4500	4000	3300	9	2	
		5000	4500	4000	3500	12		
		5000	4500	4000	3500	15		
		5000	4500	4000	3500	16		
		5000	4500	4000	3500	20		
		5000	4500	4000	3500	25		
		5000	4500	4000	3500	32		
		5000	4500	4000	3500	40		
		5000	4500	4000	3500	64		
		5000	4500	4000	3500	100		
Max. mechanical input speed ⁽³⁾	n_{1max}	rpm	18000	13000	7000	6500		

Output torques			WPLPE050	WPLPE070	WPLPE090	WPLPE120	$i^{(1)}$	$p^{(2)}$
Emergency stop torque ⁽⁴⁾⁽⁵⁾	T_{2Stop}	Nm (lb _f .in)	12 (106)	60 (531)	135 (1195)	300 (2655)	3	1
			16 (142)	80 (708)	180 (1593)	400 (3540)	4	
			20 (177)	80 (708)	220 (1947)	500 (4425)	5	
			26 (230)	80 (708)	178 (1575)	340 (3009)	7	
			27 (239)	80 (708)	190 (1682)	380 (3363)	8	
			25 (221)	70 (620)	170 (1505)	430 (3806)	10	
		33 (292)	88 (779)	260 (2301)	500 (4425)	9	2	
		40 (354)	88 (779)	240 (2124)	520 (4602)	12		
		36 (319)	88 (779)	220 (1947)	500 (4425)	15		
		40 (354)	88 (779)	240 (2124)	520 (4602)	16		
		40 (354)	88 (779)	240 (2124)	520 (4602)	20		
		36 (319)	80 (708)	220 (1947)	500 (4425)	25		
		40 (354)	88 (779)	205 (1814)	520 (4602)	32		
		36 (319)	80 (708)	205 (1814)	500 (4425)	40		
		27 (239)	80 (708)	190 (1682)	380 (3363)	64		
		27 (239)	75 (664)	170 (1505)	430 (3806)	100		

(1) Ratios ($i=n_1/n_2$)
 (2) Number of stages
 (3) Application specific configuration with NCP – www.neugart.com
 (4) Based on reference clamping system diameter
 (5) Permitted 1000 times

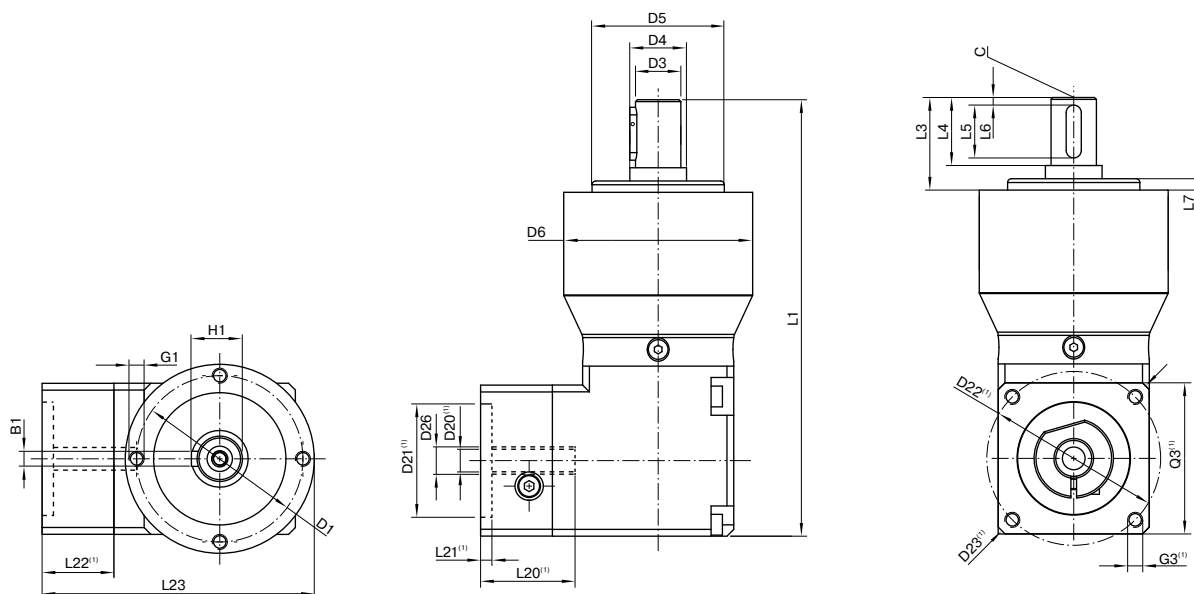

Drawing corresponds to a WPLPE090 / 1-stage / output shaft with feather key / 19 mm clamping system / motor adaptation – 2-part – square universal flange / B5 flange type motor

⁽¹⁾ The dimensions vary with the motor/gearbox flange. The input flange dimensions can be retrieved for each specific motor in Tec Data Finder at www.neugart.com

Geometry ⁽²⁾			WPLPE050	WPLPE070	WPLPE090	WPLPE120	p ⁽³⁾	Code
Pitch circle diameter output	D1		44 (1.732)	62 (2.441)	80 (3.150)	108 (4.252)		
Shaft diameter output	D3	k7	12 (0.472)	16 (0.630)	22 (0.866)	32 (1.260)		
Shaft collar output	D4		15 (0.591)	30 (1.181)	35 (1.378)	50 (1.969)		
Centering diameter output	D5	h7	35 (1.378)	52 (2.047)	68 (2.677)	90 (3.543)		
Housing diameter	D6		50 (1.969)	70 (2.756)	90 (3.543)	120 (4.724)		
Mounting thread x depth	G1	4x	M4x8	M5x8	M6x9	M8x20		
Total length	L1		115.5 (4.547)	152.5 (6.004)	197.5 (7.776)	265 (10.433)	1	
			128 (5.039)	165.5 (6.516)	215.5 (8.484)	292.5 (11.516)	2	
Shaft length output	L3		24.5 (0.965)	36 (1.417)	46 (1.811)	68 (2.677)		
Centering depth output	L7		3 (0.118)	3 (0.118)	4 (0.157)	5 (0.197)		
Min. overall height	L23		72 (2.835)	90.5 (3.563)	114.5 (4.508)	148 (5.827)		
Motor shaft diameter j6/k6	D20		More information on page 191/192					
Clamping system diameter input	D26		More information on page 76					
Output shaft with feather key (DIN 6885-1)			A 4x4x14	A 5x5x25	A 6x6x32	A 10x8x50		A
Feather key width (DIN 6885-1)	B1		4 (0.157)	5 (0.197)	6 (0.236)	10 (0.394)		
Shaft height including feather key (DIN 6885-1)	H1		13.5 (0.531)	18 (0.709)	24,5 (0.965)	35 (1.378)		
Shaft length from shoulder	L4		18 (0.709)	28 (1.102)	36 (1.417)	58 (2.283)		
Feather key length	L5		14 (0.551)	25 (0.984)	32 (1.260)	50 (1.969)		
Distance from shaft end	L6		2 (0.079)	2 (0.079)	2 (0.079)	4 (0.157)		
Center hole (DIN 332, type DR)	C		M4x10	M5x12,5	M8x19	M12x28		
Smooth output shaft								B
Shaft length from shoulder	L4		18 (0.709)	28 (1.102)	36 (1.417)	58 (2.283)		

⁽²⁾ Dimensions in mm

⁽³⁾ Number of stages