



# PSN

## Das schrägverzahnte Präzisionsgetriebe mit geräuscharmem Gleichlauf für hohe Lagerbelastungen

Unser **PSN** ist Fortschritt pur: Seine Schrägverzahnung ermöglicht einen geräuscharmen Gleichlauf. Mit diesem Präzisions-Planetengetriebe werden Vibrationen auf ein Minimum reduziert. Präzision auch bei sehr hohe Belastung machen das **PSN** zu einem der leistungsfähigsten Getriebe weltweit.

## The helical precision planetary gearbox for low-noise operation and high bearing loads

Our **PSN** is pure progress: Its helical gearing ensures low-noise synchronization. With this precision planetary gearbox, vibrations are reduced to a minimum. Precision even under very high loads makes the **PSN** one of the most high-performance gearboxes in the world.

Zyklusdrehmoment Cyclic torque	<b>14 - 950 Nm</b>
Radialkraft Radial force	<b>950 - 20000 N</b>
Axialkraft Axial force	<b>2200 - 17000 N</b>
Verdrehspiel Torsional backlash	<b>1 - 8 arcmin</b>
Schutzart Protection class	<b>IP65</b>

### Baugrößen Frame sizes

- 55
- 70
- 90
- 115
- 142
- 190

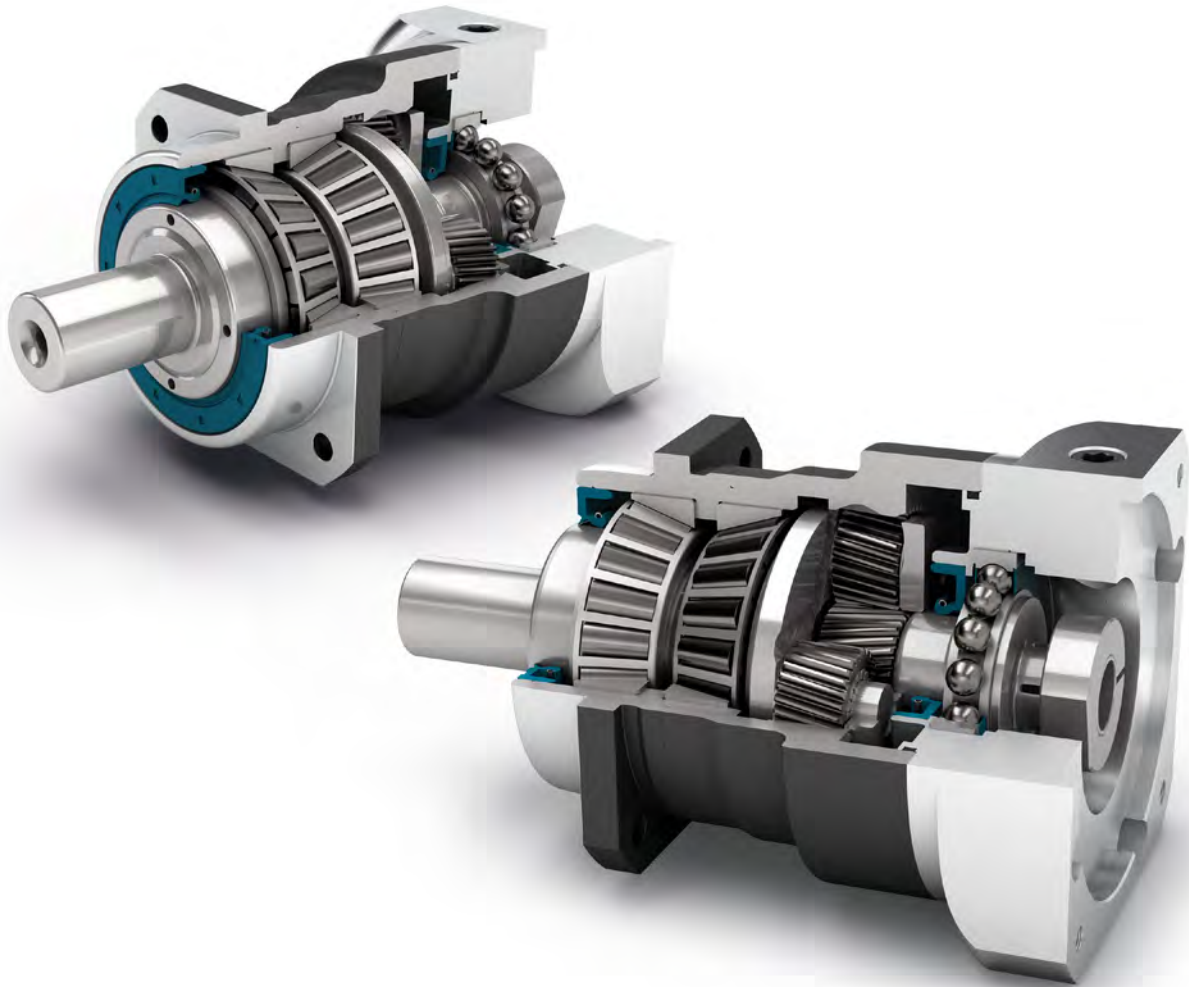

Precision Line  
Precision Line



Schrägverzahnt  
Helical gear



Vorgespannte Kegelrollenlager  
Preloaded tapered roller bearings



Extra langer Zentrierbund am Abtrieb  
Extra long centering collar



Option: Reduziertes Verdrehspiel  
Option: Reduced backlash



Option: Ritzel-Zahnstange  
Planetengetriebe (Details auf Seite 158)  
Option: Rack and pinion  
Planetary gearbox (Details on page 158)

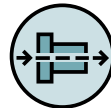

Koaxialgetriebe  
Coaxial gearbox

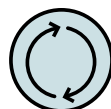

Drehrichtung gleichsinnig  
Equidirectional rotation

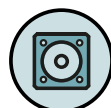

Quadratischer Abtriebsflansch  
Square type output flange



Radialwellendichtring  
Rotary shaft seal



Planetenträger in Käfigausführung  
Planet carrier in cage design



Option: Lackierte Oberfläche  
– RAL 9005 Tiefschwarz  
Option: Painted surface  
– RAL 9005 Jet black

Detaillierte Erläuterungen der technischen Features ab Seite 201.  
Detailed explanations of the technical features starting on page 201.

Code	Getriebekennwerte	Gearbox characteristics			PSN055	PSN070	PSN090	PSN115	PSN142	PSN190	p <sup>(1)</sup>
	Lebensdauer <sup>(2)</sup>	Service life <sup>(2)</sup>	L <sub>n</sub>	h	20.000						
	Wirkungsgrad <sup>(3)</sup>	Efficiency <sup>(3)</sup>	η	%	98						1
					97						2
	Betriebstemperatur min.	Min. operating temperature	T <sub>min</sub>	°C	-25						
	Betriebstemperatur max.	Max. operating temperature	T <sub>max</sub>		90						
	Schutzart	Protection class			IP65						
S	Standard Schmierung	Standard lubrication			Öl (lebensdauer geschmiert) / Oil (lifetime lubrication)						
F	Lebensmitteltaugliche Schmierung	Food grade lubrication			Öl (lebensdauer geschmiert) / Oil (lifetime lubrication)						
	Einbaulage	Installation position			Beliebig / Any						
S	Standard Verdrehspiel	Standard backlash	φ	arcmin	< 6	< 3	< 3	< 3	< 3	< 3	1
					< 8	< 5	< 5	< 5	< 5	< 5	< 5
R	Reduziertes Verdrehspiel	Reduced backlash			< 4	< 2	< 1	< 1	< 1	< 1	1
					< 6	< 2	< 1	< 1	< 1	< 1	2
	Verdrehsteifigkeit <sup>(3)</sup>	Torsional stiffness <sup>(3)</sup>	C <sub>2t</sub>	Nm / arcmin	1,3 - 1,9	3,6 - 5,0	10,5 - 13,9	28,0 - 39,0	62,0 - 88,0	181,0 - 246,0	1
					1,3 - 1,9	3,6 - 5,0	10,3 - 13,8	28,5 - 39,5	61,0 - 86,0	179,0 - 255,0	2
	Getriebegewicht <sup>(3)</sup>	Gearbox weight <sup>(3)</sup>	m	kg	0,8	2,2	4,0 - 4,1	6,9 - 7,3	15,1 - 15,5	34,5 - 36,3	1
					1,1	2,8 - 2,9	4,2	8,4 - 8,6	16,7 - 17,3	38,6 - 40,5	2
S	Standard Oberfläche	Standard surface			Gehäuse: Stahl – wärmebehandelt und nachoxidiert (schwarz) Housing: Steel – heat-treated and post-oxidized (black)						
B	Lackierte Oberfläche <sup>(4)</sup>	Painted surface <sup>(4)</sup>			RAL 9005 Tiefschwarz RAL 9005 Jet black						
	Laufgeräusch <sup>(3)</sup>	Running noise <sup>(3)</sup>	L <sub>pA</sub>	dB(A)	56	57	58	63	66	68	

Abtriebswellenbelastungen	Output shaft loads			PSN055	PSN070	PSN090	PSN115	PSN142	PSN190	p <sup>(1)</sup>
Maximale Radialkraft	Maximum radial force	F <sub>r max</sub>	N	950	3200	5500	6000	13000	20000	
Maximale Axialkraft	Maximum axial force	F <sub>a max</sub>		2200	3400	4500	6500	12000	17000	
Maximales Kippmoment	Maximum tilting moment	M <sub>K max</sub>	Nm	40	203	419	562	1566	2887	

Antriebskennwerte	Input characteristics			PSN055	PSN070	PSN090	PSN115	PSN142	PSN190	p <sup>(1)</sup>				
Durchmesser Spannsystem am Antrieb (Code)	Clamping system diameter input (Code)	D26	mm	11 (C) <sup>(5)</sup>	11 (C)	14 (D)	19 (E)	35 (G) <sup>(5)</sup>	48 (K) <sup>(5)</sup>	1				
				14 (D)	14 (D) <sup>(5)</sup>	19 (E) <sup>(5)</sup>	24 (F) <sup>(5)</sup>	42 (H)	-					
				-	19 (E)	24 (F)	35 (G)	-	-					
								11 (C) <sup>(5)</sup>	11 (C)	11 (C)	14 (D)	19 (E)	35 (G) <sup>(5)</sup>	2
								14 (D)	14 (D) <sup>(5)</sup>	14 (D) <sup>(5)</sup>	19 (E) <sup>(5)</sup>	24 (F) <sup>(5)</sup>	42 (H)	
				-	19 (E)	19 (E)	24 (F)	35 (G)	-					
Massenträgheitsmoment Antrieb <sup>(3)(5)</sup>	Mass moment of inertia input <sup>(3)(5)</sup>	J <sub>i</sub>	kgcm <sup>2</sup>	0,096	0,150	0,439	1,147	6,475	21,695	1				
				-	-	-	-	-	-					
				0,126	0,294	0,920	2,775	13,112	53,182					
				0,095	0,146	0,146	0,431	1,131	6,360	2				
				-	-	-	-	-	-					
				0,109	0,199	0,227	0,710	2,252	10,654					
Mittleres Leerlaufdrehmoment <sup>(3)(5)</sup>	Average idle torque <sup>(3)(5)</sup>	T <sub>0</sub>	Nm	0,15	0,20	0,40	0,75	2,05	4,30	1				
				-	-	-	-	-	-					
				0,30	0,65	1,25	2,70	9,60	20,30					
								0,15	0,15	0,25	0,40	0,70	1,75	2
								0,25	0,45	0,55	1,35	3,40	7,30	
Max. Biegemoment bezogen auf den Getriebeantriebsflansch	Max. bending moment based on the gearbox input flange	M <sub>b1</sub>		10	18	38	80	180	300	1				
				10	18	18	38	80	180	2				

(1) Anzahl Getriebestufen

(2) Applikationsspezifische Auslegung mit NCP – www.neugart.com

(3) Die übersetzungsabhängigen Werte sind im Tec Data Finder abrufbar – www.neugart.com

(4) Weitere Informationen auf Seite 183

(5) Referenz Spannsystemdurchmesser

(1) Number of stages

(2) Application specific configuration with NCP – www.neugart.com

(3) The ratio-dependent values can be retrieved in Tec Data Finder – www.neugart.com

(4) More information on page 183

(5) Reference clamping system diameter

Abtriebsdrehmomente	Output torques			PSN055	PSN070	PSN090	PSN115	PSN142	PSN190	i <sup>(1)</sup>	p <sup>(2)</sup>
Zyklusdrehmoment <sup>(3)(4)</sup>	Cyclic torque <sup>(3)(4)</sup>	T <sub>2z</sub>	Nm	16	29	54	135	380	840	3	1
				18	39	80	180	470	950	4	
				18	40	80	175	405	950	5	
				18	37	78	175	355	900	7	
				18	39	75	155	350	-	8	
				13,5	28	59	140	305	750	10	
				16	29	54	135	380	840	12	
				16	29	54	135	380	840	15	
				18	39	80	180	470	950	16	
				18	39	80	180	470	950	20	
				18	40	80	175	405	950	25	
				18	40	80	175	405	950	35	
				18	39	80	180	470	950	40	
				18	40	80	175	405	950	50	
18	37	78	175	355	900	70					
13,5	28	59	140	305	750	100					
Maximales Drehmoment <sup>(3)(4)</sup>	Maximum torque <sup>(3)(4)</sup>	T <sub>2max</sub>	Nm	25	46	86	215	520	1110	3	1
				28	62	128	285	700	1480	4	
				28	64	128	280	640	1520	5	
				28	58	124	280	560	1440	7	
				28	62	120	245	480	-	8	
				21	44	94	220	485	1050	10	
				25	46	86	215	600	1350	12	
				25	46	86	215	600	1350	15	
				28	62	128	285	750	1520	16	
				28	62	128	285	750	1520	20	
				28	64	128	280	640	1520	25	
				28	64	128	280	640	1520	35	
				28	62	128	285	750	1520	40	
				28	64	128	280	640	1520	50	
28	50	124	280	560	1440	70					
21	44	94	220	485	1050	100					

<sup>(1)</sup> Übersetzungen (i=n<sub>1</sub>/n<sub>2</sub>)

<sup>(2)</sup> Anzahl Getriebestufen

<sup>(3)</sup> Applikationsspezifische Auslegung mit NCP – www.neugart.com

<sup>(4)</sup> Bezogen auf Referenz Spannsystemdurchmesser

<sup>(1)</sup> Ratios (i=n<sub>1</sub>/n<sub>2</sub>)

<sup>(2)</sup> Number of stages

<sup>(3)</sup> Application specific configuration with NCP – www.neugart.com

<sup>(4)</sup> Based on reference clamping system diameter

Abtriebsdrehmomente	Output torques			PSN055	PSN070	PSN090	PSN115	PSN142	PSN190	i <sup>(1)</sup>	p <sup>(2)</sup>		
Dauerdrehmoment <sup>(3)</sup>	Continuous torque <sup>(3)</sup>	T <sub>2D</sub>	Nm	11	24	45	114	320	710	3	1		
				15	33	68	153	395	800	4			
				15	34	68	148	340	800	5			
				15	31	66	148	300	760	7			
				15	33	63	131	295	-	8			
				11	23	50	119	255	630	10			
				13,5	24	45	114	320	710	12			
				13,5	24	45	114	320	710	15			
						15	33	68	153	395	800	16	2
						15	33	68	153	395	800	20	
						15	34	68	148	340	800	25	
						15	34	68	148	340	800	35	
						15	33	68	153	395	800	40	
						15	34	68	148	340	800	50	
						15	31	66	148	300	760	70	
						11	23	50	119	255	630	100	

Antriebsdrehzahlen	Input speeds			PSN055	PSN070	PSN090	PSN115	PSN142	PSN190	i <sup>(1)</sup>	p <sup>(2)</sup>		
Dauerantriebsdrehzahl <sup>(3)(4)</sup>	Continuous input speed <sup>(3)(4)</sup>	n <sub>1D</sub>	min <sup>-1</sup>	4050	2500	2150	1600	1000	610	3	1		
				4150	3150	2150	1750	1050	610	4			
				4950	3800	2600	2200	1500	800	5			
				5000	4500	3450	3200	2200	1100	7			
				5000	4500	3500	3150	2550	-	8			
				5000	4500	4000	3500	3000	1550	10			
				5000	4500	4450	3100	2000	1350	12			
				4500	4500	4500	3850	2500	1750	15			
						5000	4500	4300	3150	2000	1450	16	2
						4600	4500	4500	3900	2500	1900	20	
						5000	4500	4500	4000	3150	2250	25	
						5000	4500	4500	4000	3500	3000	35	
						5000	4500	4500	4000	3500	3000	40	
						5000	4500	4500	4000	3500	3000	50	
						5000	4500	4500	4000	3500	3000	70	
						5000	4500	4500	4000	3500	3000	100	
Max. mechanische Antriebsdrehzahl <sup>(3)</sup>	Max. mechanical input speed <sup>(3)</sup>	n <sub>1max</sub>	min <sup>-1</sup>	10000	10000	10000	8500	6500	6000		1		
				10000	10000	10000	10000	8500	6500		2		

Abtriebsdrehmomente	Output torques			PSN055	PSN070	PSN090	PSN115	PSN142	PSN190	i <sup>(1)</sup>	p <sup>(2)</sup>		
Not-Aus Drehmoment <sup>(4)(5)</sup>	Emergency stop torque <sup>(4)(5)</sup>	T <sub>2Stop</sub>	Nm	48	90	210	490	1050	2220	3	1		
				48	120	280	650	1400	2960	4			
				48	130	280	650	1650	3200	5			
				48	80	175	340	1300	3200	7			
				48	90	200	380	850	-	8			
				24	52	121	295	600	1700	10			
				48	135	220	500	1250	2400	12			
				48	135	220	500	1250	2400	15			
						48	150	300	650	1650	3200	16	2
						48	150	300	650	1650	3200	20	
						48	150	300	650	1650	3200	25	
						48	150	300	650	1650	3200	35	
						48	150	210	485	1180	2680	40	
						48	150	260	600	1480	3200	50	
						48	80	175	340	1300	3200	70	
						24	52	121	295	600	1700	100	

<sup>(1)</sup> Übersetzungen (i=n<sub>1</sub>/n<sub>2</sub>)

<sup>(2)</sup> Anzahl Getriebestufen

<sup>(3)</sup> Applikationsspezifische Auslegung mit NCP – www.neugart.com

<sup>(4)</sup> Bezogen auf Referenz Spannsystemdurchmesser

<sup>(5)</sup> 1000-mal zulässig

<sup>(1)</sup> Ratios (i=n<sub>1</sub>/n<sub>2</sub>)

<sup>(2)</sup> Number of stages

<sup>(3)</sup> Application specific configuration with NCP – www.neugart.com

<sup>(4)</sup> Based on reference clamping system diameter

<sup>(5)</sup> Permitted 1000 times

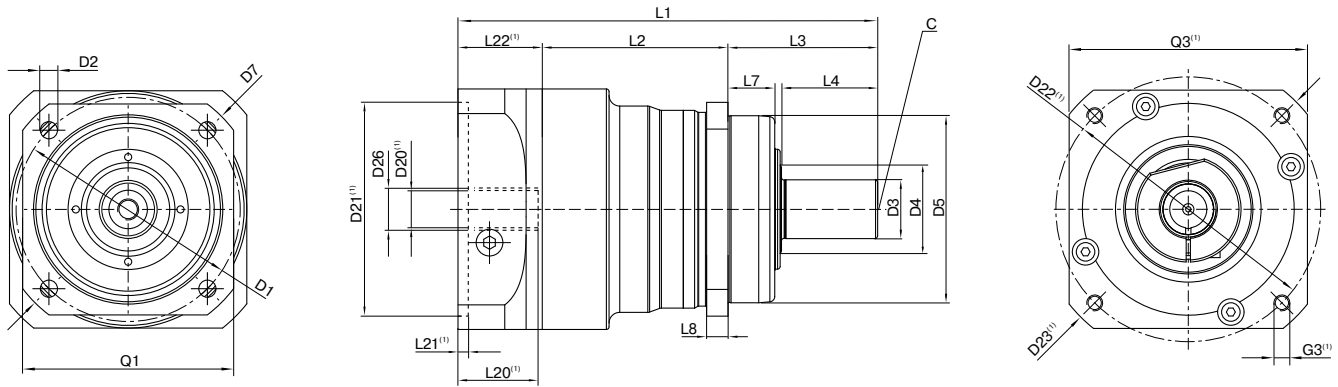

Darstellung entspricht einem PSN090 / 1-stufig / glatte Abtriebswelle / 14 mm Spannsystem / Motoranpassung – 2-teilig – runder Universalfansch / B5 Flanschttyp Motor  
 Drawing corresponds to a PSN090 / 1-stage / smooth output shaft / 14 mm clamping system / motor adaptation – 2-part – round universal flange / B5 flange type motor

<sup>(1)</sup> Die Maße variieren je nach Motor-/Getriebefansch. Die motorspezifischen Antriebsflansch-Geometrien können im Tec Data Finder für jeden Motor gezielt abgerufen werden - www.neugart.com  
<sup>(1)</sup> The dimensions vary with the motor/gearbox flange. The input flange dimensions can be retrieved for each specific motor in Tec Data Finder at www.neugart.com

Geometrie <sup>(2)</sup>	Geometry <sup>(2)</sup>			PSN055	PSN070	PSN090	PSN115	PSN142	PSN190	p <sup>(3)</sup>	Code
Lochkreisdurchmesser Abtrieb	Pitch circle diameter output	D1		63	68 - 75	85	120	165	215		
Montagebohrung Abtrieb	Mounting bore output	D2	4x	5,5	5,5	6,5	9,0	11,0	13,5		
Wellendurchmesser Abtrieb	Shaft diameter output	D3	k6	12	16	22	32	40	55		
Wellenansatz Abtrieb	Shaft collar output	D4		16	21,5	31,5	41,5	57,5	76,5		
Zentrierbunddurchmesser Abtrieb	Centering diameter output	D5	g7	50	60	70	90	130	160		
Diagonalmass Abtrieb	Diagonal dimension output	D7		74	92	100	140	185	240		
Flanschquerschnitt Abtrieb	Flange cross section output	Q1	■	55	70	80	110	142	190		
Min. Gesamtlänge	Min. total length	L1		103,5	134	157	202,5	261,5	310,5	1	
				127	162,5	179	224,5	292,5	355,5	2	
Gehäuselänge	Housing length	L2		43	60,5	69,5	71	101,5	130,5	1	
				66,5	89	98	104,5	139	194	2	
Zentrierbundtiefe Abtrieb	Centering depth output	L7		12	19	17,5	28	28	28		
Flanschdicke Abtrieb	Flange thickness output	L8		6	7	8	10	12	15		
Zentrierbohrung (DIN 332, Form DR)	Center hole (DIN 332, type DR)	C		M4x10	M5x12,5	M8x19	M12x28	M16x36	M20x42		
Durchmesser Motorwelle j6/k6	Motor shaft diameter j6/k6	D20		Weitere Informationen auf Seite 191/192 More information on page 191/192							
Durchmesser Spannsystem am Antrieb	Clamping system diameter input	D26		Weitere Informationen auf Seite 112 More information on page 112							
Abtriebswelle mit Passfeder (DIN 6885-1)	Output shaft with feather key (DIN 6885-1)			A 4x4x18	A 5x5x25	A 6x6x28	A 10x8x50	A 12x8x65	A 16x10x70		
Passfederbreite (DIN 6885-1)	Feather key width (DIN 6885-1)	B1		4	5	6	10	12	16		
Wellenhöhe inklusive Passfeder (DIN 6885-1)	Shaft height including feather key (DIN 6885-1)	H1		13,5	18	24,5	35	43	59		A
Wellenlänge Abtrieb	Shaft length output	L3		36	48	56	88	110	112		
Wellenlänge bis Bund	Shaft length from shoulder	L4		23	28	36	58	80	82		
Passfederlänge	Feather key length	L5		18	25	28	50	65	70		
Abstand vom Wellenende	Distance from shaft end	L6		2	2	4	4	8	6		
Glatte Abtriebswelle	Smooth output shaft										
Wellenlänge Abtrieb	Shaft length output	L3		36	48	56	88	110	112		B
Wellenlänge bis Bund	Shaft length from shoulder	L4		23	28	36	58	80	82		
Verzähnte Abtriebswelle (DIN 5480)	Splined output shaft (DIN 5480)			-	W16x0,8 x18x6m	W22x1,25 x16x6m	W32x1,25 x24x6m	W40x2,0 x18x6m	W55x2,0 x26x6m		
Verzahnungsbreite	Width of gearing	L <sub>v</sub>		-	15	15	15	20	22		C
Wellenlänge Abtrieb	Shaft length output	L3		-	46	46	56	70	71,5		
Wellenlänge bis Bund	Shaft length from shoulder	L4		-	26	26	26	40	41,5		

<sup>(2)</sup> Maße in mm  
<sup>(3)</sup> Anzahl Getriebestufen

<sup>(2)</sup> Dimensions in mm  
<sup>(3)</sup> Number of stages