



PLPE

Das wirtschaftliche Planetengetriebe mit bester Kraft-Wärme-Performance

Unser **PLPE** vereint die besten Eigenschaften der Economy-Baureihe mit einem Plus in der Performance: Das optimierte Abtriebslager ist für höhere Radial- und Axialkräfte ausgelegt. Die kompakte Außenkontur des **PLPE** erlaubt auch den Einsatz bei limitierten Platzverhältnissen.

The cost effective planetary gearbox with the best torque-low heat performance

Our **PLPE** combines the best features of the Economy series with a performance bonus: The optimized output bearing is designed for higher radial and axial forces. The compact outer contour of the **PLPE** also allows it to be used in limited spaces.

Zyklusdrehmoment
Cyclic torque **5- 460 Nm**



Radialkraft
Radial force **1300 - 8400 N**

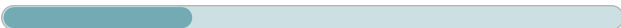

Axialkraft
Axial force **1000 - 11000 N**



Verdrehspiel
Torsional backlash **6 - 19 arcmin**



Schutzart
Protection class **IP54**



Baugrößen
Frame sizes

- 50
- 70
- 90
- 120
- 155

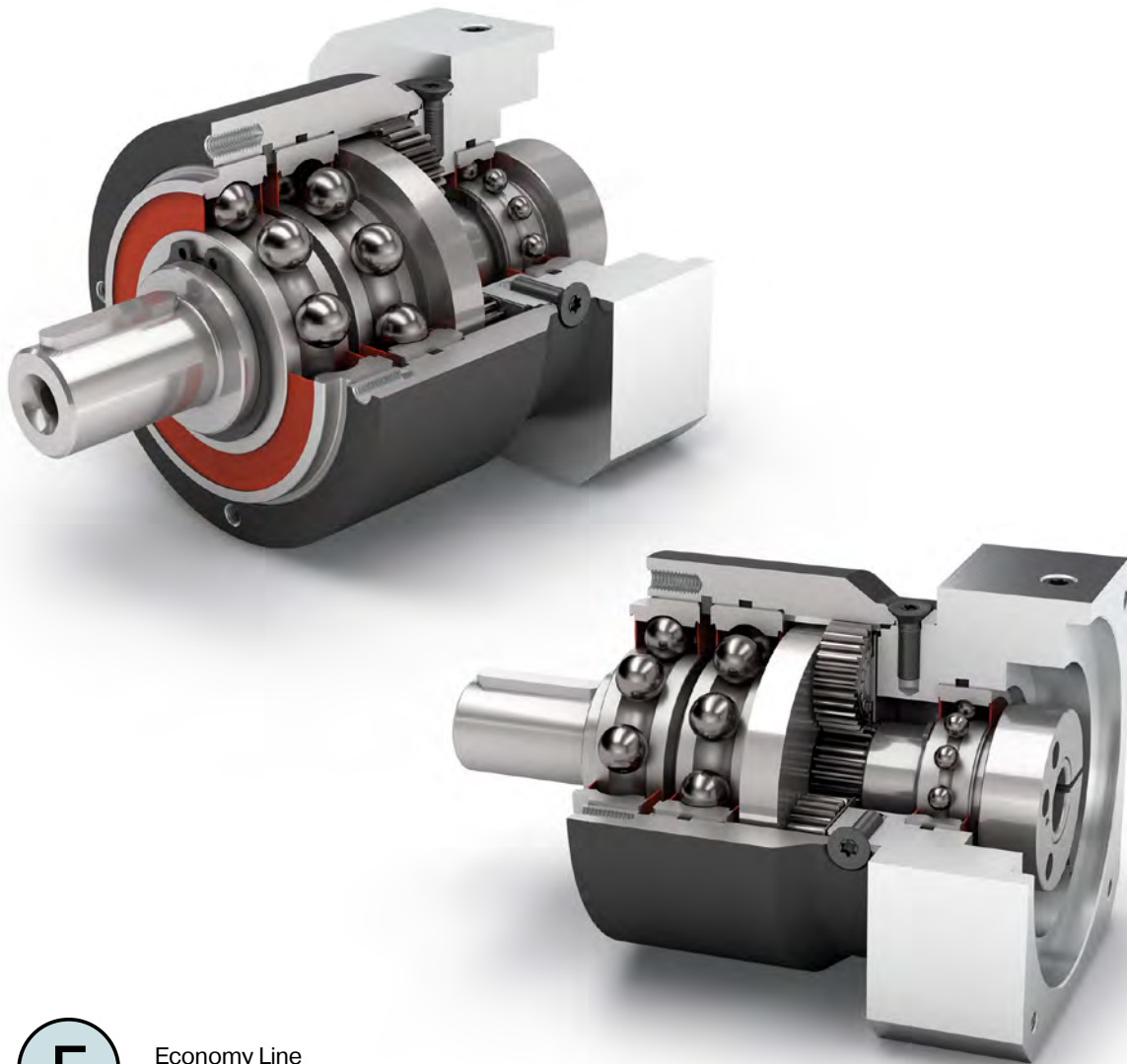

Economy Line
Economy Line



Drehrichtung gleichsinnig
Equidirectional rotation



Runder Abtriebsflansch
Round type output flange



Planetenträger in Scheibenausführung
Planet carrier in disc design



Option: Ritzel-Zahnstange
Planetengetriebe (Details auf Seite 158)
Option: Rack and pinion
Planetary gearbox (Details on page 158)

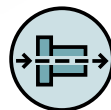

Koaxialgetriebe
Coaxial gearbox



Geradverzahnt
Spur gear



Verstärkte Rillenkugellager
Reinforced deep groove ball bearings



Option: Lackierte Oberfläche
– RAL 9005 Tiefschwarz
Option: Painted surface
– RAL 9005 Jet black

Detaillierte Erläuterungen der technischen Features ab Seite 201.
Detailed explanations of the technical features starting on page 201.

Code	Getriebekennwerte	Gearbox characteristics			PLPE050	PLPE070	PLPE090	PLPE120	PLPE155	p ⁽¹⁾
	Lebensdauer ⁽²⁾	Service life ⁽²⁾	L _n	h	20.000					
	Wirkungsgrad ⁽³⁾	Efficiency ⁽³⁾	η	%	98					1
					97					2
	Betriebstemperatur min.	Min. operating temperature	T _{min}	°C	-25					
	Betriebstemperatur max.	Max. operating temperature	T _{max}		90					
	Schutzart	Protection class			IP54					
S	Standard Schmierung	Standard lubrication			Fett (lebensdauergeschmiert) / Grease (lifetime lubrication)					
F	Lebensmitteltaugliche Schmierung	Food grade lubrication			Fett (lebensdauergeschmiert) / Grease (lifetime lubrication)					
	Einbaulage	Installation position			Beliebig / Any					
S	Standard Verdrehspiel	Standard backlash	φ	arcmin	< 15	< 10	< 7	< 7	< 6	1
					< 19	< 12	< 9	< 9	< 9	2
	Verdrehsteifigkeit ⁽³⁾	Torsional stiffness ⁽³⁾	C _{2t}	Nm / arcmin	0,7 - 1,0	3,5 - 6,6	9,7 - 18,5	24,5 - 52,5	54,5 - 96,0	1
					0,7 - 1,1	3,3 - 7,0	9,7 - 20,0	21,0 - 60,0	55,0 - 100,0	2
	Getriebegewicht ⁽³⁾	Gearbox weight ⁽³⁾	m	kg	0,6	1,4	3,2 - 3,3	7,4 - 7,7	16,7	1
					0,8	1,7 - 1,9	3,9 - 4,1	9,3 - 9,8	21,9 - 22,3	2
S	Standard Oberfläche	Standard surface			Gehäuse: Stahl – wärmebehandelt und nachoxidiert (schwarz) Housing: Steel – heat-treated and post-oxidized (black)					
B	Lackierte Oberfläche ⁽⁴⁾	Painted surface ⁽⁴⁾			RAL 9005 Tiefschwarz RAL 9005 Jet black					
	Laufgeräusch ⁽³⁾	Running noise ⁽³⁾	L _{PA}	dB(A)	58	58	60	65	70	

Abtriebswellenbelastungen	Output shaft loads			PLPE050	PLPE070	PLPE090	PLPE120	PLPE155	p ⁽¹⁾
Maximale Radialkraft	Maximum radial force	F _{r max}	N	1300	1500	3100	4000	8400	
Maximale Axialkraft	Maximum axial force	F _{a max}		1000	2000	3800	5900	11000	
Maximales Kippmoment	Maximum tilting moment	M _{K max}	Nm	42	61	162	268	803	

Antriebskennwerte	Input characteristics			PLPE050	PLPE070	PLPE090	PLPE120	PLPE155	p ⁽¹⁾
Durchmesser Spannsystem am Antrieb (Code)	Clamping system diameter input (Code)	D26	mm	8 (A)	11 (C)	19 (E) ⁽⁵⁾	24 (F) ⁽⁵⁾	35 (G) ⁽⁵⁾	
				9 (B) ⁽⁵⁾	14 (D) ⁽⁵⁾	24 (F)	35 (G)	42 (H)	
				11 (C)	19 (E)	-	-	-	
Massenträgheitsmoment Antrieb ⁽³⁾⁽⁵⁾	Mass moment of inertia input ⁽³⁾⁽⁵⁾	J _i	kgcm ²	0,022	0,090	0,374	1,419	4,932	1
				-	-	-	-	-	
				0,035	0,195	0,789	2,764	7,611	2
				0,022	0,084	0,356	1,376	4,759	
0,032	0,147	0,625	2,334	7,108					
Mittleres Leerlaufdrehmoment ⁽³⁾⁽⁵⁾	Average idle torque ⁽³⁾⁽⁵⁾	T ₀	Nm	0,05 - 0,10	0,15 - 0,40	0,25 - 0,75	0,60 - 1,80	0,75 - 1,70	1
				0,05	0,10 - 0,15	0,15 - 0,30	0,45 - 0,85	0,65 - 1,45	2
Max. Biegemoment bezogen auf den Getriebeantriebsflansch	Max. bending moment based on the gearbox input flange	M _{b1}		4,5	12	16	40	180	

⁽¹⁾ Anzahl Getriebestufen

⁽²⁾ Applikationsspezifische Auslegung mit NCP – www.neugart.com

⁽³⁾ Die übersetzungsabhängigen Werte sind im Tec Data Finder abrufbar – www.neugart.com

⁽⁴⁾ Weitere Informationen auf Seite 183

⁽⁵⁾ Referenz Spannsystemdurchmesser

⁽¹⁾ Number of stages

⁽²⁾ Application specific configuration with NCP – www.neugart.com

⁽³⁾ The ratio-dependent values can be retrieved in Tec Data Finder – www.neugart.com

⁽⁴⁾ More information on page 183

⁽⁵⁾ Reference clamping system diameter

Abtriebsdrehmomente	Output torques			PLPE050	PLPE070	PLPE090	PLPE120	PLPE155	i ⁽¹⁾	p ⁽²⁾
Zyklusdrehmoment ⁽³⁾⁽⁴⁾	Cyclic torque ⁽³⁾⁽⁴⁾	T _{2z}	Nm	11	28	85	115	-	3	1
				15	33	90	155	460	4	
				13	30	82	172	445	5	
				8,5	25	65	135	-	7	
				6	18	50	120	-	8	
				5	15	38	95	210	10	
				12	33	97	157	-	9	
				15	33	90	195	-	12	
				13	33	82	172	-	15	
				15	33	90	195	460	16	
				15	33	90	195	460	20	
				13	30	82	172	445	25	
				15	33	90	195	-	32	
				13	30	82	172	460	40	
				-	-	-	-	445	50	
				7,5	18	50	120	-	64	
				5	15	38	95	210	100	
				Maximales Drehmoment ⁽³⁾⁽⁴⁾	Maximum torque ⁽³⁾⁽⁴⁾	T _{2max}	Nm	11	44	105
24	52	140	245					600	4	
20	48	131	275					710	5	
13,5	40	104	215					-	7	
9,5	28	80	192					-	8	
8	24	60	152					335	10	
14,5	52	155	250					-	9	
24	52	144	310					-	12	
20	52	131	275					-	15	
24	52	144	310					730	16	
24	52	144	310					730	20	
20	48	131	275					710	25	
24	52	144	310					-	32	
20	48	131	275					730	40	
-	-	-	-					710	50	
12	28	80	192					-	64	
8	24	60	152					335	100	

PLPE

⁽¹⁾ Übersetzungen (i=n₁/n₂)

⁽²⁾ Anzahl Getriebestufen

⁽³⁾ Applikationsspezifische Auslegung mit NCP – www.neugart.com

⁽⁴⁾ Bezogen auf Referenz Spannsystemdurchmesser

⁽¹⁾ Ratios (i=n₁/n₂)

⁽²⁾ Number of stages

⁽³⁾ Application specific configuration with NCP – www.neugart.com

⁽⁴⁾ Based on reference clamping system diameter

PLPE

Abtriebsdrehmomente	Output torques			PLPE050	PLPE070	PLPE090	PLPE120	PLPE155	i ⁽¹⁾	p ⁽²⁾
Dauerdrehmoment ⁽³⁾	Continuous torque ⁽³⁾	T _{2D}	Nm	3,5	16,5	37	97	-	3	1
				11	17,5	60	131	390	4	
				11	18	63	146	375	5	
				7	19,5	55	114	-	7	
				5	15	42	102	-	8	
				4	12,5	32	80	178	10	
				5	23	52	133	-	9	2
				12,5	24	76	165	-	12	
				11	26	69	146	-	15	
				12,5	26	76	165	390	16	
				12,5	28	76	165	390	20	
				11	25	69	146	375	25	
				12,5	28	76	165	-	32	
				11	25	69	146	390	40	
				-	-	-	-	375	50	
				6	15	42	102	-	64	
4	12,5	32	80	178	100					

Antriebsdrehzahlen	Input speeds			PLPE050	PLPE070	PLPE090	PLPE120	PLPE155	i ⁽¹⁾	p ⁽²⁾
Dauerantriebsdrehzahl ⁽³⁾⁽⁴⁾	Continuous input speed ⁽³⁾⁽⁴⁾	n _{1D}	min ⁻¹	5000	4500	4000	1550	-	3	1
				5000	4500	4000	1750	1400	4	
				5000	4500	4000	2150	1600	5	
				5000	4500	4000	2800	-	7	
				5000	4500	4000	3500	-	8	
				5000	4500	4000	3500	2700	10	
				5000	4500	4000	2250	-	9	2
				5000	4500	4000	2350	-	12	
				5000	4500	4000	3100	-	15	
				5000	4500	4000	2800	2600	16	
				5000	4500	4000	3400	2950	20	
				5000	4500	4000	3500	3000	25	
				5000	4500	4000	3500	-	32	
				5000	4500	4000	3500	3000	40	
				-	-	-	-	3000	50	
				5000	4500	4000	3500	-	64	
5000	4500	4000	3500	3000	100					
Max. mechanische Antriebsdrehzahl ⁽³⁾	Max. mechanical input speed ⁽³⁾	n _{1max}	min ⁻¹	18000	13000	7000	6500	5500		

Abtriebsdrehmomente	Output torques			PLPE050	PLPE070	PLPE090	PLPE120	PLPE155	i ⁽¹⁾	p ⁽²⁾
Not-Aus Drehmoment ⁽⁴⁾⁽⁵⁾	Emergency stop torque ⁽⁴⁾⁽⁵⁾	T _{2Stop}	Nm	22	60	150	375	-	3	1
				30	80	200	500	920	4	
				36	80	220	500	890	5	
				26	80	178	340	-	7	
				27	80	190	380	-	8	
				27	75	200	480	420	10	
				33	88	260	500	-	9	2
				40	88	240	520	-	12	
				36	88	220	500	-	15	
				40	88	240	520	920	16	
				40	88	240	520	920	20	
				36	80	220	500	890	25	
				40	88	240	520	-	32	
				36	80	220	500	920	40	
				-	-	-	-	890	50	
				27	80	190	380	-	64	
27	75	200	480	420	100					

⁽¹⁾ Übersetzungen (i=n₁/n₂)

⁽²⁾ Anzahl Getriebestufen

⁽³⁾ Applikationsspezifische Auslegung mit NCP – www.neugart.com

⁽⁴⁾ Bezogen auf Referenz Spannsystemdurchmesser

⁽⁵⁾ 1000-mal zulässig

⁽¹⁾ Ratios (i=n₁/n₂)

⁽²⁾ Number of stages

⁽³⁾ Application specific configuration with NCP – www.neugart.com

⁽⁴⁾ Based on reference clamping system diameter

⁽⁵⁾ Permitted 1000 times

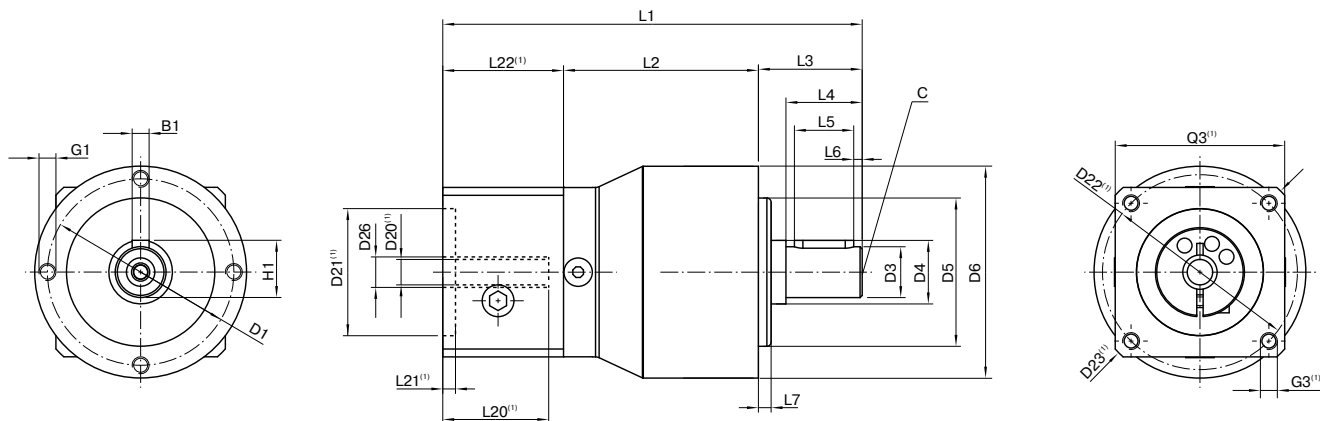

Darstellung entspricht einem PLPE050 / 1-stufig / Abtriebswelle mit Passfeder / 8 mm Spannsystem / Motoranpassung – einteilig / B5 Flanschttyp Motor
 Drawing corresponds to a PLPE050 / 1-stage / output shaft with feather key / 8 mm clamping system / motor adaptation – one part / B5 flange type motor

⁽¹⁾ Die Maße variieren je nach Motor-/Getriebeflansch. Die motorspezifischen Antriebsflansch-Geometrien können im Tec Data Finder für jeden Motor gezielt abgerufen werden - www.neugart.com
⁽¹⁾ The dimensions vary with the motor/gearbox flange. The input flange dimensions can be retrieved for each specific motor in Tec Data Finder at www.neugart.com

Geometrie ⁽²⁾	Geometry ⁽²⁾			PLPE050	PLPE070	PLPE090	PLPE120	PLPE155	p ⁽³⁾	Code
Lochkreisdurchmesser Abtrieb	Pitch circle diameter output	D1		44	62	80	108	140		
Wellendurchmesser Abtrieb	Shaft diameter output	D3	k7	12	16	22	32	40		
Wellenansatz Abtrieb	Shaft collar output	D4		15	30	35	50	55		
Zentrierbunddurchmesser Abtrieb	Centering diameter output	D5	h7	35	52	68	90	120		
Gehäusedurchmesser	Housing diameter	D6		50	70	90	120	155		
Anschraubgewinde x Tiefe	Mounting thread x depth	G1	4x	M4x8	M5x8	M6x9	M8x20	M10x20		
Min. Gesamtlänge	Min. total length	L1		94	111	147	192	275,5	1	
				106,5	124	165	219,5	320	2	
Gehäuselänge	Housing length	L2		46	51	67,5	76,5	100	1	
				58,5	64	85	104	144,5	2	
Wellenlänge Abtrieb	Shaft length output	L3		24,5	36	46	68	97		
Zentrierbundtiefe Abtrieb	Centering depth output	L7		3	3	4	5	8		
Durchmesser Motorwelle j6/k6	Motor shaft diameter j6/k6	D20		Weitere Informationen auf Seite 191/192 More information on page 191/192						
Durchmesser Spannsystem am Antrieb	Clamping system diameter input	D26		Weitere Informationen auf Seite 36 More information on page 36						
Abtriebswelle mit Passfeder (DIN 6885-1)	Output shaft with feather key (DIN 6885-1)			A 4x4x14	A 5x5x25	A 6x6x32	A 10x8x50	A 12x8x70		A
Passfederbreite (DIN 6885-1)	Feather key width (DIN 6885-1)	B1		4	5	6	10	12		
Wellenhöhe inklusive Passfeder (DIN 6885-1)	Shaft height including feather key (DIN 6885-1)	H1		13,5	18	24,5	35	43		
Wellenlänge bis Bund	Shaft length from shoulder	L4		18	28	36	58	82		
Passfederlänge	Feather key length	L5		14	25	32	50	70		
Abstand vom Wellenende	Distance from shaft end	L6		2	2	2	4	6		
Zentrierbohrung (DIN 332, Form DR)	Center hole (DIN 332, type DR)	C		M4x10	M5x12,5	M8x19	M12x28	M16x36		
Glatte Abtriebswelle	Smooth output shaft									B
Wellenlänge bis Bund	Shaft length from shoulder	L4		18	28	36	58	82		

⁽²⁾ Maße in mm
⁽³⁾ Anzahl Getriebestufen

⁽²⁾ Dimensions in mm
⁽³⁾ Number of stages