

# PLHE

**Das ist Fortschritt: Mit diesem Planetengetriebe treffen Präzision und Wirtschaftlichkeit aufeinander**

Das **PLHE** ist unsere ideale Kombination aus Economy- und Präzisionsgetriebe. Die vorgespannten Kegelrollenlager dieses Planetengetriebes garantieren hohe Steifigkeit auch unter höchster Belastung. Die hochperformante Abdichtung ermöglicht erhöhten Schutz gegen Staub und Strahlwasser.

**This is progress: In this planetary gearbox, precision and cost effectiveness meet**

The **PLHE** is our ideal combination of economy and precision gearboxes. The preloaded tapered roller bearings of this planetary gearbox guarantee high rigidity even under maximum load. The high-performance seal provides increased protection against dust and water spray.

Zyklusdrehmoment  
Cyclic torque **15 - 260 Nm**



Radialkraft  
Radial force **3200 - 6000 N**

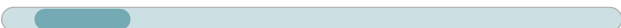

Axialkraft  
Axial force **4400 - 8000 N**

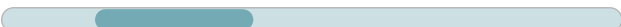

Verdrehspiel  
Torsional backlash **7 - 12 arcmin**

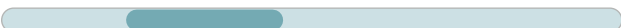

Schutzart  
Protection class **IP65**



Baugrößen  
Frame sizes

- 60
- 80
- 120

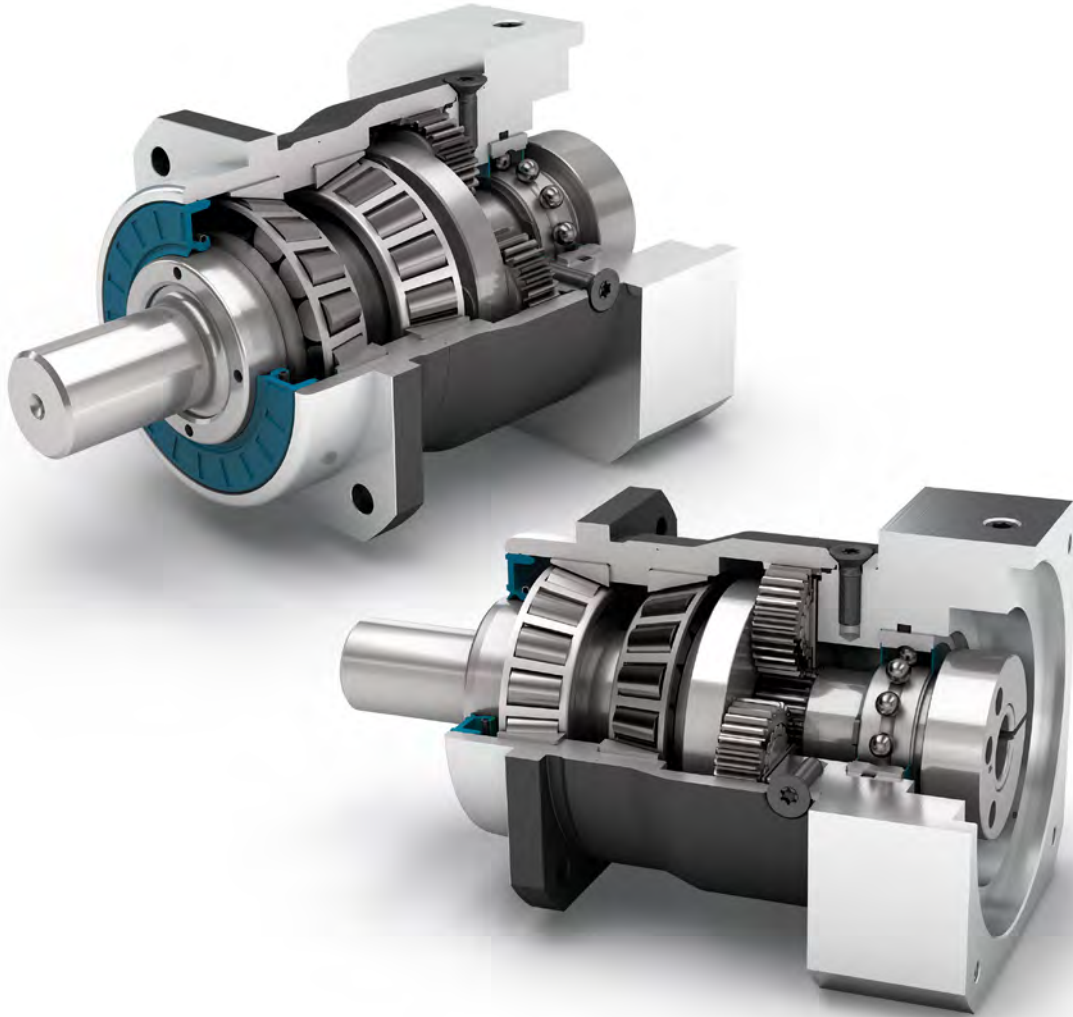

Economy Line  
Economy Line

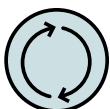

Drehrichtung gleichsinnig  
Equidirectional rotation



Quadratischer Abtriebsflansch  
Square type output flange



Radialwellendichtring  
Rotary shaft seal



Planetenträger in Scheibenausführung  
Planet carrier in disc design

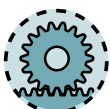

Option: Ritzel-Zahnstange  
Planetengetriebe (Details auf Seite 158)  
Option: Rack and pinion  
Planetary gearbox (Details on page 158)

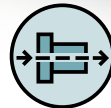

Koaxialgetriebe  
Coaxial gearbox



Geradverzahnt  
Spur gear



Vorgespannte Kegelrollenlager  
Preloaded tapered roller bearings

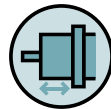

Extra langer Zentrierbund am Abtrieb  
Extra long centering collar



Option: Verzahnte Abtriebswelle (DIN 5480)  
Option: Splined output shaft (DIN 5480)



Option: Lackierte Oberfläche  
– RAL 9005 Tiefschwarz  
Option: Painted surface  
– RAL 9005 Jet black

Detaillierte Erläuterungen der technischen Features ab Seite 201.  
Detailed explanations of the technical features starting on page 201.

Code	Getriebekennwerte	Gearbox characteristics			PLHE060	PLHE080	PLHE120	p <sup>(1)</sup>
	Lebensdauer <sup>(2)</sup>	Service life <sup>(2)</sup>	L <sub>n</sub>	h	20.000			
	Wirkungsgrad <sup>(3)</sup>	Efficiency <sup>(3)</sup>	η	%	97			1
					96			2
	Betriebstemperatur min.	Min. operating temperature	T <sub>min</sub>	°C	-25			
	Betriebstemperatur max.	Max. operating temperature	T <sub>max</sub>		90			
	Schutzart	Protection class		IP65				
<b>S</b>	Standard Schmierung	Standard lubrication		Fett (lebensdauergeschmiert) / Grease (lifetime lubrication)				
<b>F</b>	Lebensmitteltaugliche Schmierung	Food grade lubrication		Fett (lebensdauergeschmiert) / Grease (lifetime lubrication)				
	Einbaulage	Installation position		Beliebig / Any				
<b>S</b>	Standard Verdrehspiel	Standard backlash	φ	arcmin	< 10	< 7	< 7	1
					< 12	< 9	< 9	2
	Verdrehsteifigkeit <sup>(3)</sup>	Torsional stiffness <sup>(3)</sup>	C <sub>2t</sub>	Nm / arcmin	2,6 - 4,4	7,3 - 11,6	18,5 - 26,0	1
					2,5 - 4,6	7,3 - 12,3	16,7 - 27,5	2
	Getriebegewicht <sup>(3)</sup>	Gearbox weight <sup>(3)</sup>	m	kg	1,5 - 1,6	3,0 - 3,1	6,8 - 7,1	1
					1,7 - 1,8	3,5 - 3,6	8,5 - 9,0	2
<b>S</b>	Standard Oberfläche	Standard surface			Gehäuse: Stahl – wärmebehandelt und nachoxidiert (schwarz) Housing: Steel – heat-treated and post-oxidized (black)			
<b>B</b>	Lackierte Oberfläche <sup>(4)</sup>	Painted surface <sup>(4)</sup>			RAL 9005 Tiefschwarz RAL 9005 Jet black			
	Laufgeräusch <sup>(3)</sup>	Running noise <sup>(3)</sup>	L <sub>pA</sub>	dB(A)	58	60	65	

Abtriebswellenbelastungen	Output shaft loads			PLHE060	PLHE080	PLHE120	p <sup>(1)</sup>
Maximale Radialkraft	Maximum radial force	F <sub>r max</sub>	N	3200	5500	6000	
Maximale Axialkraft	Maximum axial force	F <sub>a max</sub>		3400	4500	6500	
Maximales Kippmoment	Maximum tilting moment	M <sub>K max</sub>	Nm	191	383	488	

Antriebskennwerte	Input characteristics			PLHE060	PLHE080	PLHE120	p <sup>(1)</sup>
Durchmesser Spannsystem am Antrieb (Code)	Clamping system diameter input (Code)	D26	mm	11 (C)	19 (E) <sup>(5)</sup>	24 (F) <sup>(5)</sup>	
				14 (D) <sup>(5)</sup>	24 (F)	35 (G)	
				19 (E)	-	-	
Massenträgheitsmoment Antrieb <sup>(3)/(5)</sup>	Mass moment of inertia input <sup>(3)/(5)</sup>	J <sub>1</sub>	kgcm <sup>2</sup>	0,090 - 0,198	0,370 - 0,775	1,390 - 2,486	1
				0,085 - 0,155	0,357 - 0,641	1,378 - 2,326	2
Mittleres Leerlaufdrehmoment <sup>(3)/(5)</sup>	Average idle torque <sup>(3)/(5)</sup>	T <sub>0</sub>	Nm	0,15 - 0,50	0,30 - 0,90	0,65 - 1,75	1
				0,10 - 0,20	0,15 - 0,40	0,45 - 0,95	2
Max. Biegemoment bezogen auf den Getriebeantriebsflansch	Max. bending moment based on the gearbox input flange	M <sub>b1</sub>		8	16	40	

<sup>(1)</sup> Anzahl Getriebestufen

<sup>(2)</sup> Applikationsspezifische Auslegung mit NCP – [www.neugart.com](http://www.neugart.com)

<sup>(3)</sup> Die übersetzungsabhängigen Werte sind im Tec Data Finder abrufbar – [www.neugart.com](http://www.neugart.com)

<sup>(4)</sup> Weitere Informationen auf Seite 183

<sup>(5)</sup> Referenz Spannsystemdurchmesser

<sup>(1)</sup> Number of stages

<sup>(2)</sup> Application specific configuration with NCP – [www.neugart.com](http://www.neugart.com)

<sup>(3)</sup> The ratio-dependent values can be retrieved in Tec Data Finder – [www.neugart.com](http://www.neugart.com)

<sup>(4)</sup> More information on page 183

<sup>(5)</sup> Reference clamping system diameter

Abtriebsdrehmomente	Output torques			PLHE060	PLHE080	PLHE120	i <sup>(1)</sup>	p <sup>(2)</sup>
Zyklusdrehmoment <sup>(3)(4)</sup>	Cyclic torque <sup>(3)(4)</sup>	T <sub>2z</sub>	Nm	28	85	115	3	1
				38	115	155	4	
				40	110	195	5	
				25	65	135	7	
				18	50	120	8	
				15	38	95	10	
				44	130	210	9	2
				44	120	260	12	
				44	110	230	15	
				44	120	260	16	
				44	120	260	20	
				40	110	230	25	
				44	120	260	32	
				40	110	230	40	
				18	50	120	64	
				15	38	95	100	
Maximales Drehmoment <sup>(3)(4)</sup>	Maximum torque <sup>(3)(4)</sup>	T <sub>2max</sub>	Nm	44	105	184	3	1
				60	140	245	4	
				64	175	310	5	
				40	104	215	7	
				28	80	192	8	
				24	60	152	10	
				70	205	335	9	2
				70	192	415	12	
				70	176	365	15	
				70	192	415	16	
				70	192	415	20	
				64	176	365	25	
				70	192	415	32	
				64	176	365	40	
				28	80	192	64	
				24	60	152	100	

PLHE

<sup>(1)</sup> Übersetzungen (i=n<sub>1</sub>/n<sub>2</sub>)

<sup>(2)</sup> Anzahl Getriebestufen

<sup>(3)</sup> Applikationsspezifische Auslegung mit NCP – [www.neugart.com](http://www.neugart.com)

<sup>(4)</sup> Bezogen auf Referenz Spannsystemdurchmesser

<sup>(1)</sup> Ratios (i=n<sub>1</sub>/n<sub>2</sub>)

<sup>(2)</sup> Number of stages

<sup>(3)</sup> Application specific configuration with NCP – [www.neugart.com](http://www.neugart.com)

<sup>(4)</sup> Based on reference clamping system diameter

PLHE

Abtriebsdrehmomente	Output torques			PLHE060	PLHE080	PLHE120	i <sup>(1)</sup>	p <sup>(2)</sup>
Dauerdrehmoment <sup>(3)</sup>	Continuous torque <sup>(3)</sup>	T <sub>2D</sub>	Nm	23	43	97	3	1
				25	95	131	4	
				25	93	165	5	
				19,5	55	114	7	
				15	42	102	8	
				12,5	32	80	10	
				30	88	178	9	2
				32	102	220	12	
				35	93	195	15	
				35	102	220	16	
				37	102	220	20	
				34	93	195	25	
				37	102	220	32	
				34	93	195	40	
				15	42	102	64	
				12,5	32	80	100	

Antriebsdrehzahlen	Input speeds			PLHE060	PLHE080	PLHE120	i <sup>(1)</sup>	p <sup>(2)</sup>
Dauerantriebsdrehzahl <sup>(3)(4)</sup>	Continuous input speed <sup>(3)(4)</sup>	n <sub>1D</sub>	min <sup>-1</sup>	2250	2550	1350	3	1
				3400	2300	1600	4	
				3950	2800	1800	5	
				4500	3800	2500	7	
				4500	4000	3150	8	
				4500	4000	3500	10	
				4500	3850	1750	9	2
				4500	4000	2000	12	
				4500	4000	2550	15	
				4500	4000	2300	16	
				4500	4000	2850	20	
				4500	4000	3500	25	
				4500	4000	3500	32	
				4500	4000	3500	40	
				4500	4000	3500	64	
				4500	4000	3500	100	
Max. mechanische Antriebsdrehzahl <sup>(3)</sup>	Max. mechanical input speed <sup>(3)</sup>	n <sub>1max</sub>	min <sup>-1</sup>	13000	7000	6500		

Abtriebsdrehmomente	Output torques			PLHE060	PLHE080	PLHE120	i <sup>(1)</sup>	p <sup>(2)</sup>
Not-Aus Drehmoment <sup>(4)(5)</sup>	Emergency stop torque <sup>(4)(5)</sup>	T <sub>2Stop</sub>	Nm	60	150	375	3	1
				80	200	500	4	
				80	220	500	5	
				80	178	340	7	
				80	190	380	8	
				75	200	480	10	
				88	260	500	9	2
				88	240	520	12	
				88	220	500	15	
				88	240	520	16	
				88	240	520	20	
				80	220	500	25	
				88	240	520	32	
				80	220	500	40	
				80	190	380	64	
				75	200	480	100	

<sup>(1)</sup> Übersetzungen (i=n<sub>1</sub>/n<sub>2</sub>)

<sup>(2)</sup> Anzahl Getriebestufen

<sup>(3)</sup> Applikationsspezifische Auslegung mit NCP – [www.neugart.com](http://www.neugart.com)

<sup>(4)</sup> Bezogen auf Referenz Spannsystemdurchmesser

<sup>(5)</sup> 1000-mal zulässig

<sup>(1)</sup> Ratios (i=n<sub>1</sub>/n<sub>2</sub>)

<sup>(2)</sup> Number of stages

<sup>(3)</sup> Application specific configuration with NCP – [www.neugart.com](http://www.neugart.com)

<sup>(4)</sup> Based on reference clamping system diameter

<sup>(5)</sup> Permitted 1000 times

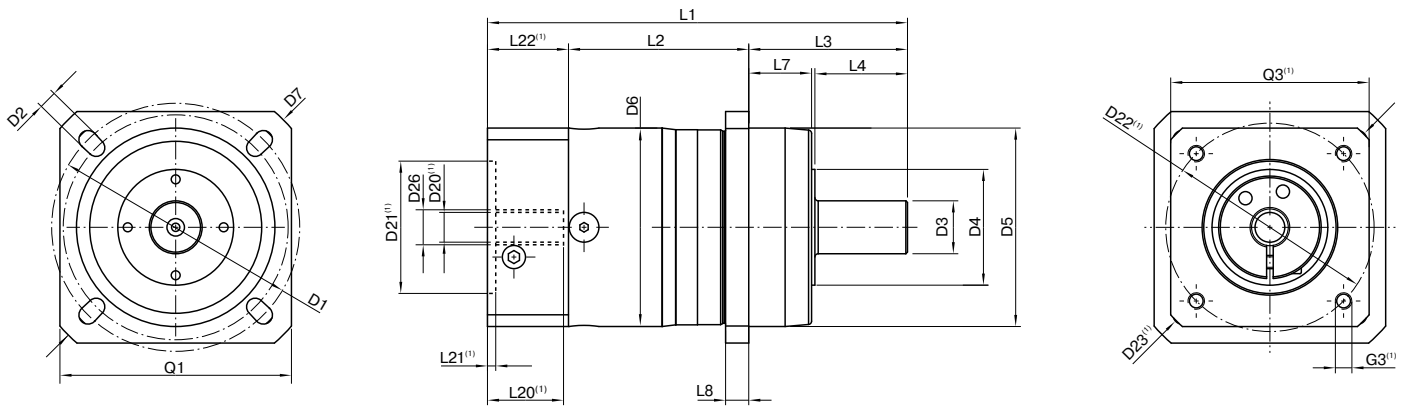

Darstellung entspricht einem PLHE060 / 1-stufig / glatte Abtriebswelle / 11 mm Spannsystem / Motoranpassung – einteilig / B5 Flanschtyp Motor  
 Drawing corresponds to a PLHE060 / 1-stage / smooth output shaft / 11 mm clamping system / motor adaptation – one part / B5 flange type motor

<sup>(1)</sup> Die Maße variieren je nach Motor-/Getriebeflansch. Die motorspezifischen Antriebsflansch-Geometrien können im Tec Data Finder für jeden Motor gezielt abgerufen werden - www.neugart.com  
<sup>(1)</sup> The dimensions vary with the motor/gearbox flange. The input flange dimensions can be retrieved for each specific motor in Tec Data Finder at www.neugart.com

Geometrie <sup>(2)</sup>	Geometry <sup>(2)</sup>			PLHE060	PLHE080	PLHE120	p <sup>(3)</sup>	Code
Lochkreisdurchmesser Abtrieb	Pitch circle diameter output	D1		68 - 75	85	120		
Montagebohrung Abtrieb	Mounting bore output	D2	4x	5,5	6,5	9,0		
Wellendurchmesser Abtrieb	Shaft diameter output	D3	k6	16	22	32		
Wellenansatz Abtrieb	Shaft collar output	D4		35	40	45		
Zentrierbunddurchmesser Abtrieb	Centering diameter output	D5	g7	60	70	90		
Gehäusedurchmesser	Housing diameter	D6		60	80	115		
Diagonalmass Abtrieb	Diagonal dimension output	D7		92	100	140		
Flanschquerschnitt Abtrieb	Flange cross section output	Q1	■	70	80	110		
Min. Gesamtlänge	Min. total length	L1		127	159	199,5	1	
				139,5	177	227	2	
Gehäuselänge	Housing length	L2		55	69,5	64	1	
				67,5	87	91,5	2	
Wellenlänge Abtrieb	Shaft length output	L3		48	56	88		
Zentrierbundtiefe Abtrieb	Centering depth output	L7		19	17,5	28		
Flanschdicke Abtrieb	Flange thickness output	L8		7	8	10		
Durchmesser Motorwelle j6/k6	Motor shaft diameter j6/k6	D20		Weitere Informationen auf Seite 191/192 More information on page 191/192				
Durchmesser Spannsystem am Antrieb	Clamping system diameter input	D26		Weitere Informationen auf Seite 42 More information on page 42				
Abtriebswelle mit Passfeder (DIN 6885-1)	Output shaft with feather key (DIN 6885-1)			A 5x5x25	A 6x6x28	A 10x8x50		A
Passfederbreite (DIN 6885-1)	Feather key width (DIN 6885-1)	B1		5	6	10		
Wellenhöhe inklusive Passfeder (DIN 6885-1)	Shaft height including feather key (DIN 6885-1)	H1		18	24,5	35		
Wellenlänge bis Bund	Shaft length from shoulder	L4		28	36	58		
Passfederlänge	Feather key length	L5		25	28	50		
Abstand vom Wellenende	Distance from shaft end	L6		2	4	4		
Zentrierbohrung (DIN 332, Form DR)	Center hole (DIN 332, type DR)	C		M5x12,5	M8x19	M12x28		
Glatte Abtriebswelle	Smooth output shaft							B
Wellenlänge bis Bund	Shaft length from shoulder	L4		28	36	58		
Verzähnte Abtriebswelle (DIN 5480)	Splined output shaft (DIN 5480)			W16x0,8x18x6m	W22x1,25x16x6m	W32x1,25x24x6m		C
Verzahnungsbreite	Width of gearing	L <sub>v</sub>		15	15	15		
Wellenlänge Abtrieb	Shaft length output	L3		46	46	56		
Wellenlänge bis Bund	Shaft length from shoulder	L4		26	26	26		
Zentrierbohrung (DIN 332, Form DR)	Center hole (DIN 332, type DR)	C		M5x12,5	M8x19	M12x28		

<sup>(2)</sup> Maße in mm  
<sup>(3)</sup> Anzahl Getriebestufen

<sup>(2)</sup> Dimensions in mm  
<sup>(3)</sup> Number of stages