



PLE

Unerreicht: Dieses Planetengetriebe ist maximal effizient auch bei höchsten Drehzahlen

Das **PLE** ist unser Preis-Leistungs-Wunder. Es ist besonders leicht, leistungsstark und dank seines reibungsarmen Lagerkonzepts und der optimierten Schmierung dennoch für anspruchsvolle Produktionszyklen geeignet. Ein echtes Kraftpaket zu einem attraktiven und fairen Preis.

Unparalleled: This planetary gearbox maintains its maximum efficiency even at the highest speeds

The **PLE** is our price/performance wonder. It is particularly lightweight, extremely powerful and yet still suitable for demanding production cycles thanks to its low-friction bearing concept and optimized lubrication. A real powerhouse at an attractive and fair price.

Zyklusdrehmoment Cyclic torque	5 - 800 Nm
Radialkraft Radial force	200 - 5000 N
Axialkraft Axial force	240 - 11000 N
Verdrehspiel Torsional backlash	6 - 22 arcmin
Schutzart Protection class	IP54

Baugrößen
Frame sizes

40	60	80	120	160
----	----	----	-----	-----

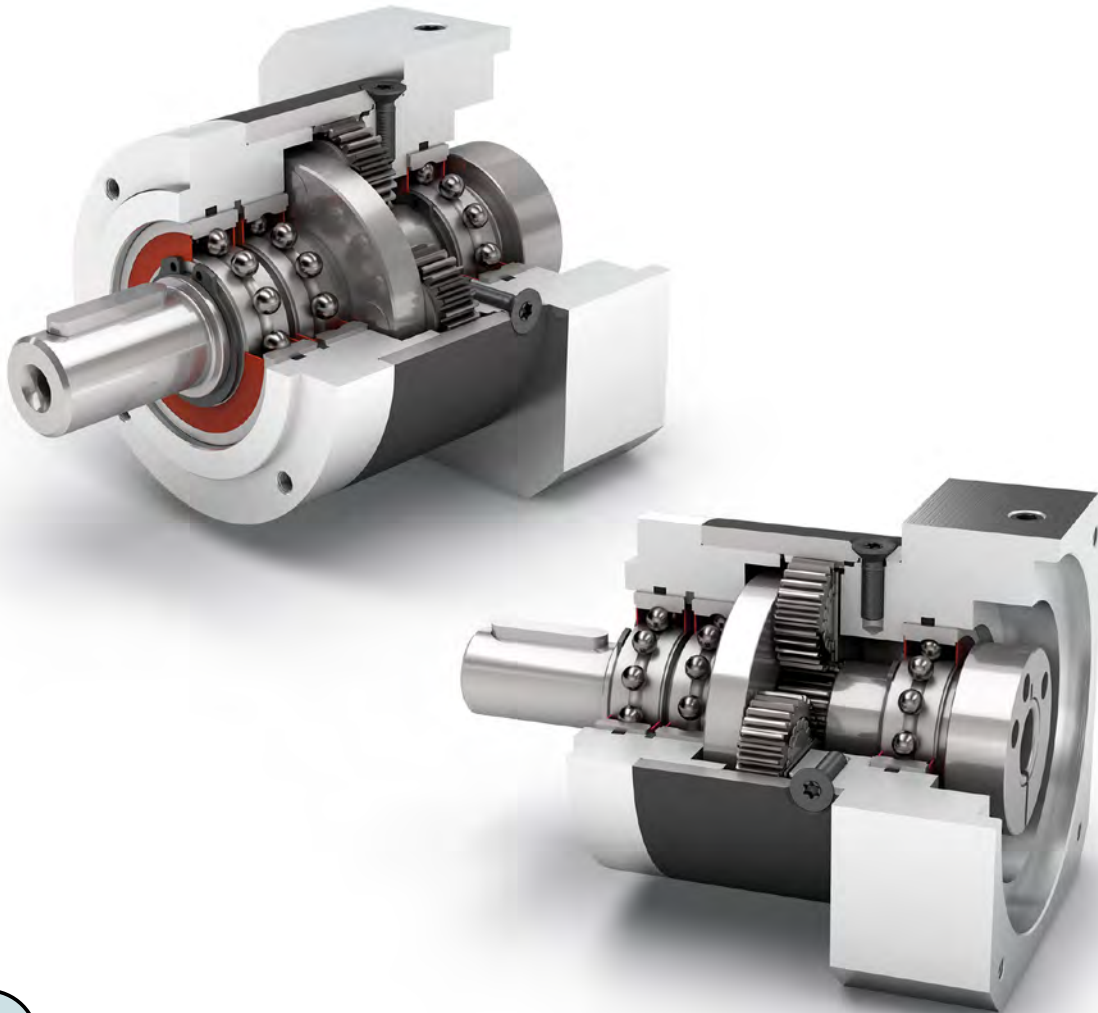

Economy Line
Economy Line

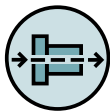

Koaxialgetriebe
Coaxial gearbox



Geradverzahnt
Spur gear



Reibungsarme Rillenkugellager
Low-friction deep groove ball bearings



Planetenträger in Scheibenausführung
Planet carrier in disc design

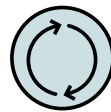

Drehrichtung gleichsinnig
Equidirectional rotation

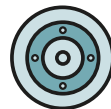

Runder Abtriebsflansch
Round type output flange



Hohe Übersetzungsvielfalt $i=3$ bis $i=512$
High ratio variety $i=3$ up to $i=512$



Option: Lackierte Oberfläche
– RAL 9005 Tiefschwarz
Option: Painted surface
– RAL 9005 Jet black

Detaillierte Erläuterungen der technischen Features ab Seite 201.
Detailed explanations of the technical features starting on page 201.

Code	Getriebekennwerte	Gearbox characteristics			PLE040	PLE060	PLE080	PLE120	PLE160	p ⁽¹⁾
	Lebensdauer ⁽²⁾	Service life ⁽²⁾	L _n	h	20.000					
	Wirkungsgrad ⁽³⁾	Efficiency ⁽³⁾	η	%	98					1
97					2					
92					3					
	Betriebstemperatur min.	Min. operating temperature	T _{min}	°C	-25					
	Betriebstemperatur max.	Max. operating temperature	T _{max}		90					
	Schutzart	Protection class			IP54					
S	Standard Schmierung	Standard lubrication			Fett (lebensdauergeschmiert) / Grease (lifetime lubrication)					
F	Lebensmitteltaugliche Schmierung	Food grade lubrication			Fett (lebensdauergeschmiert) / Grease (lifetime lubrication)					
	Einbaulage	Installation position			Beliebig / Any					
S	Standard Verdrehspiel	Standard backlash	φ	arcmin	< 15	< 10	< 7	< 7	< 6	1
					< 19	< 12	< 9	< 9	< 9	2
					< 22	< 15	< 11	< 11	-	3
	Verdrehsteifigkeit ⁽³⁾	Torsional stiffness ⁽³⁾	C _{2t}	Nm / arcmin	0,7 - 1,0	2,0 - 2,7	7,2 - 10,0	15,5 - 21,0	57,5 - 69,0	1
					0,8 - 1,0	2,3 - 2,8	7,9 - 10,4	17,5 - 22,0	61,0 - 75,0	2
					0,8 - 1,0	2,3 - 2,8	7,9 - 10,5	17,5 - 22,0	-	3
	Getriebegewicht ⁽³⁾	Gearbox weight ⁽³⁾	m	kg	0,4	0,9	2,1 - 2,2	5,6 - 5,9	17,3 - 17,5	1
					0,4 - 0,5	1,0 - 1,1	2,6 - 2,7	7,3 - 7,7	23,2 - 23,5	2
					0,5	1,2 - 1,3	3,0 - 3,2	9,1 - 9,5	-	3
S	Standard Oberfläche	Standard surface			Gehäuse: Stahl – wärmebehandelt und nachoxidiert (schwarz) Housing: Steel – heat-treated and post-oxidized (black)					
B	Lackierte Oberfläche ⁽⁴⁾	Painted surface ⁽⁴⁾			RAL 9005 Tiefschwarz RAL 9005 Jet black					
	Laufgeräusch ⁽³⁾	Running noise ⁽³⁾	L _{pA}	dB(A)	58	58	60	65	70	

Abtriebswellenbelastungen	Output shaft loads			PLE040	PLE060	PLE080	PLE120	PLE160	p ⁽¹⁾
Maximale Radialkraft	Maximum radial force	F _{r max}	N	200	700	1000	2000	5000	
Maximale Axialkraft	Maximum axial force	F _{a max}		240	800	1450	3800	11000	
Maximales Kippmoment	Maximum tilting moment	M _{K max}	Nm	6	25	41	115	474	

Antriebskennwerte	Input characteristics			PLE040	PLE060	PLE080	PLE120	PLE160	p ⁽¹⁾
Durchmesser Spannsystem am Antrieb (Code)	Clamping system diameter input (Code)	D26	mm	8 (A)	11 (C)	19 (E) ⁽⁵⁾	24 (F) ⁽⁵⁾	35 (G) ⁽⁵⁾	
				9 (B) ⁽⁵⁾	14 (D) ⁽⁵⁾	24 (F)	35 (G)	-	
				11 (C)	19 (E)	-	-	-	
Massenträgheitsmoment Antrieb ⁽³⁾⁽⁵⁾	Mass moment of inertia input ⁽³⁾⁽⁵⁾	J ₁	kgcm ²	0,022	0,085	0,359	1,378	3,726	1
				0,033	0,149	0,654	2,361	11,999	2
				0,022	0,086	0,365	1,414	3,502	
Mittleres Leerlaufdrehmoment ⁽³⁾⁽⁵⁾	Average idle torque ⁽³⁾⁽⁵⁾	T ₀	Nm	0,032	0,142	0,613	2,288	10,087	3
				0,022	0,086	0,365	1,413	-	
				0,031	0,096	0,590	2,196	-	
Max. Biegemoment bezogen auf den Getriebeantriebsflansch	Max. bending moment based on the gearbox input flange	M _{b1}	Nm	0,05	0,10 - 0,15	0,20 - 0,35	0,50 - 1,05	1,10 - 2,90	1
				0,05	0,10	0,15 - 0,25	0,45 - 0,80	0,80 - 1,80	2
				0,05	0,10	0,15 - 0,20	0,45 - 0,75	-	3
				4,5	12	16	40	140	

⁽¹⁾ Anzahl Getriebestufen

⁽²⁾ Applikationsspezifische Auslegung mit NCP – www.neugart.com

⁽³⁾ Die übersetzungsabhängigen Werte sind im Tec Data Finder abrufbar – www.neugart.com

⁽⁴⁾ Weitere Informationen auf Seite 183

⁽⁵⁾ Referenz Spannsystemdurchmesser

⁽¹⁾ Number of stages

⁽²⁾ Application specific configuration with NCP – www.neugart.com

⁽³⁾ The ratio-dependent values can be retrieved in Tec Data Finder – www.neugart.com

⁽⁴⁾ More information on page 183

⁽⁵⁾ Reference clamping system diameter

Abtriebsdrehmomente	Output torques			PLE040	PLE060	PLE080	PLE120	PLE160	i ⁽¹⁾	p ⁽²⁾
Zyklusdrehmoment ⁽³⁾⁽⁴⁾	Cyclic torque ⁽³⁾⁽⁴⁾	T _{2z}	Nm	11	28	85	115	400	3	1
				15	38	115	155	450	4	
				14	40	110	195	450	5	
				8,5	25	65	135	-	7	
				6	18	50	120	450	8	
				5	15	38	95	-	10	
				16,5	44	130	210	-	9	
				20	44	120	260	800	12	
				18	44	110	230	700	15	
				20	44	120	260	800	16	
				20	44	120	260	800	20	
				18	40	110	230	700	25	
				20	44	120	260	800	32	
				18	40	110	230	700	40	
				7,5	18	50	120	450	64	
				20	44	120	260	-	60	
				20	44	120	260	-	80	
				20	44	120	260	-	100	
				18	44	110	230	-	120	
				20	44	120	260	-	160	
				18	40	110	230	-	200	
				20	44	120	260	-	256	
				18	40	110	230	-	320	
				7,5	18	50	120	-	512	
Maximales Drehmoment ⁽³⁾⁽⁴⁾	Maximum torque ⁽³⁾⁽⁴⁾	T _{2max}	Nm	11	44	105	184	450	3	1
				24	60	140	245	600	4	
				22	64	175	310	720	5	
				13,5	40	104	215	-	7	
				9,5	28	80	192	720	8	
				8	24	60	152	-	10	
				16,5	70	205	335	-	9	
				32	70	192	415	1280	12	
				28	70	176	365	1120	15	
				32	70	192	415	1280	16	
				32	70	192	415	1280	20	
				28	64	176	365	1120	25	
				32	70	192	415	1280	32	
				28	64	176	365	1120	40	
				12	28	80	192	720	64	
				32	70	192	415	-	60	
				32	70	192	415	-	80	
				32	70	192	415	-	100	
				28	70	176	365	-	120	
				32	70	192	415	-	160	
				28	64	176	365	-	200	
				32	70	192	415	-	256	
				28	64	176	365	-	320	
				12	28	80	192	-	512	

⁽¹⁾ Übersetzungen (i=n₁/n₂)

⁽²⁾ Anzahl Getriebestufen

⁽³⁾ Applikationsspezifische Auslegung mit NCP – www.neugart.com

⁽⁴⁾ Bezogen auf Referenz Spannsystemdurchmesser

⁽¹⁾ Ratios (i=n₁/n₂)

⁽²⁾ Number of stages

⁽³⁾ Application specific configuration with NCP – www.neugart.com

⁽⁴⁾ Based on reference clamping system diameter

Abtriebsdrehmomente	Output torques			PLE040	PLE060	PLE080	PLE120	PLE160	i ⁽¹⁾	p ⁽²⁾
Dauerdrehmoment ⁽³⁾	Continuous torque ⁽³⁾	T _{2D}	Nm	3,5	22	37	97	340	3	1
				12,5	23	82	131	380	4	
				11,5	24	84	165	380	5	
				7	19,5	55	114	-	7	
				5	15	42	102	380	8	
				4	12,5	32	80	-	10	
				10,5	30	87	178	-	9	2
				14,5	32	102	220	680	12	
				15	35	93	195	590	15	
				17	35	102	220	680	16	
				17	37	102	220	680	20	
				15	34	93	195	590	25	
				17	37	102	220	680	32	3
				15	34	93	195	590	40	
				6	15	42	102	380	64	
				17	37	102	220	-	60	
				17	37	102	220	-	80	
				17	37	102	220	-	100	
				15	37	93	195	-	120	3
				17	37	102	220	-	160	
15	34	93	195	-	200					
17	37	102	220	-	256					
15	34	93	195	-	320					
6	15	42	102	-	512					

Antriebsdrehzahlen	Input speeds			PLE040	PLE060	PLE080	PLE120	PLE160	i ⁽¹⁾	p ⁽²⁾
Dauerantriebsdrehzahl ⁽³⁾⁽⁴⁾	Continuous input speed ⁽³⁾⁽⁴⁾	n _{1D}	min ⁻¹	5000	4500	4000	2150	1250	3	1
				5000	4500	3750	2300	1400	4	
				5000	4500	4000	2500	1700	5	
				5000	4500	4000	3500	-	7	
				5000	4500	4000	3500	2200	8	
				5000	4500	4000	3500	-	10	
				5000	4500	4000	2650	-	9	2
				5000	4500	4000	2750	1850	12	
				5000	4500	4000	3000	2000	15	
				5000	4500	4000	2850	1950	16	
				5000	4500	4000	3350	2300	20	
				5000	4500	4000	3500	2500	25	
				5000	4500	4000	3500	2900	32	3
				5000	4500	4000	3500	3000	40	
				5000	4500	4000	3500	3000	64	
				5000	4500	4000	3500	-	60	
				5000	4500	4000	3500	-	80	
				5000	4500	4000	3500	-	100	
				5000	4500	4000	3500	-	120	3
				5000	4500	4000	3500	-	160	
5000	4500	4000	3500	-	200					
5000	4500	4000	3500	-	256					
5000	4500	4000	3500	-	320					
5000	4500	4000	3500	-	512					
Max. mechanische Antriebsdrehzahl ⁽³⁾	Max. mechanical input speed ⁽³⁾	n _{1max}	min ⁻¹	18000	13000	7000	6500	6500		

⁽¹⁾ Übersetzungen (i=n₁/n₂)

⁽²⁾ Anzahl Getriebestufen

⁽³⁾ Applikationsspezifische Auslegung mit NCP – www.neugart.com

⁽⁴⁾ Bezogen auf Referenz Spannsystemdurchmesser

⁽¹⁾ Ratios (i=n₁/n₂)

⁽²⁾ Number of stages

⁽³⁾ Application specific configuration with NCP – www.neugart.com

⁽⁴⁾ Based on reference clamping system diameter

Abtriebsdrehmomente	Output torques			PLE040	PLE060	PLE080	PLE120	PLE160	i ⁽¹⁾	p ⁽²⁾
Not-Aus Drehmoment ⁽³⁾⁽⁴⁾	Emergency stop torque ⁽³⁾⁽⁴⁾	T _{2stop}	Nm	22	60	150	375	800	3	1
				30	80	200	500	900	4	
				36	80	220	500	900	5	
				26	80	178	340	-	7	
				27	80	190	380	900	8	
				27	75	200	480	-	10	
				33	88	260	500	-	9	2
				40	88	240	520	1600	12	
				36	88	220	500	1400	15	
				40	88	240	520	1600	16	
				40	88	240	520	1600	20	
				36	80	220	500	1400	25	
				40	88	240	520	1600	32	
				36	80	220	500	1400	40	
				27	80	190	380	900	64	
				40	88	220	520	-	60	
				40	88	240	520	-	80	
				40	88	240	520	-	100	
				36	88	220	500	-	120	
				40	88	240	520	-	160	
				36	80	220	500	-	200	
				40	88	240	520	-	256	
				36	80	220	500	-	320	
				27	80	190	380	-	512	

⁽¹⁾ Übersetzungen (i=n₁/n₂)

⁽²⁾ Anzahl Getriebestufen

⁽³⁾ 1000-mal zulässig

⁽⁴⁾ Bezogen auf Referenz Spannsystemdurchmesser

⁽¹⁾ Ratios (i=n₁/n₂)

⁽²⁾ Number of stages

⁽³⁾ Permitted 1000 times

⁽⁴⁾ Based on reference clamping system diameter

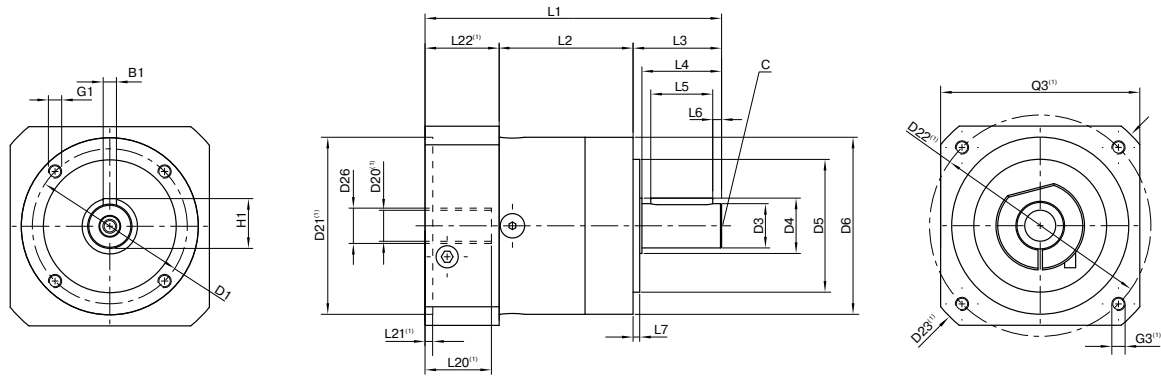

Darstellung entspricht einem PLE060 / 1-stufig / Abtriebswelle mit Passfeder / 11 mm Spannsystem / Motoranpassung – einteilig / B5 Flanschtyp Motor
 Drawing corresponds to a PLE060 / 1-stage / output shaft with feather key / 11 mm clamping system / motor adaptation – one part / B5 flange type motor

⁽¹⁾ Die Maße variieren je nach Motor-/Getriebeflansch. Die motorspezifischen Antriebsflansch-Geometrien können im Tec Data Finder für jeden Motor gezielt abgerufen werden - www.neugart.com
⁽¹⁾ The dimensions vary with the motor/gearbox flange. The input flange dimensions can be retrieved for each specific motor in Tec Data Finder at www.neugart.com

Geometrie ⁽²⁾	Geometry ⁽²⁾			PLE040	PLE060	PLE080	PLE120	PLE160	p ⁽³⁾	Code
Lochkreisdurchmesser Abtrieb	Pitch circle diameter output	D1		34	52	70	100	145		
Wellendurchmesser Abtrieb	Shaft diameter output	D3	h7	10	14	20	25	40		
Wellenansatz Abtrieb	Shaft collar output	D4		12	17	25	35	55		
Zentrierbunddurchmesser Abtrieb	Centering diameter output	D5	h7	26	40	60	80	130		
Gehäusedurchmesser	Housing diameter	D6		40	60	80	115	160		
Anschraubgewinde x Tiefe	Mounting thread x depth	G1	4x	M4x6	M5x8	M6x10	M10x16	M12x20		
Min. Gesamtlänge	Min. total length	L1		88,5	106	133,5	176,5	255,5	1	
				106,5	118,5	150,5	204	305	2	
				114	131	168,5	231,5	-	3	
Gehäuselänge	Housing length	L2		39	47	60	74	104	1	
				51,5	59,5	78	102	153,5	2	
				64,5	72	95	129,5	-	3	
Wellenlänge Abtrieb	Shaft length output	L3		26	35	40	55	87		
Zentrierbundtiefe Abtrieb	Centering depth output	L7		2	3	3	4	5		
Durchmesser Motorwelle j6/k6	Motor shaft diameter j6/k6	D20		Weitere Informationen auf Seite 191/192 More information on page 191/192						
Durchmesser Spannsystem am Antrieb	Clamping system diameter input	D26		Weitere Informationen auf Seite 20 More information on page 20						
Abtriebswelle mit Passfeder (DIN 6885-1)	Output shaft with feather key (DIN 6885-1)			A 3x3x18	A 5x5x25	A 6x6x28	A 8x7x40	A 12x8x65		A
Passfederbreite (DIN 6885-1)	Feather key width (DIN 6885-1)	B1		3	5	6	8	12		
Wellenhöhe inklusive Passfeder (DIN 6885-1)	Shaft height including feather key (DIN 6885-1)	H1		11,2	16	22,5	28	43		
Wellenlänge bis Bund	Shaft length from shoulder	L4		23	30	36	50	80		
Passfederlänge	Feather key length	L5		18	25	28	40	65		
Abstand vom Wellenende	Distance from shaft end	L6		2,5	2,5	4	5	8		
Zentrierbohrung (DIN 332, Form DR)	Center hole (DIN 332, type DR)	C		M3x9	M5x12,5	M6x16	M10x22	M16x36		
Glatte Abtriebswelle	Smooth output shaft									B
Wellenlänge bis Bund	Shaft length from shoulder	L4		23	30	36	50	80		

⁽²⁾ Maße in mm
⁽³⁾ Anzahl Getriebestufen

⁽²⁾ Dimensions in mm
⁽³⁾ Number of stages

