



PSBN

Das Hochleistungs-Präzisionsgetriebe mit Schrägverzahnung für einen besonders leisen Antrieb

Unser **PSBN** ist die ideale Kombination aus Präzisions-Planetengetriebe und effizienter Lagertechnologie. Es wurde speziell entwickelt, um bei hoher Drehzahl die maximale Performance zu erreichen. Durch die Schrägverzahnung arbeitet es besonders homogen – und ist überdurchschnittlich leise.

The high-performance precision planetary gearbox with helical gearing for a particularly quiet drive

Our **PSBN** is the ideal combination of a precision planetary gearbox and efficient bearing technology. It was designed specifically to achieve maximum performance at high speed. Thanks to the helical gearing, it operates particularly smoothly - and is quieter than average.

Zyklusdrehmoment Cyclic torque	11 - 470 Nm
Radialkraft Radial force	830 - 9500 N
Axialkraft Axial force	800 - 9600 N
Verdrehspiel Torsional backlash	1 - 8 arcmin
Schutzart Protection class	IP65

Baugrößen
Frame sizes

55	70	90	115	142
-----------	-----------	-----------	------------	------------

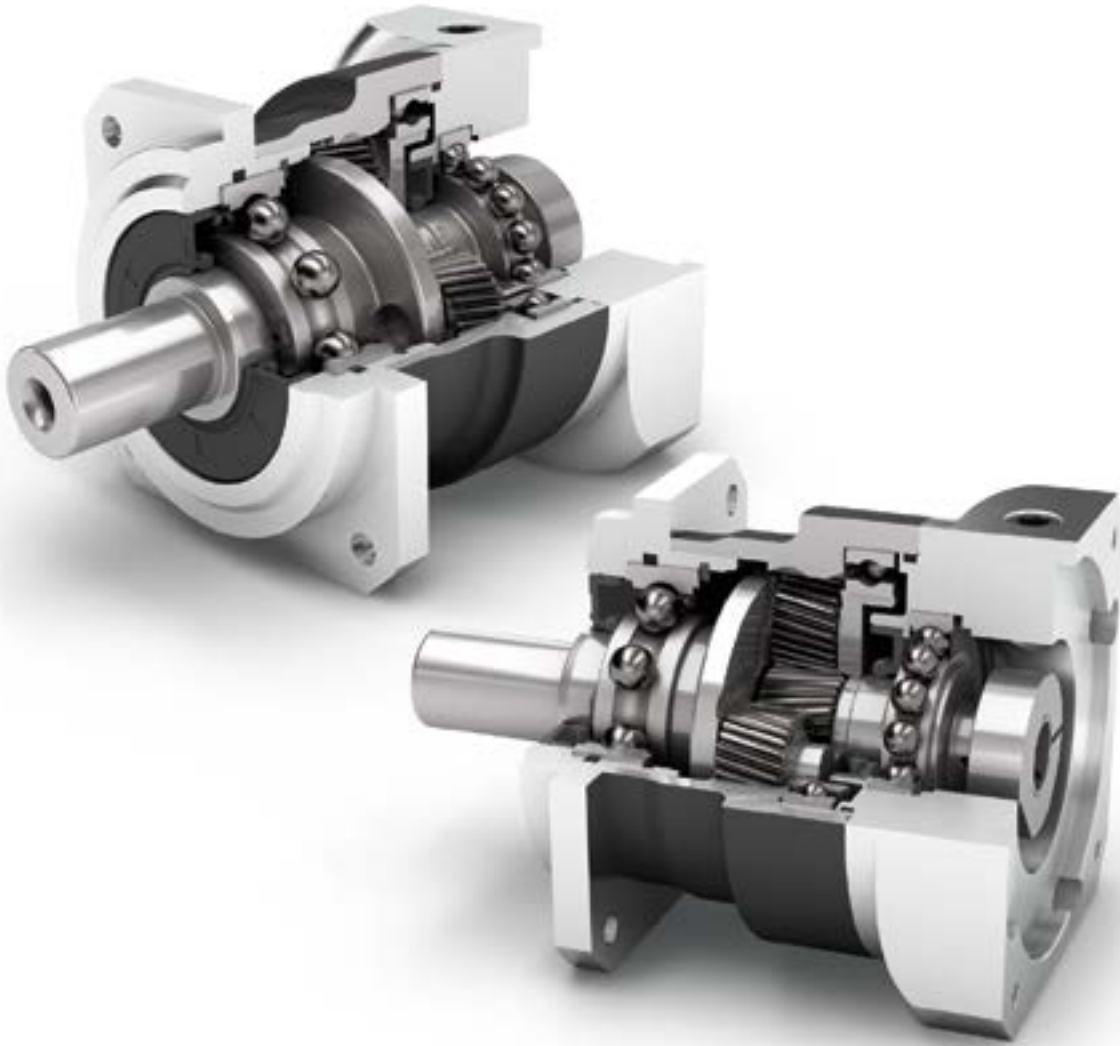

Precision Line
Precision Line



Drehrichtung gleichsinnig
Equidirectional rotation



Quadratischer Abtriebsflansch
Square type output flange



Radialwellendichtring
Rotary shaft seal



Option: Reduziertes Verdrehspiel
Option: Reduced backlash



Koaxialgetriebe
Coaxial gearbox



Schrägverzahnt
Helical gear



Verstärkte Rillenkugellager
Reinforced deep groove ball bearings



Planetenträger in Käfigausführung
Planet carrier in cage design



Option: Lackierte Oberfläche
– RAL 9005 Tiefschwarz
Option: Painted surface
– RAL 9005 Jet black

Detaillierte Erläuterungen der technischen Features ab Seite 201.
Detailed explanations of the technical features starting on page 201.

Code	Getriebekennwerte	Gearbox characteristics			PSBN055	PSBN070	PSBN090	PSBN115	PSBN142	p ⁽¹⁾	
	Lebensdauer ⁽²⁾	Service life ⁽²⁾	L _n	h	20.000						
	Wirkungsgrad ⁽³⁾	Efficiency ⁽³⁾	η	%	98					1	
					96					2	
	Betriebstemperatur min.	Min. operating temperature	T _{min}	°C	-25						
	Betriebstemperatur max.	Max. operating temperature	T _{max}		90						
	Schutzart	Protection class			IP65						
S	Standard Schmierung	Standard lubrication			Öl (lebensdauer geschmiert) / Oil (lifetime lubrication)						
F	Lebensmitteltaugliche Schmierung	Food grade lubrication			Öl (lebensdauer geschmiert) / Oil (lifetime lubrication)						
	Einbaulage	Installation position			Beliebig / Any						
S	Standard Verdrehspiel	Standard backlash	φ	arcmin	< 6	< 3	< 3	< 3	< 3	1	
					< 8	< 5	< 5	< 5	< 5	< 5	2
R	Reduziertes Verdrehspiel	Reduced backlash			< 4	< 2	< 1	< 1	< 1	< 1	1
					< 6	< 2	< 1	< 1	< 1	< 1	2
	Verdrehsteifigkeit ⁽³⁾	Torsional stiffness ⁽³⁾	C _{2t}	Nm / arcmin	1,4 - 2,3	4,2 - 5,6	10,7 - 13,7	29,0 - 36,5	59,5 - 76,0	1	
					1,5 - 2,4	4,1 - 5,7	10,3 - 13,5	26,0 - 35,0	58,0 - 71,0	2	
	Getriebege wicht ⁽³⁾	Gearbox weight ⁽³⁾	m	kg	0,8	1,6 - 1,7	3,3 - 3,4	5,6 - 6,0	13,2 - 13,5	1	
					1,1	2,3	3,5 - 3,6	7,1 - 7,3	15,0 - 15,5	2	
S	Standard Oberfläche	Standard surface			Gehäuse: Stahl – wärmebehandelt und nachoxidiert (schwarz) Housing: Steel – heat-treated and post-oxidized (black)						
B	Lackierte Oberfläche ⁽⁴⁾	Painted surface ⁽⁴⁾			RAL 9005 Tiefschwarz RAL 9005 Jet black						
	Laufgeräusch ⁽³⁾	Running noise ⁽³⁾	L _{PA}	dB(A)	56	57	58	63	66		

Abtriebswellenbelastungen	Output shaft loads			PSBN055	PSBN070	PSBN090	PSBN115	PSBN142	p ⁽¹⁾
Maximale Radialkraft	Maximum radial force	F _{r max}	N	830	1600	3100	4500	9500	
Maximale Axialkraft	Maximum axial force	F _{a max}		800	1500	2800	4500	9600	
Maximales Kippmoment	Maximum tilting moment	M _{K max}	Nm	42	109	251	442	1314 - 1329	

Antriebskennwerte	Input characteristics			PSBN055	PSBN070	PSBN090	PSBN115	PSBN142	p ⁽¹⁾
Durchmesser Spannsystem am Antrieb (Code)	Clamping system diameter input (Code)	D26	mm	11 (C) ⁽⁵⁾	11 (C)	14 (D)	19 (E)	35 (G) ⁽⁵⁾	1
				14 (D)	14 (D) ⁽⁵⁾	19 (E) ⁽⁵⁾	24 (F) ⁽⁵⁾	42 (H)	
				-	19 (E)	24 (F)	35 (G)	-	
				11 (C) ⁽⁵⁾	11 (C)	11 (C)	14 (D)	19 (E)	2
				14 (D)	14 (D) ⁽⁵⁾	14 (D) ⁽⁵⁾	19 (E) ⁽⁵⁾	24 (F) ⁽⁵⁾	
-	19 (E)	19 (E)	24 (F)	35 (G)					
Massenträgheitsmoment Antrieb ⁽³⁾⁽⁵⁾	Mass moment of inertia input ⁽³⁾⁽⁵⁾	J _i	kgcm ²	0,096	0,148	0,434	1,153	6,505	1
				0,129	0,273	0,870	2,811	14,061	
				0,095	0,146	0,147	0,435	1,143	2
				0,111	0,203	0,228	0,736	2,366	
Mittleres Leerlaufdrehmoment ⁽³⁾⁽⁵⁾	Average idle torque ⁽³⁾⁽⁵⁾	T ₀	Nm	0,15 - 0,25	0,20 - 0,60	0,40 - 1,20	0,70 - 2,40	1,30 - 6,60	1
				0,15 - 0,25	0,20 - 0,40	0,25 - 0,60	0,45 - 1,20	0,65 - 2,70	2
Maximales Biegemoment am Antrieb	Maximum bending moment input	M _{b1}	Nm	10	18	38	80	180	1
				10	18	18	38	80	2

⁽¹⁾ Anzahl Getriebestufen

⁽²⁾ Applikationsspezifische Auslegung mit NCP – www.neugart.com

⁽³⁾ Die übersetzungsabhängigen Werte sind im Tec Data Finder abrufbar – www.neugart.com

⁽⁴⁾ Weitere Informationen auf Seite 183

⁽⁵⁾ Referenz Spannsystemdurchmesser

⁽¹⁾ Number of stages

⁽²⁾ Application specific configuration with NCP – www.neugart.com

⁽³⁾ The ratio-dependent values can be retrieved in Tec Data Finder – www.neugart.com

⁽⁴⁾ More information on page 183

⁽⁵⁾ Reference clamping system diameter

Abtriebsdrehmomente	Output torques			PSBN055	PSBN070	PSBN090	PSBN115	PSBN142	i ⁽¹⁾	p ⁽²⁾
Zyklusdrehmoment ⁽³⁾⁽⁴⁾	Cyclic torque ⁽³⁾⁽⁴⁾	T _{2z}	Nm	16	29	54	135	380	3	1
				18	39	80	180	470	4	
				18	40	80	175	405	5	
				18	37	78	170	355	7	
				18	39	75	155	350	8	
				13,5	28	59	140	270	10	
				16	29	54	135	380	12	2
				16	29	54	135	380	15	
				18	39	80	180	470	16	
				18	39	80	180	470	20	
				18	40	80	175	405	25	
				18	40	80	175	405	35	
				18	39	80	180	470	40	
				18	40	80	175	405	50	
18	37	78	170	355	70					
13,5	28	59	140	270	100					
Maximales Drehmoment ⁽³⁾⁽⁴⁾	Maximum torque ⁽³⁾⁽⁴⁾	T _{2max}	Nm	25	46	86	215	520	3	1
				28	62	128	285	700	4	
				28	64	128	280	640	5	
				28	59	124	270	560	7	
				28	62	120	245	490	8	
				21	44	94	220	435	10	
				25	46	86	215	600	12	2
				25	46	86	215	600	15	
				28	62	128	285	750	16	
				28	62	128	285	750	20	
				28	64	128	280	640	25	
				28	64	128	280	640	35	
				28	62	128	285	750	40	
				28	64	128	280	640	50	
28	51	124	270	560	70					
21	44	94	220	435	100					

⁽¹⁾ Übersetzungen (i=n₁/n₂)

⁽²⁾ Anzahl Getriebestufen

⁽³⁾ Applikationsspezifische Auslegung mit NCP – www.neugart.com

⁽⁴⁾ Bezogen auf Referenz Spannsystemdurchmesser

⁽¹⁾ Ratios (i=n₁/n₂)

⁽²⁾ Number of stages

⁽³⁾ Application specific configuration with NCP – www.neugart.com

⁽⁴⁾ Based on reference clamping system diameter

Abtriebsdrehmomente	Output torques			PSBN 055	PSBN 070	PSBN 090	PSBN 115	PSBN 142	i ⁽¹⁾	p ⁽²⁾		
Dauerdrehmoment ⁽³⁾	Continuous torque ⁽³⁾	T _{2D}	Nm	11	24	45	114	320	3	1		
				15	33	68	153	395	4			
				15	34	68	148	340	5			
				15	31	66	148	300	7			
				15	33	63	131	295	8			
				11	23	50	119	255	10			
				13,5	24	45	114	320	12			
				13,5	24	45	114	320	15			
						15	33	68	153	395	16	2
						15	33	68	153	395	20	
						15	34	68	148	340	25	
						15	34	68	148	340	35	
						15	33	68	153	395	40	
						15	34	68	148	340	50	
						15	31	66	148	300	70	
						11	23	50	119	255	100	

Antriebsdrehzahlen	Input speeds			PSBN 055	PSBN 070	PSBN 090	PSBN 115	PSBN 142	i ⁽¹⁾	p ⁽²⁾		
Dauerantriebsdrehzahl ⁽³⁾⁽⁴⁾	Continuous input speed ⁽³⁾⁽⁴⁾	n _{1D}	min ⁻¹	4300	3650	3150	2100	1450	3	1		
				4300	4450	3050	2250	1650	4			
				4850	4500	3850	3050	2400	5			
				5000	4500	4000	3500	3000	7			
				5000	4500	4000	3500	3000	8			
				5000	4500	4000	3500	3000	10			
				4400	4500	4500	3650	2550	12			
				4900	4500	4500	4000	3200	15			
						4600	4500	4500	3600	2500	16	2
						5000	4500	4500	4000	3150	20	
						5000	4500	4500	4000	3500	25	
						5000	4500	4500	4000	3500	35	
						5000	4500	4500	4000	3500	40	
						5000	4500	4500	4000	3500	50	
Max. mechanische Antriebsdrehzahl ⁽³⁾	Max. mechanical input speed ⁽³⁾	n _{1max}	min ⁻¹	10000	10000	10000	8500	6500		1		
				10000	10000	10000	10000	8500		2		

Abtriebsdrehmomente	Output torques			PSBN 055	PSBN 070	PSBN 090	PSBN 115	PSBN 142	i ⁽¹⁾	p ⁽²⁾		
Not-Aus Drehmoment ⁽⁴⁾⁽⁵⁾	Emergency stop torque ⁽⁴⁾⁽⁵⁾	T _{2Stop}	Nm	48	90	210	490	1050	3	1		
				48	120	280	650	1400	4			
				48	130	280	650	1650	5			
				48	80	175	340	1300	7			
				48	90	200	380	850	8			
				24	52	121	295	600	10			
				48	135	220	500	1250	12			
				48	135	220	500	1250	15			
						48	150	300	650	1650	16	2
						48	150	300	650	1650	20	
						48	150	300	650	1650	25	
						48	89	300	650	1650	35	
						48	150	210	485	1180	40	
						48	150	260	600	1480	50	
						48	80	175	340	1300	70	
						24	52	121	295	600	100	

⁽¹⁾ Übersetzungen (i=n₁/n₂)

⁽²⁾ Anzahl Getriebestufen

⁽³⁾ Applikationsspezifische Auslegung mit NCP – www.neugart.com

⁽⁴⁾ Bezogen auf Referenz Spannsystemdurchmesser

⁽⁵⁾ 1000-mal zulässig

⁽¹⁾ Ratios (i=n₁/n₂)

⁽²⁾ Number of stages

⁽³⁾ Application specific configuration with NCP – www.neugart.com

⁽⁴⁾ Based on reference clamping system diameter

⁽⁵⁾ Permitted 1000 times

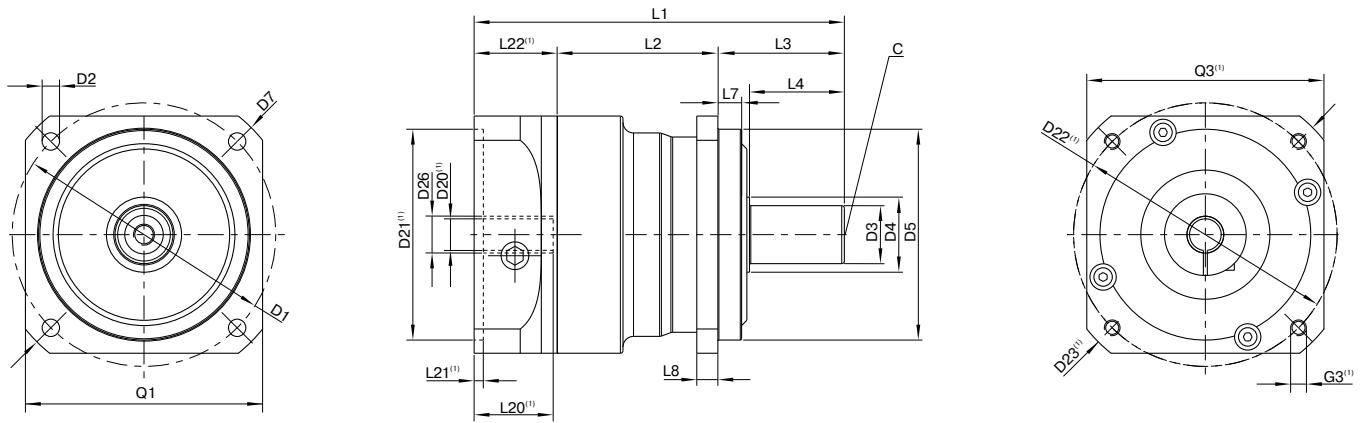

Darstellung entspricht einem PSBN090 / 1-stufig / glatte Abtriebswelle / 14 mm Spannsystem / Motoranpassung – 2-teilig – runder Universalfansch / B5 Flanschttyp Motor
 Drawing corresponds to a PSBN090 / 1-stage / smooth output shaft / 14 mm clamping system / motor adaptation – 2-part – round universal flange / B5 flange type motor

⁽¹⁾ Die Maße variieren je nach Motor-/Getriebeflansch. Die motorspezifischen Antriebsflansch-Geometrien können im Tec Data Finder für jeden Motor gezielt abgerufen werden - www.neugart.com
⁽¹⁾ The dimensions vary with the motor/gearbox flange. The input flange dimensions can be retrieved for each specific motor in Tec Data Finder at www.neugart.com

Geometrie ⁽²⁾	Geometry ⁽²⁾			PSBN055	PSBN070	PSBN090	PSBN115	PSBN142	p ⁽³⁾	Code
Lochkreisdurchmesser Abtrieb	Pitch circle diameter output	D1		63	70	100	130	165		
Montagebohrung Abtrieb	Mounting bore output	D2	4x	5,5	5,5	6,6	9,0	11,0		
Wellendurchmesser Abtrieb	Shaft diameter output	D3	j6	13	16	22	32	40		
Wellenansatz Abtrieb	Shaft collar output	D4		17	25	28,5	38,5	48,5		
Zentrierbunddurchmesser Abtrieb	Centering diameter output	D5	g6	50	50	80	110	130		
Diagonalmass Abtrieb	Diagonal dimension output	D7		74	80	115	148	185		
Flanschquerschnitt Abtrieb	Flange cross section output	Q1	■	55	60	90	115	140		
Min. Gesamtlänge	Min. total length	L1		93,5	116,5	140,5	182,5	247,5	1	
				117	145	162,5	204	279	2	
Gehäuselänge	Housing length	L2		43	54	61	74	100,5	1	
				66,5	82,5	89	107,5	138,5	2	
Wellenlänge Abtrieb	Shaft length output	L3		26	37	48	65	97		
Zentrierbundtiefe Abtrieb	Centering depth output	L7		6	6	9	4	12		
Flanschdicke Abtrieb	Flange thickness output	L8		6	6	8	10	12		
Zentrierbohrung (DIN 332, Form DR)	Center hole (DIN 332, type DR)	C		M4x10	M5x12,5	M8x19	M12x28	M16x36		
Durchmesser Motorwelle j6/k6	Motor shaft diameter j6/k6	D20		Weitere Informationen auf Seite 191/192 More information on page 191/192						
Durchmesser Spannsystem am Antrieb	Clamping system diameter input	D26		Weitere Informationen auf Seite 124 More information on page 124						
Abtriebswelle mit Passfeder (DIN 6885-1)	Output shaft with feather key (DIN 6885-1)			A 5x5x16	A 5x5x25	A 6x6x28	A 10x8x50	A 12x8x65		A
Passfederbreite (DIN 6885-1)	Feather key width (DIN 6885-1)	B1		5	5	6	10	12		
Wellenhöhe inklusive Passfeder (DIN 6885-1)	Shaft height including feather key (DIN 6885-1)	H1		15	18	24,5	35	43		
Wellenlänge bis Bund	Shaft length from shoulder	L4		19	28	36	58	82		
Passfederlänge	Feather key length	L5		16	25	28	50	65		
Abstand vom Wellenende	Distance from shaft end	L6		2	2	4	4	8		
Glatte Abtriebswelle	Smooth output shaft									
Wellenlänge bis Bund	Shaft length from shoulder	L4		19	28	36	58	82		

⁽²⁾ Maße in mm
⁽³⁾ Anzahl Getriebestufen

⁽²⁾ Dimensions in mm
⁽³⁾ Number of stages