



# PLN

The perfectly sealed planetary gearbox with straight gearing delivers the maximum performance without ever losing the required stiffness

Our precision straight-toothed planetary gearbox is designed for maximum power and torque. The preloaded tapered roller bearings in the **PLN** and the specially matched seal guarantee optimum performance even in applications where dust and water spray are encountered.

Cyclic torque **27 - 1800 Nm**



Radial force **3200 - 21000 N**



Axial force **4400 - 21000 N**



Torsional backlash **1 - 5 arcmin**



Protection class **IP65**



Frame sizes

- 70
- 90
- 115
- 142
- 190

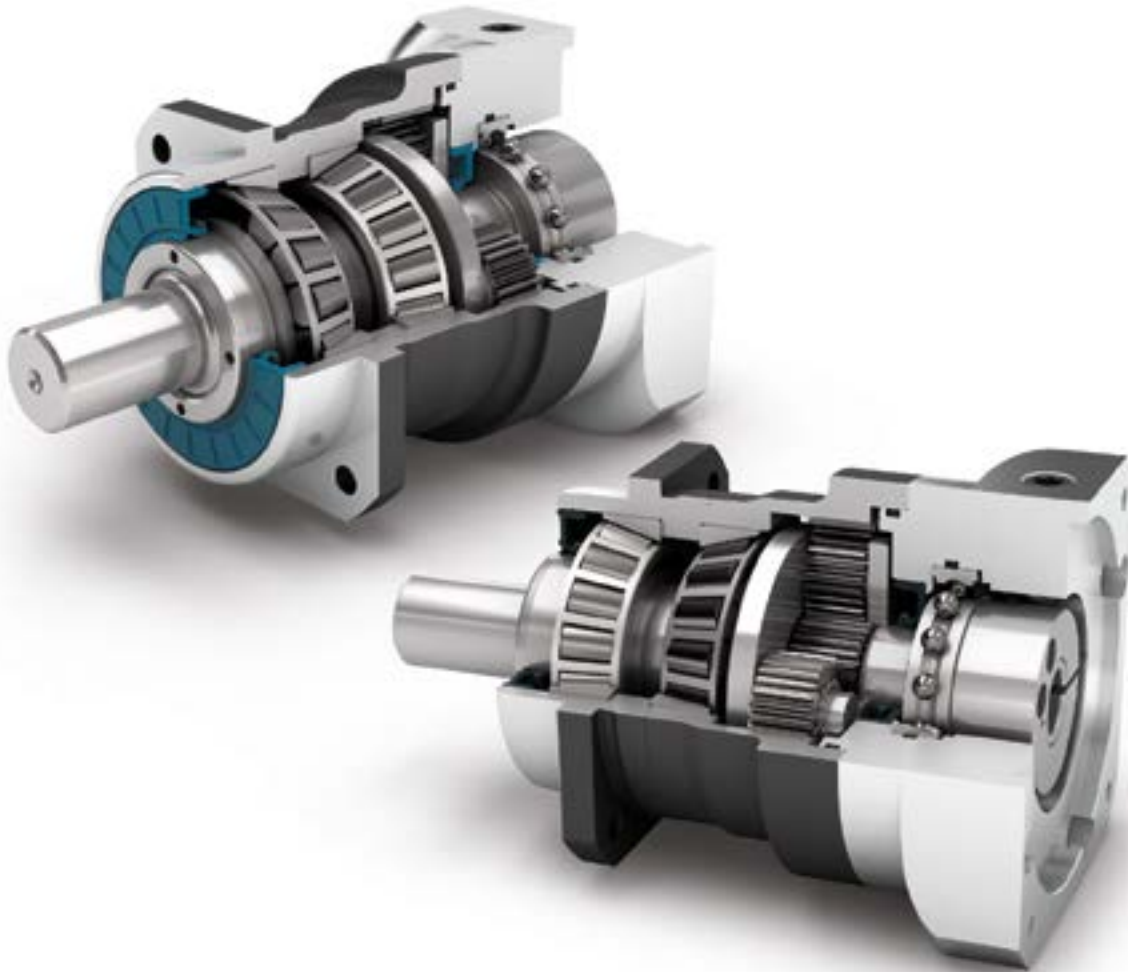

Precision Line



Spur gear



Preloaded tapered roller bearings



Extra long centering collar



Option: Reduced backlash



Option: Rack and pinion  
Planetary gearbox (Details on page 158)

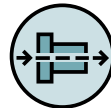

Coaxial gearbox

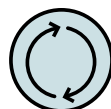

Equidirectional rotation

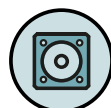

Square type output flange



Rotary shaft seal



Planet carrier in cage design



Option: Painted surface  
– RAL 9005 Jet black

Detailed explanations of the technical features starting on page 201.

Code	Gearbox characteristics			PLN070	PLN090	PLN115	PLN142	PLN190	p <sup>(1)</sup>
	Service life <sup>(2)</sup>	L <sub>h</sub>	h	20,000					
	Efficiency <sup>(3)</sup>	η	%	98					1
				95					2
	Min. operating temperature	T <sub>min</sub>	°C	-25 (-13)					
	Max. operating temperature	T <sub>max</sub>	(°F)	90 (194)					
	Protection class			IP65					
<b>S</b>	Standard lubrication			Oil (lifetime lubrication)					
<b>F</b>	Food grade lubrication			Oil (lifetime lubrication)					
	Installation position			Any					
<b>S</b>	Standard backlash	φ	arcmin	< 3					1
<b>R</b>				Reduced backlash	< 5				
	Torsional stiffness <sup>(3)</sup>	C <sub>2t</sub>	Nm / arcmin (lb <sub>i</sub> .in / arcmin)	3.4 - 5.0 (30 - 44)	9.4 - 12.4 (83 - 110)	22.0 - 29.0 (195 - 257)	61.0 - 76.0 (540 - 673)	155.0 - 218.0 (1372 - 1929)	1
				3.4 - 5.0 (30 - 44)	9.0 - 12.4 (80 - 110)	22.5 - 29.5 (199 - 261)	61.0 - 78.0 (540 - 690)	169.0 - 224.0 (1496 - 1983)	2
	Gearbox weight <sup>(3)</sup>	m	kg (lb <sub>m</sub> )	1.9 - 2.0 (4.3 - 4.4)	3.3 - 3.5 (7.3 - 7.6)	6.4 - 7.2 (14.1 - 15.9)	15.8 - 17.3 (34.8 - 38.2)	32.9 - 41.5 (72.6 - 91.5)	1
				2.4 - 2.5 (5.4 - 5.5)	4.0 - 4.2 (8.8 - 9.2)	8.0 - 8.8 (17.7 - 19.4)	20.8 - 21.5 (45.9 - 47.4)	44.3 - 48.5 (97.7 - 106.9)	2
<b>S</b>	Standard surface			Housing: Steel – heat-treated and post-oxidized (black)					
<b>B</b>	Painted surface <sup>(4)</sup>			RAL 9005 Jet black					
	Running noise <sup>(5)</sup>	L <sub>pA</sub>	dB(A)	60	62	65	70	74	

Output shaft loads			PLN070	PLN090	PLN115	PLN142	PLN190	p <sup>(1)</sup>
Maximum radial force	F <sub>r max</sub>	N (lb <sub>i</sub> )	3200 (719)	5500 (1236)	6000 (1349)	12500 (2810)	21000 (4721)	
Maximum axial force	F <sub>a max</sub>		3400 (764)	4500 (1012)	6500 (1461)	12000 (2698)	17000 (3822)	
Maximum tilting moment	M <sub>K max</sub>	Nm (lb <sub>i</sub> .in)	191 (1690)	383 (3393)	488 (4317)	1420 (12572)	2535 (22434)	

Input characteristics			PLN070	PLN090	PLN115	PLN142	PLN190	p <sup>(1)</sup>
Clamping system diameter input (Code)	D26	mm	14 (D) <sup>(5)</sup>	19 (E) <sup>(5)</sup>	24 (F) <sup>(5)</sup>	35 (G) <sup>(5)</sup>	48 (K) <sup>(5)</sup>	
			19 (E)	24 (F)	35 (G)	42 (H)	-	
Mass moment of inertia input <sup>(3)(5)</sup>	J <sub>i</sub>	kgcm <sup>2</sup> (lb <sub>i</sub> .in.s <sup>2</sup> 10 <sup>-4</sup> )	0.216 - 0.365 (1.912 - 3.231)	0.560 - 1.028 (4.956 - 9.099)	1.942 - 3.256 (17.188 - 28.818)	7.008 - 15.270 (62.026 - 135.151)	22.876 - 63.815 (202.470 - 564.810)	1
			0.209 - 0.249 (1.850 - 2.204)	0.544 - 0.699 (4.815 - 6.187)	1.933 - 2.373 (17.108 - 21.003)	6.811 - 9.813 (60.282 - 86.852)	22.430 - 36.003 (198.522 - 318.653)	2
Average idle torque <sup>(3)(5)</sup>	T <sub>0</sub>	Nm (lb <sub>i</sub> .in)	0.25 - 0.70 (2 - 6)	0.40 - 1.15 (4 - 10)	0.85 - 2.30 (8 - 20)	1.85 - 8.00 (16 - 71)	3.70 - 18.90 (33 - 167)	1
			0.20 - 0.35 (2 - 3)	0.30 - 0.70 (3 - 6)	0.65 - 1.75 (6 - 15)	1.40 - 5.70 (12 - 50)	2.90 - 13.90 (26 - 123)	2
Maximum bending moment input	M <sub>b1</sub>		18 (159)	38 (336)	80 (708)	180 (1593)	300 (2655)	

<sup>(1)</sup> Number of stages

<sup>(2)</sup> Application specific configuration with NCP – www.neugart.com

<sup>(3)</sup> The ratio-dependent values can be retrieved in Tec Data Finder – www.neugart.com

<sup>(4)</sup> More information on page 183

<sup>(5)</sup> Reference clamping system diameter

Output torques			PLN070	PLN090	PLN115	PLN142	PLN190	i <sup>(1)</sup>	p <sup>(2)</sup>
Cyclic torque <sup>(3)(4)</sup>	T <sub>z2</sub>	Nm (lb <sub>f</sub> .in)	45 (398)	105 (929)	230 (2036)	450 (3983)	990 (8762)	3	1
			60 (531)	140 (1239)	300 (2655)	600 (5310)	1330 (11771)	4	
			65 (575)	140 (1239)	260 (2301)	750 (6638)	1660 (14692)	5	
			39 (345)	86 (761)	170 (1505)	510 (4514)	1100 (9736)	7	
			40 (354)	80 (708)	150 (1328)	450 (3983)	1000 (8851)	8	
			27 (239)	60 (531)	125 (1106)	270 (2390)	630 (5576)	10	
			68 (602)	110 (974)	250 (2213)	780 (6904)	1500 (13276)	12	2
			68 (602)	110 (974)	250 (2213)	780 (6904)	1500 (13276)	15	
			77 (682)	150 (1328)	300 (2655)	1000 (8851)	1800 (15931)	16	
			77 (682)	150 (1328)	300 (2655)	1000 (8851)	1800 (15931)	20	
			65 (575)	140 (1239)	260 (2301)	900 (7966)	1800 (15931)	25	
			77 (682)	150 (1328)	300 (2655)	1000 (8851)	1800 (15931)	32	
			65 (575)	140 (1239)	260 (2301)	900 (7966)	1800 (15931)	40	
			40 (354)	80 (708)	150 (1328)	450 (3983)	1000 (8851)	64	
			27 (239)	60 (531)	125 (1106)	280 (2478)	600 (5310)	100	
			Maximum torque <sup>(3)(4)</sup>	T <sub>2max</sub>	Nm (lb <sub>f</sub> .in)	45 (398)	105 (929)	230 (2036)	
60 (531)	140 (1239)	305 (2699)				600 (5310)	1330 (11771)	4	
75 (664)	175 (1549)	385 (3408)				750 (6638)	1660 (14692)	5	
59 (522)	138 (1221)	260 (2301)				810 (7169)	1270 (11240)	7	
64 (566)	128 (1133)	240 (2124)				560 (4956)	1410 (12480)	8	
43 (381)	96 (850)	200 (1770)				325 (2876)	1000 (8851)	10	
105 (929)	176 (1558)	400 (3540)				1240 (10975)	2400 (21242)	12	2
105 (929)	176 (1558)	400 (3540)				1240 (10975)	2400 (21242)	15	
103 (912)	240 (2124)	480 (4248)				1600 (14161)	2880 (25490)	16	
103 (912)	240 (2124)	480 (4248)				1600 (14161)	2880 (25490)	20	
97 (859)	220 (1947)	415 (3673)				1440 (12745)	2880 (25490)	25	
103 (912)	240 (2124)	480 (4248)				1600 (14161)	2880 (25490)	32	
97 (859)	220 (1947)	415 (3673)				1440 (12745)	2880 (25490)	40	
62 (549)	128 (1133)	240 (2124)				560 (4956)	1410 (12480)	64	
43 (381)	96 (850)	200 (1770)				325 (2876)	840 (7435)	100	

<sup>(1)</sup> Ratios (i=n<sub>1</sub>/n<sub>2</sub>)  
<sup>(2)</sup> Number of stages  
<sup>(3)</sup> Application specific configuration with NCP – www.neugart.com  
<sup>(4)</sup> Based on reference clamping system diameter

Output torques			PLN070	PLN090	PLN115	PLN142	PLN190	i <sup>(1)</sup>	p <sup>(2)</sup>
Continuous torque <sup>(3)</sup>	T <sub>2D</sub>	Nm (lb <sub>r</sub> .in)	22 (195)	50 (443)	115 (1018)	225 (1991)	500 (4425)	3	1
			30 (266)	70 (620)	150 (1328)	300 (2655)	650 (5753)	4	
			32 (283)	70 (620)	130 (1151)	375 (3319)	800 (7081)	5	
			22 (195)	45 (398)	90 (797)	265 (2345)	650 (5753)	7	
			20 (177)	40 (354)	75 (664)	225 (1991)	500 (4425)	8	
			13.5 (119)	30 (266)	62 (549)	152 (1345)	315 (2788)	10	
		34 (301)	55 (487)	125 (1106)	390 (3452)	750 (6638)	12	2	
		34 (301)	55 (487)	125 (1106)	390 (3452)	750 (6638)	15		
		38 (336)	75 (664)	150 (1328)	500 (4425)	900 (7966)	16		
		38 (336)	75 (664)	150 (1328)	500 (4425)	900 (7966)	20		
		32 (283)	70 (620)	130 (1151)	450 (3983)	900 (7966)	25		
		38 (336)	75 (664)	150 (1328)	500 (4425)	900 (7966)	32		
		32 (283)	70 (620)	130 (1151)	450 (3983)	900 (7966)	40		
		20 (177)	40 (354)	75 (664)	225 (1991)	500 (4425)	64		
		13.5 (119)	30 (266)	62 (549)	152 (1345)	315 (2788)	100		

Input speeds			PLN070	PLN090	PLN115	PLN142	PLN190	i <sup>(1)</sup>	p <sup>(2)</sup>
Continuous input speed <sup>(3)(4)</sup>	n <sub>1D</sub>	rpm	2050	1950	1500	850	700	3	1
			2300	2100	1600	950	750	4	
			2650	2500	2000	1050	850	5	
			3450	3550	2800	1550	1200	7	
			3800	3950	3200	1800	1450	8	
			4400	4000	3500	2250	1900	10	
		3550	3400	2450	1300	1000	12	2	
		4000	4000	3000	1600	1250	15		
		3800	3550	2550	1350	1050	16		
		4300	4000	3050	1600	1300	20		
		4500	4000	3400	1850	1400	25		
		4500	4000	3500	2300	1900	32		
		4500	4000	3500	2550	2100	40		
		4500	4000	3500	3000	2500	64		
		4500	4000	3500	3000	2500	100		
		Max. mechanical input speed <sup>(3)</sup>	n <sub>1max</sub>	rpm	10000	10000	8500		6500

Output torques			PLN070	PLN090	PLN115	PLN142	PLN190	i <sup>(1)</sup>	p <sup>(2)</sup>
Emergency stop torque <sup>(4)(5)</sup>	T <sub>2Stop</sub>	Nm (lb <sub>r</sub> .in)	60 (531)	150 (1328)	375 (3319)	850 (7523)	1890 (16728)	3	1
			80 (708)	200 (1770)	500 (4425)	1140 (10090)	2520 (22304)	4	
			100 (885)	250 (2213)	620 (5487)	1420 (12568)	3150 (27880)	5	
			80 (708)	175 (1549)	340 (3009)	1300 (11506)	2210 (19560)	7	
			90 (797)	200 (1770)	380 (3363)	970 (8585)	2440 (21596)	8	
			52 (460)	121 (1071)	295 (2611)	570 (5045)	1350 (11949)	10	
		135 (1195)	220 (1947)	500 (4425)	1500 (13276)	3000 (26552)	12	2	
		135 (1195)	220 (1947)	500 (4425)	1500 (13276)	3000 (26552)	15		
		150 (1328)	300 (2655)	650 (5753)	2000 (17701)	3600 (31863)	16		
		150 (1328)	300 (2655)	650 (5753)	2000 (17701)	3600 (31863)	20		
		150 (1328)	300 (2655)	650 (5753)	1800 (15931)	3600 (31863)	25		
		150 (1328)	300 (2655)	650 (5753)	2000 (17701)	3600 (31863)	32		
		150 (1328)	300 (2655)	650 (5753)	1800 (15931)	3600 (31863)	40		
		80 (708)	200 (1770)	380 (3363)	970 (8585)	2440 (21596)	64		
		50 (443)	120 (1062)	240 (2124)	560 (4956)	1350 (11949)	100		

(1) Ratios (i=n<sub>1</sub>/n<sub>2</sub>)  
 (2) Number of stages  
 (3) Application specific configuration with NCP – www.neugart.com  
 (4) Based on reference clamping system diameter  
 (5) Permitted 1000 times

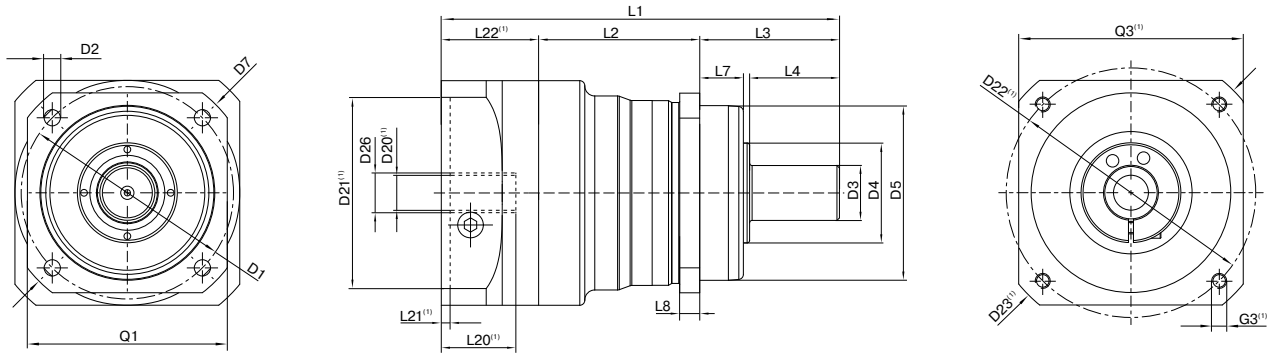

Drawing corresponds to a PLN090 / 1-stage / smooth output shaft / 19 mm clamping system / motor adaptation – 2-part – round universal flange / B5 flange type motor

<sup>(1)</sup> The dimensions vary with the motor/gearbox flange. The input flange dimensions can be retrieved for each specific motor in Tec Data Finder at [www.neugart.com](http://www.neugart.com)

Geometry <sup>(2)</sup>			PLN070	PLN090	PLN115	PLN142	PLN190	p <sup>(3)</sup>	Code
Pitch circle diameter output	D1		68 (2.677) - 75 (2.953)	85 (3.346)	120 (4.724)	165 (6.496)	215 (8.465)		
Mounting bore output	D2	4x	5.5 (0.217)	6.5 (0.256)	9.0 (0.354)	11.0 (0.433)	13.5 (0.531)		
Shaft diameter output	D3	k6	16 (0.630)	22 (0.866)	32 (1.260)	40 (1.575)	55 (2.165)		
Shaft collar output	D4		35 (1.378)	40 (1.575)	45 (1.772)	70 (2.756)	80 (3.150)		
Centering diameter output	D5	g7	60 (2.362)	70 (2.756)	90 (3.543)	130 (5.118)	160 (6.299)		
Diagonal dimension output	D7		92 (3.622)	100 (3.937)	140 (5.512)	185 (7.283)	240 (9.449)		
Flange cross section output	Q1	■	70 (2.756)	80 (3.150)	110 (4.331)	142 (5.591)	190 (7.480)		
Min. total length	L1		137.5 (5.413)	159.5 (6.280)	201 (7.913)	276 (10.866)	310.5 (12.224)	1	
			166.5 (6.555)	191.5 (7.539)	241 (9.488)	335 (13.189)	382.5 (15.059)	2	
Housing length	L2		58.5 (2.303)	64.5 (2.539)	61 (2.402)	91.5 (3.602)	116 (4.567)	1	
			88 (3.465)	96.5 (3.799)	101.5 (3.996)	150.5 (5.925)	188 (7.402)	2	
Centering depth output	L7		19 (0.748)	17.5 (0.689)	28 (1.102)	28 (1.102)	28 (1.102)		
Flange thickness output	L8		7 (0.276)	8 (0.315)	10 (0.394)	12 (0.472)	15 (0.591)		
Motor shaft diameter j6/k6	D20		More information on page 191/192						
Clamping system diameter input	D26		More information on page 130						
Output shaft with feather key (DIN 6885-1)			A 5x5x25	A 6x6x28	A 10x8x50	A 12x8x65	A 16x10x70		
Feather key width (DIN 6885-1)	B1		5 (0.197)	6 (0.236)	10 (0.394)	12 (0.472)	16 (0.630)		
Shaft height including feather key (DIN 6885-1)	H1		18 (0.709)	24,5 (0.965)	35 (1.378)	43 (1.693)	59 (2.323)		
Shaft length output	L3		48 (1.890)	56 (2.205)	88 (3.465)	110 (4.331)	112 (4.409)		<b>A</b>
Shaft length from shoulder	L4		28 (1.102)	36 (1.417)	58 (2.283)	80 (3.150)	82 (3.228)		
Feather key length	L5		25 (0.984)	28 (1.102)	50 (1.969)	65 (2.559)	70 (2.756)		
Distance from shaft end	L6		2 (0.079)	4 (0.157)	4 (0.157)	8 (0.315)	6 (0.236)		
Center hole (DIN 332, type DR)	C		M5x12.5	M8x19	M12x28	M16x36	M20x42		
Smooth output shaft									
Shaft length output	L3		48 (1.890)	56 (2.205)	88 (3.465)	110 (4.331)	112 (4.409)		<b>B</b>
Shaft length from shoulder	L4		28 (1.102)	36 (1.417)	58 (2.283)	80 (3.150)	82 (3.228)		
Splined output shaft (DIN 5480)			W16x0.8x18x6m	W22x1.25x16x6m	W32x1.25x24x6m	W40x2.0x18x6m	W55x2.0x26x6m		
Width of gearing	L <sub>v</sub>		15 (0.591)	15 (0.591)	15 (0.591)	20 (0.787)	22 (0.866)		
Shaft length output	L3		46 (1.811)	46 (1.811)	55.5 (2.185)	70 (2.756)	71 (2.795)		<b>C</b>
Shaft length from shoulder	L4		26 (1.024)	26 (1.024)	26 (1.024)	40 (1.575)	41,5 (1.634)		
Center hole (DIN 332, type DR)	C		M5x12.5	M8x19	M12x28	M16x36	M20x42		

<sup>(2)</sup> Dimensions in mm

<sup>(3)</sup> Number of stages