



# PFHE

## Das Planetengetriebe mit Flansch-Abtriebswelle für High-Load-Applikationen

Das **PFHE** bietet eine preislich attraktive Alternative für High-Load-Applikationen, bei denen hohe Radiallasten auftreten. Die speziellen, vorgespannten Schrägrollenlager in Kombination mit einer Flanschabtriebswelle nach ISO 9409-1 machen das **PFHE** hoch belastbar. Dank des verwendeten Radialwellendichtrings erreicht dieses Getriebe abtriebsseitig die Schutzklasse IP65 und trotz damit auch widrigen Einsatzbedingungen.

Zyklusdrehmoment Cyclic torque	<b>15 - 260 Nm</b>
Radialkraft Radial force	<b>2300 - 5150 N</b>
Axialkraft Axial force	<b>2850 - 6450 N</b>
Verdrehspiel Torsional backlash	<b>7 - 12 arcmin</b>
Schutzart Protection class	<b>IP65</b>

## The planetary gearbox with flange output shaft for high-load applications

The **PFHE** represents an economically attractive alternative for high-load applications in which high radial loads occur. The combination of special pre-stressed inclined roller bearings and a flanged output shaft in accordance with ISO 9409-1 gives the **PFHE** a very high load capacity. Thanks to the radial shaft seal that is used, this gearbox achieves protection class IP65 at the output side and can therefore also withstand adverse usage conditions.

Baugrößen  
Frame sizes

<b>64</b>	<b>90</b>	<b>110</b>
-----------	-----------	------------



Economy Line  
Economy Line

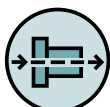

Koaxialgetriebe  
Coaxial gearbox



Geradverzahnt  
Spur gear



Vorgespannte Schrägrollenlager  
Preloaded angular contact roller bearings



Flanschabtriebswelle (ISO 9409-1)  
Flange output shaft (ISO 9409-1)



Option: Ritzel-Zahnstange  
Planetengetriebe (Details auf Seite 158)  
Option: Rack and pinion  
Planetary gearbox (Details on page 158)

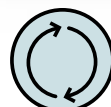

Drehrichtung gleichsinnig  
Equidirectional rotation

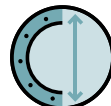

Runder, extra großer Abtriebsflansch  
Extra large round type output flange



Radialwellendichtring  
Rotary shaft seal



Planetenträger in Scheibenausführung  
Planet carrier in disc design



Option: Lackierte Oberfläche  
– RAL 9005 Tiefschwarz  
Option: Painted surface  
– RAL 9005 Jet black

Detaillierte Erläuterungen der technischen Features ab Seite 201.  
Detailed explanations of the technical features starting on page 201.

Code	Getriebekennwerte	Gearbox characteristics			PFHE064	PFHE090	PFHE110	p <sup>(1)</sup>
	Lebensdauer <sup>(2)</sup>	Service life <sup>(2)</sup>	L <sub>n</sub>	h	20.000			
	Wirkungsgrad <sup>(3)</sup>	Efficiency <sup>(3)</sup>	η	%	97			
	Betriebstemperatur min.	Min. operating temperature	T <sub>min</sub>	°C	-25			
	Betriebstemperatur max.	Max. operating temperature	T <sub>max</sub>		90			
	Schutzart	Protection class			IP65			
<b>S</b>	Standard Schmierung	Standard lubrication			Fett (lebensdauergeschmiert) / Grease (lifetime lubrication)			
<b>F</b>	Lebensmitteltaugliche Schmierung	Food grade lubrication			Fett (lebensdauergeschmiert) / Grease (lifetime lubrication)			
	Einbaulage	Installation position			Beliebig / Any			
<b>S</b>	Standard Verdrehspiel	Standard backlash	φ	arcmin	< 10	< 7	< 7	1
					< 12	< 9	< 9	2
	Verdrehsteifigkeit <sup>(3)</sup>	Torsional stiffness <sup>(3)</sup>	C <sub>2t</sub>	Nm / arcmin	5,4 - 10,3	16,1 - 32,5	37,0 - 77,0	1
					5,0 - 11,5	15,7 - 38,5	30,0 - 95,0	2
	Getriebegewicht <sup>(3)</sup>	Gearbox weight <sup>(3)</sup>	m	kg	1,1	3,1	5,9 - 6,1	1
					1,3 - 1,4	3,5 - 3,8	7,6 - 8,1	2
<b>S</b>	Standard Oberfläche	Standard surface			Gehäuse: Stahl – wärmebehandelt und nachoxidiert (schwarz) Housing: Steel – heat-treated and post-oxidized (black)			
<b>B</b>	Lackierte Oberfläche <sup>(4)</sup>	Painted surface <sup>(4)</sup>			RAL 9005 Tiefschwarz RAL 9005 Jet black			
	Laufgeräusch <sup>(3)</sup>	Running noise <sup>(3)</sup>	L <sub>pA</sub>	dB(A)	60	62	65	

Abtriebswellenbelastungen	Output shaft loads			PFHE064	PFHE090	PFHE110	p <sup>(1)</sup>
Maximale Radialkraft	Maximum radial force	F <sub>r max</sub>	N	2300	4100	5150	
Maximale Axialkraft	Maximum axial force	F <sub>a max</sub>		2850	5450	6450	
Maximales Kippmoment	Maximum tilting moment	M <sub>K max</sub>	Nm	110	278	407	

Antriebskennwerte	Input characteristics			PFHE064	PFHE090	PFHE110	p <sup>(1)</sup>
Durchmesser Spannsystem am Antrieb (Code)	Clamping system diameter input (Code)	D26	mm	11 (C)	19 (E) <sup>(5)</sup>	24 (F) <sup>(5)</sup>	
				14 (D) <sup>(5)</sup>	24 (F)	35 (G)	
				19 (E)	-	-	
Massenträgheitsmoment Antrieb <sup>(3)(5)</sup>	Mass moment of inertia input <sup>(3)(5)</sup>	J <sub>i</sub>	kgcm <sup>2</sup>	0,094 - 0,245	0,407 - 1,170	1,505 - 3,658	1
				0,084 - 0,152	0,356 - 0,667	1,377 - 2,432	2
Mittleres Leerlaufdrehmoment <sup>(3)(5)</sup>	Average idle torque <sup>(3)(5)</sup>	T <sub>0</sub>	Nm	0,25 - 0,85	0,45 - 1,75	0,80 - 3,65	1
				0,15 - 0,30	0,20 - 0,55	0,30 - 1,15	2
Maximales Biegemoment am Antrieb	Maximum bending moment input	M <sub>b1</sub>		8	16	40	

<sup>(1)</sup> Anzahl Getriebestufen

<sup>(2)</sup> Applikationsspezifische Auslegung mit NCP – www.neugart.com

<sup>(3)</sup> Die übersetzungsabhängigen Werte sind im Tec Data Finder abrufbar – www.neugart.com

<sup>(4)</sup> Weitere Informationen auf Seite 183

<sup>(5)</sup> Referenz Spannsystemdurchmesser

<sup>(1)</sup> Number of stages

<sup>(2)</sup> Application specific configuration with NCP – www.neugart.com

<sup>(3)</sup> The ratio-dependent values can be retrieved in Tec Data Finder – www.neugart.com

<sup>(4)</sup> More information on page 183

<sup>(5)</sup> Reference clamping system diameter

Abtriebsdrehmomente	Output torques			PFHE064	PFHE090	PFHE110	i <sup>(1)</sup>	p <sup>(2)</sup>
Zyklusdrehmoment <sup>(3)(4)</sup>	Cyclic torque <sup>(3)(4)</sup>	T <sub>2z</sub>	Nm	28	85	115	3	1
				38	115	155	4	
				40	110	195	5	
				25	65	135	7	
				18	50	120	8	
				15	38	95	10	
				44	130	210	9	2
				44	120	260	12	
				44	110	230	15	
				44	120	260	16	
				44	120	260	20	
				40	110	230	25	
				44	120	260	32	
				40	110	230	40	
				18	50	120	64	
				15	38	95	100	
Maximales Drehmoment <sup>(3)(4)</sup>	Maximum torque <sup>(3)(4)</sup>	T <sub>2max</sub>	Nm	44	105	184	3	1
				60	140	245	4	
				61	175	310	5	
				40	104	215	7	
				28	80	192	8	
				24	60	152	10	
				70	182	335	9	2
				65	192	415	12	
				70	176	365	15	
				65	192	415	16	
				65	192	415	20	
				61	176	365	25	
				65	192	415	32	
				61	176	365	40	
				28	80	192	64	
				24	60	152	100	

PFHE

<sup>(1)</sup> Übersetzungen (i=n<sub>1</sub>/n<sub>2</sub>)

<sup>(2)</sup> Anzahl Getriebestufen

<sup>(3)</sup> Applikationsspezifische Auslegung mit NCP – www.neugart.com

<sup>(4)</sup> Bezogen auf Referenz Spannsystemdurchmesser

<sup>(1)</sup> Ratios (i=n<sub>1</sub>/n<sub>2</sub>)

<sup>(2)</sup> Number of stages

<sup>(3)</sup> Application specific configuration with NCP – www.neugart.com

<sup>(4)</sup> Based on reference clamping system diameter

Abtriebsdrehmomente	Output torques			PFHE064	PFHE090	PFHE110	i <sup>(1)</sup>	p <sup>(2)</sup>
Dauerdrehmoment <sup>(3)</sup>	Continuous torque <sup>(3)</sup>	T <sub>2D</sub>	Nm	23	38	97	3	1
				23	88	131	4	
				24	87	165	5	
				19,5	55	114	7	
				15	42	102	8	
				12,5	32	80	10	
				30	87	178	9	2
				32	102	220	12	
				35	93	195	15	
				35	102	220	16	
				37	102	220	20	
				34	93	195	25	
				37	102	220	32	
				34	93	195	40	
				15	42	102	64	
				12,5	32	80	100	

Antriebsdrehzahlen	Input speeds			PFHE064	PFHE090	PFHE110	i <sup>(1)</sup>	p <sup>(2)</sup>
Dauerantriebsdrehzahl <sup>(3)(4)</sup>	Continuous input speed <sup>(3)(4)</sup>	n <sub>1D</sub>	min <sup>-1</sup>	3800	3750	1550	3	1
				4500	2950	1750	4	
				4500	3550	1950	5	
				4500	4000	2750	7	
				4500	4000	3450	8	
				4500	4000	3500	10	
				4500	4000	1700	9	2
				4500	4000	2000	12	
				4500	4000	2450	15	
				4500	4000	2400	16	
				4500	4000	2750	20	
				4500	4000	3500	25	
				4500	4000	3500	32	
				4500	4000	3500	40	
				4500	4000	3500	64	
				4500	4000	3500	100	
Max. mechanische Antriebsdrehzahl <sup>(3)</sup>	Max. mechanical input speed <sup>(3)</sup>	n <sub>1max</sub>	min <sup>-1</sup>	7500	7000	6500		

Abtriebsdrehmomente	Output torques			PFHE064	PFHE090	PFHE110	i <sup>(1)</sup>	p <sup>(2)</sup>
Not-Aus Drehmoment <sup>(4)(5)</sup>	Emergency stop torque <sup>(4)(5)</sup>	T <sub>2Stop</sub>	Nm	60	150	375	3	1
				80	200	500	4	
				80	220	500	5	
				80	178	340	7	
				80	190	380	8	
				75	200	480	10	
				88	260	500	9	2
				88	240	520	12	
				88	220	500	15	
				88	240	520	16	
				88	240	520	20	
				80	220	500	25	
				88	240	520	32	
				80	220	500	40	
				80	190	380	64	
				75	200	480	100	

<sup>(1)</sup> Übersetzungen (i=n<sub>1</sub>/n<sub>2</sub>)

<sup>(2)</sup> Anzahl Getriebestufen

<sup>(3)</sup> Applikationsspezifische Auslegung mit NCP – www.neugart.com

<sup>(4)</sup> Bezogen auf Referenz Spannsystemdurchmesser

<sup>(5)</sup> 1000-mal zulässig

<sup>(1)</sup> Ratios (i=n<sub>1</sub>/n<sub>2</sub>)

<sup>(2)</sup> Number of stages

<sup>(3)</sup> Application specific configuration with NCP – www.neugart.com

<sup>(4)</sup> Based on reference clamping system diameter

<sup>(5)</sup> Permitted 1000 times

PFHE064  
PFHE090

PFHE110

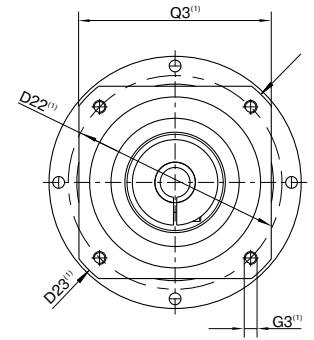
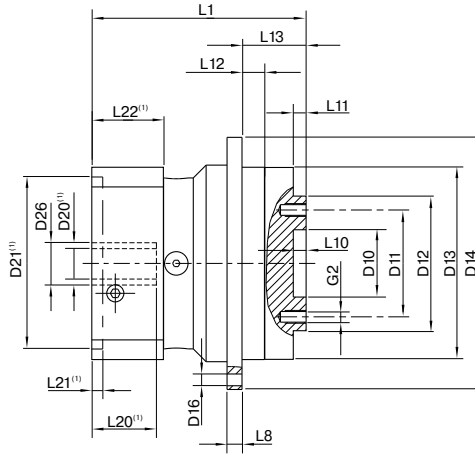
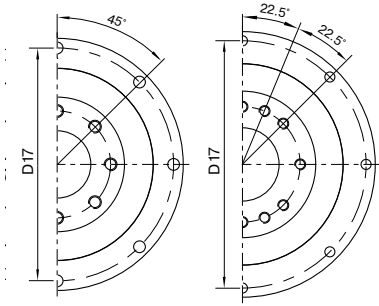

Darstellung entspricht einem PFHE090 / 1-stufig / Flansch-Abtriebswelle / 19 mm Spannsystem / Motoranpassung – einteilig / B5 Flanschtyp Motor  
Drawing corresponds to a PFHE090 / 1-stage / flange output shaft / 19 mm clamping system / motor adaptation – one part / B5 flange type motor

<sup>(1)</sup> Die Maße variieren je nach Motor-/Getriebeflansch. Die motorspezifischen Antriebsflansch-Geometrien können im Tec Data Finder für jeden Motor gezielt abgerufen werden - www.neugart.com  
<sup>(1)</sup> The dimensions vary with the motor/gearbox flange. The input flange dimensions can be retrieved for each specific motor in Tec Data Finder at www.neugart.com

Geometrie <sup>(2)</sup>	Geometry <sup>(2)</sup>			PFHE064	PFHE090	PFHE110	p <sup>(3)</sup>	Code
Zentrierdurchmesser Abtriebswelle	Centering diameter output shaft	D10	H7	20	31,5	40		
Lochkreisdurchmesser Abtriebswelle	Pitch circle diameter output shaft	D11		31,5	50	63		
Zentrierbunddurchmesser Abtriebswelle	Centering diameter output shaft	D12	h7	40	63	80		
Zentrierbunddurchmesser Abtriebsflansch	Centering diameter output flange	D13		64	90	110		
Flanschdurchmesser Abtrieb	Flange diameter output	D14		86	118	145		
Montagebohrung Abtrieb	Mounting bore output	D16		4,5 8x45°	5,5 8x45°	5,5 8x45°		
Lochkreisdurchmesser Abtriebsflansch	Pitch circle diameter output flange	D17		79	109	135		
Min. Gesamtlänge	Min. total length	L1		72	100,5	117	1	
				84,5	118	144	2	
Flanschdicke Abtrieb	Flange thickness output	L8		4	7	8		
Zentriertiefe Abtriebswelle	Centering depth output shaft	L10		4	6	6		
Zentrierbundtiefe Abtriebswelle		L11		3	6	7		
Zentrierbundtiefe Abtriebsflansch	Centering depth output flange	L12		7,5	10,5	10,5		
Abtriebsflanschlänge	Output flange length	L13		19,5	30	29		
Durchmesser Motorwelle j6/k6	Motor shaft diameter j6/k6	D20		Weitere Informationen auf Seite 191/192 More information on page 191/192				
Durchmesser Spannsystem am Antrieb	Clamping system diameter input	D26		Weitere Informationen auf Seite 54 More information on page 54				
Flansch-Abtriebswelle (ähnlich ISO 9409-1)	Flange output shaft (similar ISO 9409-1)							<b>D</b>
Anzahl x Gewinde x Tiefe	Number x thread x depth	G2		8 x M5x7	8 x M6x10	12 x M6x12		

<sup>(2)</sup> Maße in mm  
<sup>(3)</sup> Anzahl Getriebestufen

<sup>(2)</sup> Dimensions in mm  
<sup>(3)</sup> Number of stages