



WGN

The hypoid-toothed right-angle gearbox with hollow shaft – low-noise and force-fit mounting

Our **WGN** is the right-angle hollow shaft gearbox that operates particularly quietly. At the same time, the hypoid gearing increases the quality of the surface of your workpiece. With a shrink disc, it can be connected directly to the application - this is uncomplicated, safe and opens up new design possibilities.

Nominal output torque **22 - 320 Nm**



Radial force **2700 - 10000 N**



Axial force **4300 - 14500 N**



Torsional backlash **5 arcmin**



Protection class **IP65**



Frame sizes

- 70
- 90
- 115
- 142

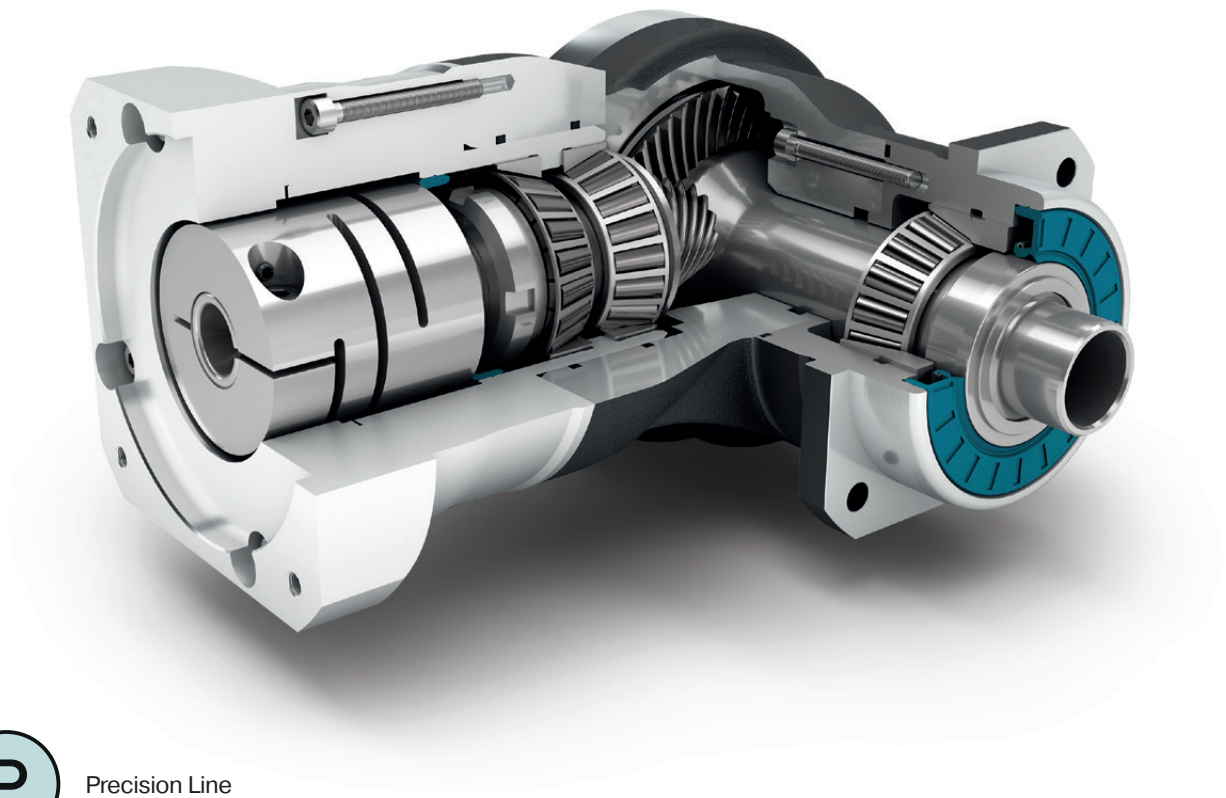

Precision Line



Right angle gearbox



Hypoid gear right angle stage



Preloaded tapered roller bearings

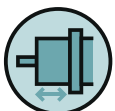

Extra long centering collar



Counterdirectional rotation



Square type output flange



Rotary shaft seal



Hollow shaft for clamping system with shrink disc

Detailed explanations of the technical features starting on page 173.

Code	Gearbox characteristics			WGN070	WGN090	WGN115	WGN142	p ⁽¹⁾
	Service life (L _{10h})	t _L	h	20,000				
	Service life at T _{2N} × 0,88			30,000				
	Efficiency at full load ⁽²⁾	η	%	95				
	Min. operating temperature	T _{min}	°C	-25 (-13)				
	Max. operating temperature	T _{max}	(°F)	90 (194)				
	Protection class			IP65				
S	Standard lubrication			Oil (lifetime lubrication)				
F	Food grade lubrication			Oil (lifetime lubrication)				
	Installation position			Any				
S	Standard backlash	j _t	arcmin	< 5				
R	Reduced backlash			-				
	Torsional stiffness ⁽²⁾	c _g	Nm /arcmin (lb _f .in / arcmin)	1.6 - 2.2 (14 - 19)	4.2 - 5.7 (37 - 50)	9.2 - 12.4 (81 - 110)	23.5 - 31.5 (208 - 279)	
	Gearbox weight ⁽²⁾	m _G	kg (lb _m)	3.2 - 3.3 (7.1 - 7.2)	5.1 - 5.6 (11.3 - 12.3)	10.9 (24.0)	23.3 - 23.8 (51.3 - 52.5)	
S	Standard surface			Right angle housing: Aluminum – anodized (black)				
	Running noise ⁽³⁾	Q _g	dB(A)	66	67	68	70	
	Max. bending moment based on the gearbox input flange ⁽⁴⁾	M _b	Nm (lb _f .in)	12 (106)	25.5 (226)	53 (469)	120 (1062)	

Output shaft loads			WGN070	WGN090	WGN115	WGN142	p ⁽¹⁾
Radial force for 20,000 h ⁽⁵⁾⁽⁶⁾	F _{r 20.000 h}	N (lb _f)	2700 (607)	4000 (899)	6500 (1461)	10000 (2248)	
Axial force for 20,000 h ⁽⁵⁾⁽⁶⁾	F _{a 20.000 h}		4300 (967)	5900 (1326)	7000 (1574)	14500 (3260)	
Radial force for 30,000 h ⁽⁵⁾⁽⁶⁾	F _{r 30.000 h}		2700 (607)	4000 (899)	6500 (1461)	10000 (2248)	
Axial force for 30,000 h ⁽⁵⁾⁽⁶⁾	F _{a 30.000 h}		3700 (832)	5200 (1169)	6100 (1371)	12000 (2698)	
Maximum radial force ⁽⁶⁾⁽⁷⁾	F _{r Stat}		2700 (607)	4000 (899)	6500 (1461)	10000 (2248)	
Maximum axial force ⁽⁶⁾⁽⁷⁾	F _{a Stat}		4300 (967)	5900 (1326)	7000 (1574)	14500 (3260)	
Tilting moment for 20,000 h ⁽⁵⁾⁽⁷⁾	M _{K 20.000 h}	Nm (lb _f .in)	252 (2230)	442 (3912)	970 (8585)	1505 (13320)	
Tilting moment for 30,000 h ⁽⁵⁾⁽⁷⁾	M _{K 30.000 h}		252 (2230)	442 (3912)	970 (8585)	1505 (13320)	

Moment of inertia			WGN070	WGN090	WGN115	WGN142	p ⁽¹⁾
Mass moment of inertia ⁽²⁾	J	kgcm ² (lb _f .in.s ² 10 ⁻⁴)	0.502 - 0.834 (4.443 - 7.382)	1.018 - 1.417 (9.010 - 12.542)	4.805 - 6.111 (42.528 - 54.087)	12.934 - 18.905 (114.476 - 167.323)	

(1) Number of stages
 (2) The ratio-dependent values can be retrieved in Tec Data Finder – www.neugart.com
 (3) Sound pressure level from 1 m, measured on input running at n_i=3000 rpm no load; i=5
 (4) Max. motor weight* in kg = 0.2 × M_b / motor length in m
 * with symmetrically distributed motor weight
 * with horizontal and stationary mounting
 (5) These values are based on an output shaft speed of n₂=100 rpm
 (6) Based on center of output shaft
 (7) Other (sometimes higher) values following changes to T_{2N}, F_r, F_a, cycle, and service life of bearing. Application specific configuration with NCP – www.neugart.com

Output torques			WGN070	WGN090	WGN115	WGN142	i ⁽¹⁾	p ⁽²⁾
Nominal output torque ⁽³⁾	T _{2N}	Nm (lb.in)	45 (398)	70 (620)	140 (1239)	320 (2832)	4	1
			42 (372)	70 (620)	140 (1239)	280 (2478)	5	
			28 (248)	51 (451)	91 (805)	189 (1673)	7	
			27 (239)	50 (443)	90 (797)	180 (1593)	8	
			22 (195)	40 (354)	75 (664)	160 (1416)	10	
Max. output torque ⁽⁴⁾	T _{2max}	Nm (lb.in)	72 (637)	112 (991)	224 (1983)	512 (4532)	4	
			67 (593)	112 (991)	224 (1983)	448 (3965)	5	
			45 (398)	82 (726)	145 (1283)	302 (2673)	7	
			43 (381)	80 (708)	144 (1275)	288 (2549)	8	
			35 (310)	64 (566)	120 (1062)	256 (2266)	10	
Emergency stop torque ⁽⁵⁾	T _{2Stop}	Nm (lb.in)	100 (885)	200 (1770)	400 (3540)	800 (7081)	4	
			100 (885)	200 (1770)	400 (3540)	800 (7081)	5	
			75 (664)	150 (1328)	300 (2655)	700 (6196)	7	
			75 (664)	150 (1328)	300 (2655)	700 (6196)	8	
			75 (664)	150 (1328)	300 (2655)	700 (6196)	10	

Input speeds			WGN070	WGN090	WGN115	WGN142	i ⁽¹⁾	p ⁽²⁾
Average thermal input speed at T _{2N} and S1 ⁽⁴⁾⁽⁵⁾	n _{1N}	rpm	1750 ⁽⁶⁾	1700 ⁽⁶⁾	1150 ⁽⁶⁾	950 ⁽⁶⁾	4	1
			1900 ⁽⁶⁾	1850 ⁽⁶⁾	1200 ⁽⁶⁾	1000 ⁽⁶⁾	5	
			2250 ⁽⁶⁾	2200 ⁽⁶⁾	1400 ⁽⁶⁾	1200 ⁽⁶⁾	7	
			2300 ⁽⁶⁾	2200 ⁽⁶⁾	1400 ⁽⁶⁾	1200 ⁽⁶⁾	8	
			2400 ⁽⁶⁾	2350 ⁽⁶⁾	1500 ⁽⁶⁾	1300 ⁽⁶⁾	10	
Max. mechanical input speed ⁽⁴⁾	n _{1Limit}	rpm	16,000	14,000	9500	8000		

⁽¹⁾ Ratios (i=n₁/n₂)

⁽²⁾ Number of stages

⁽³⁾ Application specific configuration with NCP – www.neugart.com

⁽⁴⁾ 30,000 rotations of the output shaft permitted; see page 166

⁽⁵⁾ Permitted 1000 times

⁽⁶⁾ Application-specific speed configurations with NCP – www.neugart.com

⁽⁷⁾ See page 166 for the definition

⁽⁸⁾ Average thermal input speed at 50% T_{2N} and S1

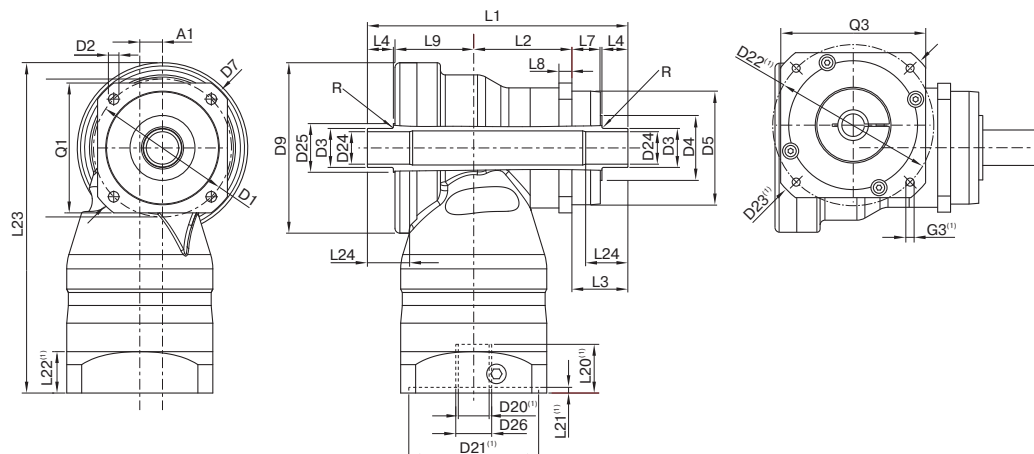

Drawing corresponds to a WGN090 / 1-stage / hollow output shaft on both sides / 19 mm clamping system / motor adaptation – 2-part – round universal flange / B5 flange type motor

⁽¹⁾ The dimensions vary with the motor/gearbox flange. The input flange dimensions can be retrieved for each specific motor in Tec Data Finder at www.neugart.com

Geometry ⁽²⁾			WGN070	WGN090	WGN115	WGN142	p ⁽³⁾	Code	
Axis offset	A1		10 (0.394)	14 (0.551)	20 (0.787)	26 (1.024)	1		
Pitch circle diameter output	D1		68 - 75 (2.677 - 2.953)	85 (3.346)	120 (4.724)	165 (6.496)			
Mounting bore output	D2	4x	5.5 (0.217)	6.5 (0.256)	9.0 (0.354)	11.0 (0.433)			
Shaft diameter output	D3	h8	18 (0.709)	24 (0.945)	36 (1.417)	50 (1.969)			
Shaft collar output	D4		30 (1.181)	34 (1.339)	45 (1.772)	70 (2.756)			
Centering diameter output	D5	g7	60 (2.362)	70 (2.756)	90 (3.543)	130 (5.118)			
Diagonal dimension output	D7		92 (3.622)	100 (3.937)	140 (5.512)	185 (7.283)			
Max. diameter	D9		86 (3.386)	105 (4.134)	120 (4.724)	170 (6.693)			
Flange cross section output	Q1	■	70 (2.756)	80 (3.150)	110 (4.331)	142 (5.591)			
Housing length	L2		46.5 (1.831)	60.5 (2.382)	73.5 (2.894)	76 (2.992)			
Shaft length output	L3		33 (1.299)	34.5 (1.358)	48 (1.890)	54 (2.126)			
Centering depth output	L7		18 (0.709)	17.5 (0.689)	27 (1.063)	28 (1.102)			
Flange thickness output	L8		7 (0.276)	8 (0.315)	10 (0.394)	12 (0.472)			
Offset length	L9		43 (1.693)	48.5 (1.909)	56.5 (2.224)	87 (3.425)			
Min. overall height	L23		179 (7.047)	203.5 (8.012)	247.5 (9.744)	318 (12.520)			
Max. radius	R		1.5 (0.059)						
Motor shaft diameter j6/k6	D20		More information on page 163/164						
Clamping system diameter input	D26								
Hollow output shaft on one side									F
Hollow shaft diameter	D24	H6	15 (0.591)	20 (0.787)	30 (1.181)	40 (1.575)			
Total length	L1		122.5 (4.823)	143.5 (5.650)	178 (7.008)	217 (8.543)			
Shaft length from shoulder	L4		14 (0.551)	16 (0.630)	20 (0.787)	25 (0.984)			
Min. fit length	L24		20 (0.787)	25 (0.984)	30 (1.181)	35 (1.378)			
Hollow output shaft on both sides							G		
Hollow shaft diameter	D24	H6	15 (0.591)	20 (0.787)	30 (1.181)	40 (1.575)			
Shaft collar	D25		25 (0.984)	30 (1.181)	42 (1.654)	55 (2.165)			
Total length	L1		137.5 (5.413)	160.5 (6.319)	199 (7.835)	243 (9.567)			
Shaft length from shoulder	L4		14 (0.551)	16 (0.630)	20 (0.787)	25 (0.984)			
Min. fit length	L24		20 (0.787)	25 (0.984)	30 (1.181)	35 (1.378)			

⁽²⁾ Dimensions in mm

⁽³⁾ Number of stages

WGN Shrink disc

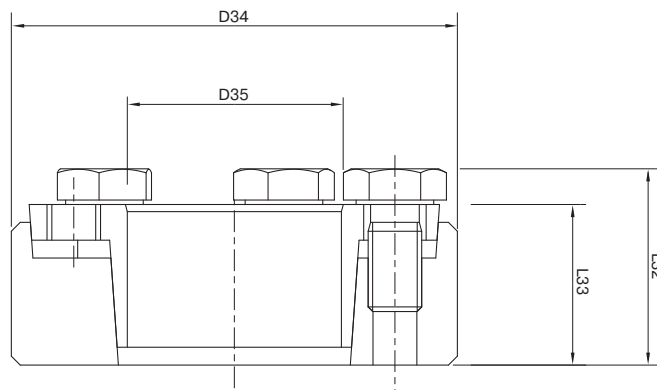

This shrink disc can be used to make a force-fit connection between your machine shaft and the right angle hollow shaft gearbox WGN.

			WGN070	WGN090	WGN115	WGN142
Art. No.			58365	58366	58367	58368
Outside diameter	D34	mm (in)	44 (1.732)	50 (1.968)	72 (2.835)	90 (3.543)
Inner diameter	D35		18 (0.709)	24 (0.945)	36 (1.417)	50 (1.968)
Overall length ⁽¹⁾	L32		19 (0.748)	22 (0.866)	27.3 (1.075)	31.3 (1.232)
Clamp length ⁽¹⁾	L33		15 (0.591)	18 (0.709)	22 (0.866)	26 (1.024)
Width across flats	SW30		10 (0.394)	10 (0.394)	13 (0.512)	13 (0.512)
Number of clamp screws	N30		4 (0.157)	5 (0.197)	5 (0.197)	8 (0.315)
Mass moment of inertia	J	kgcm ² (lb _r .in.s ² 10 ⁻⁴)	0.4251 (3.672)	0.7831 (6.930)	4.212 (37.276)	11.55 (102.218)

For the load shaft, we recommend a tolerance of h6 and a surface roughness of Ra < 3.2 µm. CAD data can be accessed at www.neugart.com

For correct installation of the shrink disc, please refer to the corresponding mounting instructions (www.neugart.com)

Included parts

1 x Shrink disc (incl. screws)

⁽¹⁾ Dimensions in unclamped state