

PLE

Unerreicht: Dieses Planetengetriebe ist maximal effizient auch bei höchsten Drehzahlen

Das **PLE** ist unser Preis-Leistungs-Wunder. Es ist besonders leicht, leistungsstark und dank seines reibungsarmen Lagerkonzepts und der optimierten Schmierung dennoch für anspruchsvolle Produktionszyklen geeignet. Ein echtes Kraftpaket zu einem attraktiven und fairen Preis.

Unparalleled: This planetary gearbox maintains its maximum efficiency even at the highest speeds

The **PLE** is our price/performance wonder. It is particularly lightweight, extremely powerful and yet still suitable for demanding production cycles thanks to its low-friction bearing concept and optimized lubrication. A real powerhouse at an attractive and fair price.

Nenn-Abtriebsdrehmoment
Nominal output torque **5 - 800 Nm**

Radialkraft
Radial force **200 - 5000 N**

Axialkraft
Axial force **200 - 7000 N**

Verdrehspiel
Torsional backlash **6 - 22 arcmin**

Schutzart
Protection class **IP54**

Baugrößen
Frame sizes

- 40
- 60
- 80
- 120
- 160

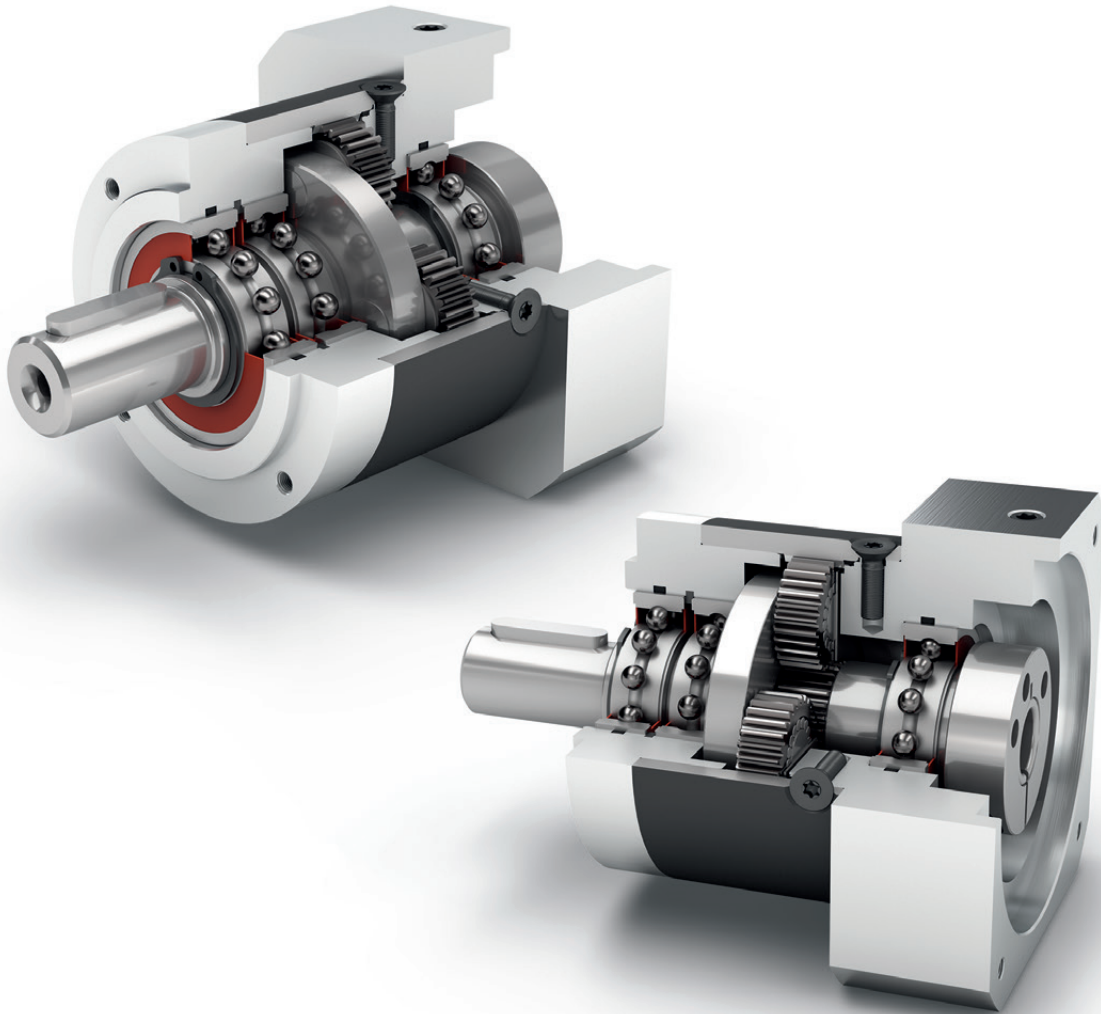

Economy Line
Economy Line



Drehrichtung gleichsinnig
Equidirectional rotation



Runder Abtriebsflansch
Round type output flange



Hohe Übersetzungsvielfalt $i=3$ bis $i=512$
High ratio variety $i=3$ up to $i=512$

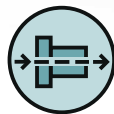

Koaxialgetriebe
Coaxial gearbox



Geradverzahnt
Spur gear



Reibungsarme Rillenkugellager
Low-friction deep groove ball bearings



Planetenträger in Scheibenausführung
Planet carrier in disc design

Detaillierte Erläuterungen der technischen Features ab Seite 173.
Detailed explanations of the technical features starting on page 173.

Code	Getriebekennwerte	Gearbox characteristics			PLE040	PLE060	PLE080	PLE120	PLE160	p ⁽¹⁾
	Lebensdauer (L _{10h})	Service life (L _{10h})	t _L	h	30.000					
	Wirkungsgrad bei Vollast ⁽²⁾	Efficiency at full load ⁽²⁾	η	%	98					1
97					2					
92					3					
	Betriebstemperatur min.	Min. operating temperature	T _{min}	°C	-25					
	Betriebstemperatur max.	Max. operating temperature	T _{max}		90					
	Schutzart	Protection class			IP54					
S	Standard Schmierung	Standard lubrication		Fett (lebensdauergeschmiert) / Grease (lifetime lubrication)						
F	Lebensmitteltaugliche Schmierung	Food grade lubrication		Fett (lebensdauergeschmiert) / Grease (lifetime lubrication)						
L	Tieftemperatur Schmierung ⁽³⁾	Low temperature lubrication ⁽³⁾		Fett (lebensdauergeschmiert) / Grease (lifetime lubrication)						
	Einbaulage	Installation position		Beliebig / Any						
S	Standard Verdrehspiel	Standard backlash	j _i	arcmin	< 15	< 10	< 7	< 7	< 6	1
					< 19	< 12	< 9	< 9	< 9	2
					< 22	< 15	< 11	< 11	-	3
	Verdrehsteifigkeit ⁽²⁾	Torsional stiffness ⁽²⁾	c _G	Nm / arcmin	0,7 - 1,0	2,1 - 2,8	7,2 - 10,0	15,5 - 21,0	57,5 - 69,0	1
					0,8 - 1,0	2,3 - 2,8	7,9 - 10,4	17,5 - 22,0	61,0 - 75,0	2
					0,8 - 1,0	2,3 - 2,8	7,9 - 10,5	17,5 - 22,0	-	3
	Getriebegewicht ⁽²⁾	Gearbox weight ⁽²⁾	m _G	kg	0,3 - 0,4	0,9	2,1	5,6 - 5,7	17,4 - 17,6	1
					0,4 - 0,5	1,1	2,6	7,3 - 7,5	23,5 - 23,7	2
					0,5	1,3	3,1	9,2 - 9,4	-	3
S	Standard Oberfläche	Standard surface			Gehäuse: Stahl – wärmebehandelt und nachoxidiert (schwarz) Housing: Steel – heat-treated and post-oxidized (black)					
	Laufgeräusch ⁽⁴⁾	Running noise ⁽⁴⁾	Q _G	dB(A)	58	58	60	65	70	
	Max. Biegemoment bezogen auf den Getriebeantriebsflansch ⁽⁵⁾	Max. bending moment based on the gearbox input flange ⁽⁵⁾	M _b	Nm	4,5	12	16	40	140	

Abtriebswellenbelastungen	Output shaft loads			PLE040	PLE060	PLE080	PLE120	PLE160	p ⁽¹⁾
Radialkraft für 20.000 h ⁽⁶⁾⁽⁷⁾	Radial force for 20,000 h ⁽⁶⁾⁽⁷⁾	F _{r20.000h}	N	200	400	750	1750	5000	
Axialkraft für 20.000 h ⁽⁶⁾⁽⁷⁾	Axial force for 20,000 h ⁽⁶⁾⁽⁷⁾	F _{a20.000h}		200	500	1000	2500	7000	
Radialkraft für 30.000 h ⁽⁶⁾⁽⁷⁾	Radial force for 30,000 h ⁽⁶⁾⁽⁷⁾	F _{r30.000h}		160	340	650	1500	4200	
Axialkraft für 30.000 h ⁽⁶⁾⁽⁷⁾	Axial force for 30,000 h ⁽⁶⁾⁽⁷⁾	F _{a30.000h}		160	450	900	2100	6000	
Maximale Radialkraft ⁽⁷⁾⁽⁸⁾	Maximum radial force ⁽⁷⁾⁽⁸⁾	F _{r Stat}		200	700	1250	2000	5000	
Maximale Axialkraft ⁽⁷⁾⁽⁸⁾	Maximum axial force ⁽⁷⁾⁽⁸⁾	F _{a Stat}		240	800	1600	3800	11000	
Kippmoment für 20.000 h ⁽⁶⁾⁽⁸⁾	Tilting moment for 20,000 h ⁽⁶⁾⁽⁸⁾	M _{K20.000h}	Nm	5	14	31	101	474	
Kippmoment für 30.000 h ⁽⁶⁾⁽⁸⁾	Tilting moment for 30,000 h ⁽⁶⁾⁽⁸⁾	M _{K30.000h}		4	12	27	86	398	

Trägheitsmoment	Moment of inertia			PLE040	PLE060	PLE080	PLE120	PLE160	p ⁽¹⁾
Massenträgheitsmoment ⁽²⁾	Mass moment of inertia ⁽²⁾	J	kgcm ²	0,014	0,065	0,359	1,378	3,726	1
				-	-	-	-	-	
				0,027	0,128	0,654	2,361	11,999	2
				-	-	-	-	-	
				0,015	0,066	0,365	1,414	3,502	3
				0,026	0,121	0,613	2,288	10,087	
0,015	0,066	0,365	1,413	-					
0,025	0,076	0,590	2,196	-					

(1) Anzahl Getriebestufen
 (2) Die übersetzungsabhängigen Werte sind im Tec Data Finder abrufbar – www.neugart.com
 (3) T_{min} = -40°C. Optimale Betriebstemperatur max. 50°C
 (4) Schalldruckpegel in 1 m Abstand; gemessen bei einer Antriebsdrehzahl von n₁=3000 min⁻¹ ohne Last; i=5
 (5) Max. Motorgewicht* in kg = 0.2 x M_b / Motorlänge in m
 * bei symmetrischer Motorgewichtsverteilung
 * bei horizontaler und stationärer Einbaulage
 (6) Die Angaben beziehen sich auf eine Abtriebswellendrehzahl von n₂=100 min⁻¹
 (7) Bezogen auf die Mitte der Abtriebswelle
 (8) Abweichende (teilweise höhere) Werte bei Änderungen von T_{2N}, F_r, F_a, sowie Zyklus und Lagerlebensdauer. Applikationsspezifische Auslegung mit NCP – www.neugart.com

(1) Number of stages
 (2) The ratio-dependent values can be retrieved in Tec Data Finder – www.neugart.com
 (3) T_{min} = -40°C. Optimal operating temperature max. 50°C
 (4) Sound pressure level from 1 m, measured on input running at n₁=3000 rpm no load; i=5
 (5) Max. motor weight* in kg = 0.2 x M_b / motor length in m
 * with symmetrically distributed motor weight
 * with horizontal and stationary mounting
 (6) These values are based on an output shaft speed of n₂=100 rpm
 (7) Based on center of output shaft
 (8) Other (sometimes higher) values following changes to T_{2N}, F_r, F_a, cycle, and service life of bearing. Application specific configuration with NCP – www.neugart.com

Abtriebsdrehmomente	Output torques			PLE040	PLE060	PLE080	PLE120	PLE160	i ⁽¹⁾	p ⁽²⁾
Nenn-Abtriebsdrehmoment ⁽³⁾⁽⁴⁾	Nominal output torque ⁽³⁾⁽⁴⁾	T _{2N}	Nm	11	28	85	115	400	3	1
				15	38	115	155	450	4	
				14	40	110	195	450	5	
				8,5	25	65	135	-	7	
				6	18	50	120	450	8	
				5	15	38	95	-	10	
				16,5	44	130	210	-	9	
				20	44	120	260	800	12	
				18	44	110	230	700	15	
				20	44	120	260	800	16	
				20	44	120	260	800	20	
				18	40	110	230	700	25	
				20	44	120	260	800	32	
				18	40	110	230	700	40	
				7,5	18	50	120	450	64	
				20	44	110	260	-	60	
				20	44	120	260	-	80	
				20	44	120	260	-	100	
				18	44	110	230	-	120	
				20	44	120	260	-	160	
				18	40	110	230	-	200	
				20	44	120	260	-	256	
				18	40	110	230	-	320	
				7,5	18	50	120	-	512	
Max. Abtriebsdrehmoment ⁽⁴⁾⁽⁵⁾	Max. output torque ⁽⁴⁾⁽⁵⁾	T _{2max}	Nm	17,5	45	136	184	640	3	1
				24	61	184	248	720	4	
				22	64	176	312	720	5	
				13,5	40	104	216	-	7	
				10	29	80	192	720	8	
				8	24	61	152	-	10	
				26	70	208	336	-	9	
				32	70	192	416	1280	12	
				29	70	176	368	1120	15	
				32	70	192	416	1280	16	
				32	70	192	416	1280	20	
				29	64	176	368	1120	25	
				32	70	192	416	1280	32	
				29	64	176	368	1120	40	
				12	29	80	192	720	64	
				32	70	176	416	-	60	
				32	70	192	416	-	80	
				32	70	192	416	-	100	
				29	70	176	368	-	120	
				32	70	192	416	-	160	
				29	64	176	368	-	200	
				32	70	192	416	-	256	
				29	64	176	368	-	320	
				12	29	80	192	-	512	

⁽¹⁾ Übersetzungen (i=n₁/n₂)

⁽²⁾ Anzahl Getriebestufen

⁽³⁾ Applikationsspezifische Auslegung mit NCP – www.neugart.com

⁽⁴⁾ Werte bei Passfeder (Code „A“): für schwelende Belastung

⁽⁵⁾ Zulässig für 30.000 Umdrehungen der Abtriebswelle; siehe Seite 166

⁽¹⁾ Ratios (i=n₁/n₂)

⁽²⁾ Number of stages

⁽³⁾ Application specific configuration with NCP – www.neugart.com

⁽⁴⁾ Values for feather key (code "A"): for repeated load

⁽⁵⁾ 30,000 rotations of the output shaft permitted; see page 167

Abtriebsdrehmomente	Output torques			PLE040	PLE060	PLE080	PLE120	PLE160	i ⁽¹⁾	p ⁽²⁾
Not-Aus Drehmoment ⁽³⁾	Emergency stop torque ⁽³⁾	T _{2stop}	Nm	22,5	66	180	390	800	3	1
				30	88	240	520	900	4	
				36	80	220	500	900	5	
				26	80	178	340	-	7	
				27	80	190	380	900	8	
				27	80	200	480	-	10	
				33	88	260	500	-	9	
				40	88	240	520	1600	12	2
				36	88	220	500	1400	15	
				40	88	240	520	1600	16	
				40	88	240	520	1600	20	
				36	80	220	500	1400	25	
				40	88	240	520	1600	32	
				36	80	220	500	1400	40	
				27	80	190	380	900	64	3
				40	88	220	520	-	60	
				40	88	240	520	-	80	
				40	88	240	520	-	100	
				36	88	220	500	-	120	
				40	88	240	520	-	160	
36	80	220	500	-	200					
40	88	240	520	-	256					
36	80	220	500	-	320					
27	80	190	380	-	512					

Antriebsdrehzahlen	Input speeds			PLE040	PLE060	PLE080	PLE120	PLE160	i ⁽¹⁾	p ⁽²⁾
Mittlere thermische Antriebsdrehzahl bei T _{2N} und S1 ⁽⁴⁾⁽⁵⁾	Average thermal input speed at T _{2N} and S1 ⁽⁴⁾⁽⁵⁾	n _{1N}	min ⁻¹	5000	4500	4000 ⁽⁶⁾	3400 ⁽⁶⁾	1350 ⁽⁶⁾	3	1
				5000	4500	3900 ⁽⁶⁾	3500 ⁽⁶⁾	1450 ⁽⁶⁾	4	
				5000	4500	4000 ⁽⁶⁾	3500 ⁽⁶⁾	1700 ⁽⁶⁾	5	
				5000	4500	4000	3500	-	7	
				5000	4500	4000	3500	2200 ⁽⁶⁾	8	
				5000	4500	4000	3500	-	10	
				5000	4500	4000 ⁽⁶⁾	3500 ⁽⁶⁾	-	9	
				5000	4500	4000 ⁽⁶⁾	3500 ⁽⁶⁾	1600 ⁽⁶⁾	12	2
				5000	4500	4000	3500 ⁽⁶⁾	1900 ⁽⁶⁾	15	
				5000	4500	4000	3500 ⁽⁶⁾	1800 ⁽⁶⁾	16	
				5000	4500	4000	3500	2100 ⁽⁶⁾	20	
				5000	4500	4000	3500	2400 ⁽⁶⁾	25	
				5000	4500	4000	3500	2700 ⁽⁶⁾	32	
				5000	4500	4000	3500	3000 ⁽⁶⁾	40	
				5000	4500	4000	3500	3000	64	3
				5000	4500	4000	3500	-	60	
				5000	4500	4000	3500	-	80	
				5000	4500	4000	3500	-	100	
				5000	4500	4000	3500	-	120	
				5000	4500	4000	3500	-	160	
5000	4500	4000	3500	-	200					
5000	4500	4000	3500	-	256					
5000	4500	4000	3500	-	320					
5000	4500	4000	3500	-	512					
Max. mechanische Antriebsdrehzahl ⁽⁴⁾	Max. mechanical input speed ⁽⁴⁾	n _{1Limit}	min ⁻¹	18000	13000	7000	6500	6500		

⁽¹⁾ Übersetzungen (i=n₁/n₂)

⁽²⁾ Anzahl Getriebestufen

⁽³⁾ 1000-mal zulässig

⁽⁴⁾ Applikationsspezifische Auslegung der Drehzahlen mit NCP – www.neugart.com

⁽⁵⁾ Definition siehe Seite 166

⁽⁶⁾ Mittlere thermische Antriebsdrehzahl bei 50% T_{2N} und S1

⁽¹⁾ Ratios (i=n₁/n₂)

⁽²⁾ Number of stages

⁽³⁾ Permitted 1000 times

⁽⁴⁾ Application-specific speed configurations with NCP – www.neugart.com

⁽⁵⁾ See page 167 for the definition

⁽⁶⁾ Average thermal input speed at 50% T_{2N} and S1

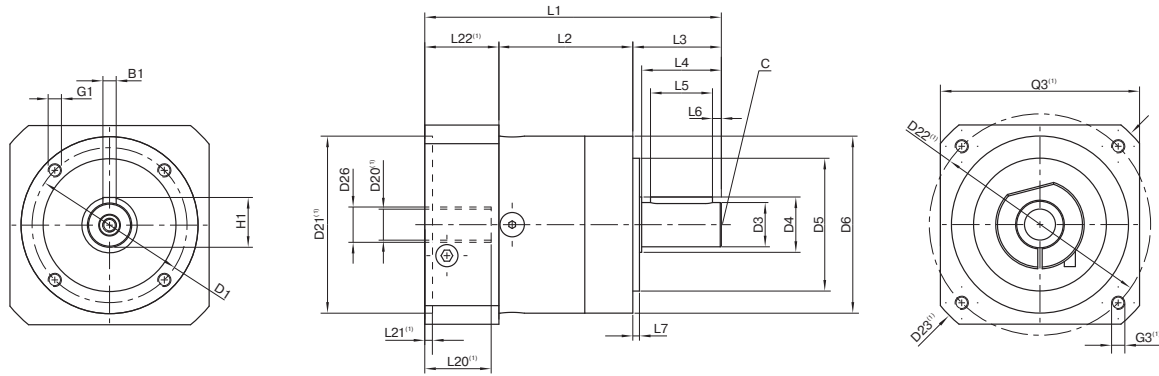

Darstellung entspricht einem PLE060 / 1-stufig / Abtriebswelle mit Passfeder / 11 mm Spannsystem / Motoranpassung – einteilig / B5 Flanschtyp Motor
 Drawing corresponds to a PLE060 / 1-stage / output shaft with feather key / 11 mm clamping system / motor adaptation – one part / B5 flange type motor

⁽¹⁾ Die Maße variieren je nach Motor-/Getriebeflansch. Die motorspezifischen Antriebsflansch-Geometrien können im Tec Data Finder für jeden Motor gezielt abgerufen werden - www.neugart.com
⁽¹⁾ The dimensions vary with the motor/gearbox flange. The input flange dimensions can be retrieved for each specific motor in Tec Data Finder at www.neugart.com

Geometrie ⁽²⁾	Geometry ⁽²⁾			PLE040	PLE060	PLE080	PLE120	PLE160	p ⁽³⁾	Code
Lochkreisdurchmesser Abtrieb	Pitch circle diameter output	D1		34	52	70	100	145		
Wellendurchmesser Abtrieb	Shaft diameter output	D3	h7	10	14	20	25	40		
Wellenansatz Abtrieb	Shaft collar output	D4		12	17	25	35	55		
Zentrierbund Ø Abtrieb	Centering diameter output	D5	h7	26	40	60	80	130		
Gehäusedurchmesser	Housing diameter	D6		40	60	80	115	160		
Anschraubgewinde x Tiefe	Mounting thread x depth	G1	4x	M4x6	M5x8	M6x10	M10x16	M12x20		
Min. Gesamtlänge	Min. total length	L1		88,5	106	133,5	176,5	255,5	1	
				106,5	118,5	150,5	204	305	2	
				114	131	168,5	231,5	-	3	
Gehäuselänge	Housing length	L2		39	47	60	74	104	1	
				51,5	59,5	78	102	153,5	2	
				64,5	72	95,5	129,5	-	3	
Wellenlänge Abtrieb	Shaft length output	L3		26	35	40	55	87		
Zentrierbundtiefe Abtrieb	Centering depth output	L7		2	3	3	4	5		
Durchmesser Motorwelle j6/k6	Motor shaft diameter j6/k6	D20		Weitere Informationen auf Seite 163/164 More information on page 163/164						
Ø Spannsystem am Antrieb	Clamping system diameter input	D26		Weitere Informationen auf Seite 163/164 More information on page 163/164						
Abtriebswelle mit Passfeder (DIN 6885-1)	Output shaft with feather key (DIN 6885-1)			A 3x3x18	A 5x5x25	A 6x6x28	A 8x7x40	A 12x8x65		A
Passfederbreite (DIN 6885-1)	Feather key width (DIN 6885-1)	B1		3	5	6	8	12		
Wellenhöhe inklusive Passfeder (DIN 6885-1)	Shaft height including feather key (DIN 6885-1)	H1		11,2	16	22,5	28	43		
Wellenlänge bis Bund	Shaft length from shoulder	L4		23	30	36	50	80		
Passfederlänge	Feather key length	L5		18	25	28	40	65		
Abstand vom Wellenende	Distance from shaft end	L6		2,5	2,5	4	5	8		
Zentrierbohrung (DIN 332, Form DR)	Center hole (DIN 332, type DR)	C		M3x9	M5x12,5	M6x16	M10x22	M16x36		
Glatte Abtriebswelle	Smooth output shaft									B
Wellenlänge bis Bund	Shaft length from shoulder	L4		23	30	36	50	80		

⁽²⁾ Maße in mm
⁽³⁾ Anzahl Getriebestufen

⁽²⁾ Dimensions in mm
⁽³⁾ Number of stages